



JIMS CATALOG • ISSUE 25



MILWAUKEE-EIGHT®  
JIMS® FORCEFLOW

C.N.C. MANUFACTURING  
AND ENGINEERING  
SINCE 1967





## NEW PRODUCT SECTION

JIMS® FORCEFLOW.....	I
MILWAUKEE EIGHT® TOOLS.....	II-IV
DAMAGE CONTROL ENGINE FAILURE DETECTION SYSTEM.....	V
ELECTRICAL.....	VI-VII
VALVETRAIN.....	VIII-IX
TRANSMISSION.....	X-XI
PRIMARY.....	XII-XIV
FRAME & FORK.....	XV-XVI
WHEEL & JIMS HAT.....	XVII-XVIII
BRAKE.....	XIX
LIFT & STAND.....	XX-XXI
HARDWARE.....	XXII
JIMS BLACK HANDCRAFTED & WELDED COVERS.....	XXIII
INDIAN® & VICTORY.....	XXIV



**HIRO KOISO'S  
LANDSPEED  
135" RACE ENGINE**

*#MyJIMS Instagram Image*

⚠️ DANGER

DO NOT OPERATE

HIRO



# JIMS® NEW PRODUCTS FORCEFLOW®

## NEW FOR MILWAUKEE EIGHT



\*Twin Cam Application



### THE JIMS FORCEFLOW® CYLINDER HEAD COOLER

This smooth, streamline design will keep your V-Twin running cooler on those hot summer days in stop and go traffic. The JIMS® R&D department has come up with a serious way to drop your head temperature by as much as 100 degrees. Although this mounts in the horn location, JIMS has relocated a horn inside the fan housing. The cooling fan can be controlled manually or it can be regulated by a thermostat that monitors head temperature and activates the fan when engine temperature rises. This kit is highly recommended for performance motors to help extend engine life. Complete kit includes high powered fan, housing, thermostat, horn, hardware and all wiring, along with detailed instructions.

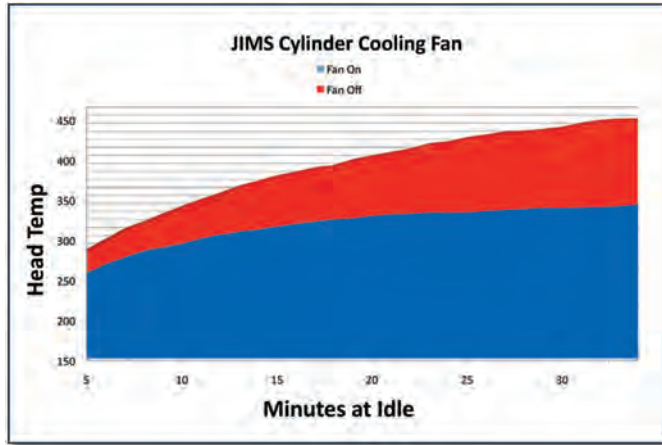

It's common knowledge that heat is one of an engine's worst enemies. In developing the JIMS cylinder head cooler, JIMS had to sacrifice a few motors for the cause. We tested worst case scenarios by letting engines idle in the sun for over a half hour each while recording cylinder head temperatures minute by minute. The graph above represents the average temperature reduction when using JIMS cylinder head cooler.



\*Milwaukee Eight Application



**NEW**

### MILWAUKEE EIGHT

#### USE ON 2017-PRESENT MILWAUKEE EIGHT TOURING.

(Kit installs from horn location)

- No. 5468 - Black Cylinder Head Fan kit.
- No. 5469 - Chrome Cylinder Head Fan kit.

### USE ON 1999-2016 TWIN CAM TOURING MODELS & OTHER MODELS WITH SOME FABRICATION.

(Kit installs from horn location & is supported by the center case bolt location.)

- No. 5462 - Chrome Cylinder Head Fan kit.
- No. 5400 - Polished Cylinder Head Fan kit.
- No. 5401 - Black Cylinder Head Fan kit.
- No. 5402 - Silver Cylinder Head Fan kit.
- No. 5447 - JIMS Engine Hardware Mounting kit.



### JIMS® FORCEFLOW CENTER CASE BOLT FOR CVO™ 110 AND SE 120R RACE ENGINES

No. 5457 - Stud Assembly Kit

# JIMS® NEW PRODUCTS MILWAUKEE EIGHT®



## **NEW** WRIST PIN REMOVER ADAPTER

*(Use with existing JIMS wrist pin remover tool No.1276 - purchased separately)*

The new Milwaukee Eight® engine uses different wrist pins compared to other Harley-Davidson® engines. This tool quickly and easily removes the wrist pins in these new engines. To reduce cost and save toolbox space, this adapter is used with our existing wrist pin tool No.1276.

No. 5805 - Use on the new Milwaukee Eight® engine.

## **CAMSHAFT NEEDLE BEARING REMOVER AND INSTALLER** **NEW**

The Milwaukee Eight® engine returns to the single camshaft design, which requires a new tool for correct and accurate replacement of the camshaft inner needle bearing. Compared to the OEM tool, this remover uses the proven "JIMS style" remover collet as well as JIMS fine threaded installation driver. We've incorporated a new removal hole that works as a window to let you see what you are doing while using the tool. The JIMS tool holds tighter tolerances, which allows for a more precise installation depth.

No. 5806 - Use on the new Milwaukee Eight® engine.



## **NEW** MILWAUKEE EIGHT® VALVE SPRING COLLAR

*(Use with existing JIMS valve spring compressor tool No.96600-36B - purchased separately)*

The smaller multiple valves of the Milwaukee Eight® engine require a different valve spring collar for disassembly and assembly. Rather than come up with an entirely new tool for the job, JIMS has developed an adapter collar that allows our existing valve spring compressor (No.96600-36B) to get both jobs done. The usual advantages of lower cost and less space required in the toolbox add to this tool's function.

No. 5808 - Use on the new Milwaukee Eight® engine.



## **NEW** LEFT MAIN SEAL INSTALLER

Less than perfect installation of the left crankshaft oil seal can result in unwanted oil transfer between the engine and primary drive. The JIMS left main bearing oil seal installer not only assists with perfect installation (which includes bottoming out when the seal is properly installed) but it has the added advantage of allowing the alternator stator to remain in place during the operation.

No. 5810 - Use on the new Milwaukee Eight® engine.



SEE ON  
YouTube

## **NEW** LEFT MAIN SEAL REMOVER

The Milwaukee Eight has a new crankshaft oil seal that is difficult to remove without potentially damaging the crankcase bore. This new unique and exclusive JIMS tool is designed to do the job right, with no chance of damage to the case. Simply insert the removal fingers over the engine output shaft, and then slide the lock collar over the fingers. Once assembled, you can easily remove the seal square to the bore by simply turning a wrench. *(See page XIII for Twin Cam Application)*

No. 5830 - Use on the new Milwaukee Eight® engine.



SEE ON  
YouTube



# JIMS® NEW PRODUCTS MILWAUKEE EIGHT®



## **BALANCER SCISSOR GEAR ALIGNMENT SCREW**

This tool holds the two halves of the spring loaded scissor balancer gear in alignment before removal for easy installation. No more fumbling with screwdrivers while trying to align the gear in place. This screw is brightly colored to remind the technician to remove it before sealing the engine case.

No. 5811 - Use on the new Milwaukee Eight® engine.



SEE ON  
YouTube



## **CYLINDER HOLD DOWN NUTS**

Cylinder hold down nuts are an effective way to keep the cylinders in place when the heads are removed from the engine. This is particularly useful when installing the second cylinder over the piston and rings after the first cylinder has been installed. It is also advantageous to have the cylinders secured when rotating the crankshaft for other work. In any case, even a slight rocking of the cylinder can damage the base gasket or cause a cylinder to lift entirely off the cases. These new JIMS Hold Down Nuts have different threads at each end. One end fits Twin Cam models, while the other end works with Milwaukee Eight® engines.

No. 5809 - Use on the new Milwaukee Eight® engine and Twin Cam, sold 2 per kit.

SEE ON  
YouTube



## **MIGHTY BITE FOR THE MILWAUKEE EIGHT®**

The "Mighty Bite", originally designed by JIMS for Twin Cam models, is designed to lock the crankshaft when doing service work. The new Milwaukee Eight® has a different crank position sensor location and requires a different profile to lock the flywheel. This tool specifically locates and locks the flywheel in the new Milwaukee Eight® engine and has an added O-ring to prevent oil seepage.

No. 5823 - Use on the new Milwaukee Eight® engine.



## **COUNTERSHAFT 1ST SCISSOR GEAR ALIGNMENT TOOL**

This tool is essential for installation of the countershaft 1st scissor gear in Cruise Drive transmissions. It is installed before the scissor gear is removed to maintain alignment of the gear halves under spring pressure. This ensures that the scissor gear teeth mesh correctly with the mainshaft 1st gear.

No. 5816 - Use on Cruise Drive transmissions utilizing a scissor first gear.



## **MILWAUKEE EIGHT® AND TWIN CAM HEAD HOLDER**

Different spark plug holes in the Milwaukee Eight® heads call for a different head holder, and we have it. The proven system of anchoring the head in a vice is now available from JIMS for this new engine series. Our new tool is two sided, one side threaded for Twin Cam Heads, and the other threaded for the new Milwaukee Eight®.

No. 5828 - Use on the new Milwaukee Eight® as well as all Twin Cam Heads.





# JIMS® NEW PRODUCTS MILWAUKEE EIGHT®



## **NEW MILWAUKEE EIGHT® ENGINE STAND**

SEE ON  
YouTube

What was the first thing JIMS did when we took delivery of our new Milwaukee Eight® test bike? We removed the engine to take a peek inside, of course. Instantly we realized a new engine stand was in order! JIMS engine stands are built from .125" steel and powder coated JIMS blue. This stand is a must if you are going to do any powertrain work on the new bikes!  
No. 5826 - Use on the new Milwaukee Eight® Touring engine.

## **NEW ALTERNATOR ROTOR REMOVER AND INSTALLER**

Removing or installing the high output alternator rotor on the Milwaukee Eight® requires a unique tool, and trust us those magnets don't budge easily! At JIMS we understand that using pry bars or striking with a hammer can not only damage the rotor housing, but the magnets as well. This tool easily removes the rotor while protecting the rare earth magnets within it.

No. 5812 - Use on the new Milwaukee Eight® engine.



SEE ON  
YouTube

SEE ON  
YouTube



## **NEW MAIN BEARING REMOVER & INSTALLER**

The Milwaukee Eight® engine uses a completely unique engine case main bearing. With this in mind, JIMS is proud to introduce a main bearing remover and installer designed just for the Milwaukee Eight®. High levels of precision and accuracy are necessary, so only the best tools can be trusted. Our tool not only removes the left and right main bearing without damaging the case, it also provides correct alignment and depth during installation.

No. 5813 - Use on the new Milwaukee Eight® engine.

## **NEW TORQUE PLATES**

Aluminum cylinders cannot be accurately honed and measured without the use of torque plates. The JIMS® Torque Plate kit for use on Milwaukee Eight® cylinders will simulate operating stress conditions when boring or honing the cylinders. These plates adapt easily to conventional boring bars or a Sunnen type honing machine. They are laser etched with the torque sequence for ease of use, and do not require removal of ring dowels.

No. 5829 - Use on the new Milwaukee Eight® engine.





# JIMS® NEW PRODUCTS DAMAGE CONTROL

**SAVE YOUR  
ENGINE**

## DAMAGE CONTROL ENGINE FAILURE DETECTION SYSTEM

JIMS engine failure detection system provides an early warning of catastrophic engine failure. Using state of the art technology, our new system monitors the presence of ferrous metal debris in the engine oil through a sensor in the drain plug. When particulates in the oil reach a level that could indicate impending trouble, the LED warning light in the handlebar clamp illuminates. Although not capable of predicting every mechanical failure, our JIMS device, made in the

USA, provides additional protection against engine repairs that could cost 50 times as much as the device itself. An easy to install wiring harness is included, and no cutting or splicing is required. Available for both 1 1/4" and 1" handlebars, in black or chrome. *For more details see No. 2051-IS instructions.*

*Use on Milwaukee Eight® 2017-present Touring Models, 1993-2016 Touring Models and 1991-2016 Dyna® Models.*

### 1" Handlebar

No. 2053 - Black DC Kit

No. 2054 - Chrome DC Kit

### 1 1/4" Handlebar

No. 2051 - Black DC Kit

No. 2052 - Chrome DC Kit

**AN EXAMPLE OF A TEST  
DAMAGE CONTROL DRAIN  
PLUG THAT PREDICTED AN  
ENGINE FAILURE!**



**BLACK  
ANODIZE**

**CHROME**

### PARTS AVAILABLE SEPARATELY

QTY	DESCRIPTION	PART NO.
1	TOP CLAMP 1-1/4" BLK	2051-1
1	BOTTOM CLAMP 1-1/4" BLK	2051-2
1	DRAIN PLUG ASSEMBLY	2059
1	WIRE HARNESS	2058
4	SOC CAP SCREW #4-40X3/8	2057
1	TOP CLAMP 1" BLK	2053-1
1	BOTTOM CLAMP 1" BLK	2053-2
1	TOP CLAMP 1 1/4" CHR	2052-1
1	BOTTOM CLAMP 1 1/4" CHR	2052-2
1	TOP CLAMP 1" CHR	2054-1
1	BOTTOM CLAMP 1" CHR	2054-2
1	O-RING, DRAIN PLUG	2059-6
1	INSTRUCTION SHEET	2051-IS

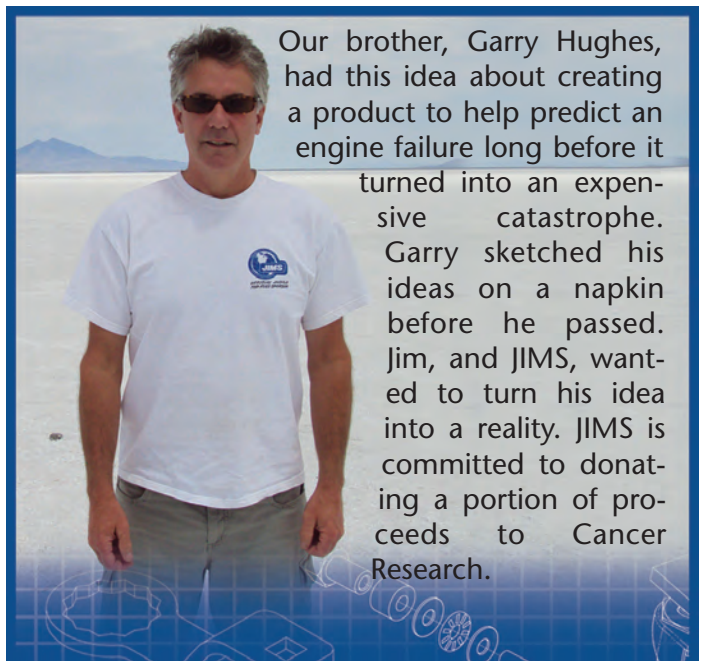

Our brother, Garry Hughes, had this idea about creating a product to help predict an engine failure long before it turned into an expensive catastrophe. Garry sketched his ideas on a napkin before he passed. Jim, and JIMS, wanted to turn his idea into a reality. JIMS is committed to donating a portion of proceeds to Cancer Research.





## ONBOARD DIAGNOSTIC VOLTMETER

Like all modern motor vehicles, Harley-Davidson® motorcycles are much more dependent upon their electrical charging systems. Electronic fuel injection systems with high pressure fuel pumps, audio, GPS / Navigation and more powerful lights that are on whenever the motorcycle is operating, add significantly to electrical demands. Charging system failure can be more than just an inconvenience, so it makes sense to take preventative measures. JIMS new Onboard Diagnostic Voltmeter attaches easily to the battery and can be quickly viewed to spot potential charging system and battery problems.

No. 5500 – For all 6 or 12 volt battery and charging systems.

## BATTERY LIFTER

Even sealed and gel cell batteries can leak harmful and corrosive chemicals that can cause damage to skin and clothing. JIMS new Battery Lifter is modeled after the larger tools made for automotive batteries but is properly sized to fit a variety of motorcycle batteries. Our concern for safety goes beyond just riding the motorcycles.

No. 5501 – For all H-D® batteries where lifting straight up is difficult to impossible.



## NEW REMOTE FUEL SUPPLY FOR FUEL INJECTED MOTORCYCLES

Fuel tank removal is often required for service and diagnostics. Additionally, the tank may need to be off while the engine is running, especially for testing purposes. This presents a problem for fuel injection systems that have the fuel pump in the tank. To deal with this, JIMS now offers a complete “plug and play” solution: a compact, remote billet fuel tank that accepts air pressure from an air compressor to supply correctly pressurized fuel to the EFI system. Unlike the gravity feed tanks used with carburetor systems, this EFI tank solution is designed to safely handle the required air pressure. Once pressurized, the tank is completely mobile and can run a motorcycle (canister does not need to be connected to air supply). Our system includes all necessary OEM fittings to plug directly into the fuel rail, plus valve and air pressure gauge. The tank can be easily hung from the handlebar or attached to a wall, workbench, or rollaway tool chest.

No. 5530 – Use on all Delphi Fuel Injected Harley-Davidson® models except V-Rod®.

SEE ON  
YouTube



## IGNITION SWITCH ALIGNMENT KEY FOR 2014 - PRESENT TOURING MODELS

The professional technician needs fast and accurate alignment of the ignition switch. Fiddling with screwdrivers and coat hangers does not cut it! Our alignment tool is the perfect solution; correct alignment is quickly and easily achieved. This tool is for 2014 and later touring models and is based on our proven design for earlier models. Legendary JIMS quality allows us to give a lifetime guarantee on this made in the USA tool. For more details see No. 943-IS instructions.

No. 944 - Use on 2014-present Touring and Trike Models that have an H-D No.71400013A ignition.



## NEEDLE SHARP MULTIMETER PROBE KIT

Today's wiring harnesses and fairings are filled with hundreds of multiple gauge wires and connectors. This new kit has an assortment of needle sharp probes for precise and non-damaging diagnostic work. Probes can be used with standard 4 mm banana jack connections common with most multimeters. The selection includes: Straight, 45°, and 90° probes (with 2 probe diameters) for hard to reach terminals as well as standard alligator clips. Similar kits on the market cost twice as much! All probes are fully insulated with 30v protection.

No. 737 - 17 Piece needle sharp probe kit



## TAPPET POSITION HOLDING TOOL

Expert technicians know that keeping the same parts operating in their original position and direction is a good idea. This is especially true with the tappets in Harley-Davidson® engines.

Whenever the tappets are removed, in the case of a camshaft change or complete tear down, our new Tappet Position Holding Tool allows the tappets and anti rotation pins to be safely and accurately stored for proper reinstallation. Tappet locations are clearly referenced on the tool, which also serves to protect the tappets from damage when removed from the engine.

No. 5504 - For all Twin Cam engines 1999 to present, 2000 to present XL and Buell® (except 1125R), 2017-present Milwaukee Eight® engine.



## **JIMS 4340 CHROMOLY STEEL PUSHRODS AND SOLID ADJUSTABLE TAPPET KIT FOR SHOVELHEAD**

**NEW**

Despite advancements in hydraulic lifters, solids are still the way to go for maximum power. Most engine builders agree that solid lifters can withstand more aggressive cam profiles and higher RPM. Just because your engine is an older Shovelhead design doesn't mean you have to settle for anything less than the best. JIMS® is proud to now offer a top quality 4340 chromoly steel pushrod and adjustable solid lifter kit for Shovelhead Engines.

No. 5525 – Use on 1966-1984 Shovelhead engines.



## **POWERGLIDE™ STEADY ROLL TAPPETS**

It is no secret to us at JIMS® (and to top engine builders) that performance V-Twin engines require more valve lift than stock designs. This increases the load on the tappet roller, which can lead to failure. Tappet roller failure is a catastrophic and expensive failure. Broken needle bearings allow the tappet roller to deform, causing cam lobe damage. Pieces of the hard bearings, as well as debris from the cam can easily contaminate other parts, such as cam plates, bearings, oil pumps, and other tappets ultimately resulting in a complete rebuild. To remedy this, we have replaced the needle bearings with a special bronze alloy bushing, resulting in increased reliability and longevity.

No longer do you need to worry about needle bearings and debris damaging the engine in the event of a failure. In addition to this, JIMS has invested in new machinery that controls the hydraulic unit fitment tolerance within .00015". This new failsafe design means that even if the bushing wears out, it will be retained in the tappet assembly. The new Powerglide Steady Roll Tappets are available for use on all Milwaukee Eights®, Twin Cams, Sportster 2000-present, and Buell® 2000-present (except 1125R.) Also, on 1984-present EVO, 1986-1990 XL & 1987-1990 Buell®. For more details see No. 1827-IS instructions.

**Milwaukee Eight** - Use on 2017-present Milwaukee Eight® engine, both Touring & Softail.

**Twin Cam** - Use on 1999-2016 Twin Cam, 2000-present Sportster & Buell®.

No. 1827 - (.8420" O.D.)

No. 1828 - (+.002" O.D.)

No. 1829 - (+.010" O.D.)

**Evolution** - Use on 1984-present Evo, 1986-1990 XL & 1987-1990 Buell®.

No. 1824 - (.8425" O.D.)

No. 1825 - (+.002" O.D.)

No. 1826 - (+.005" O.D.)

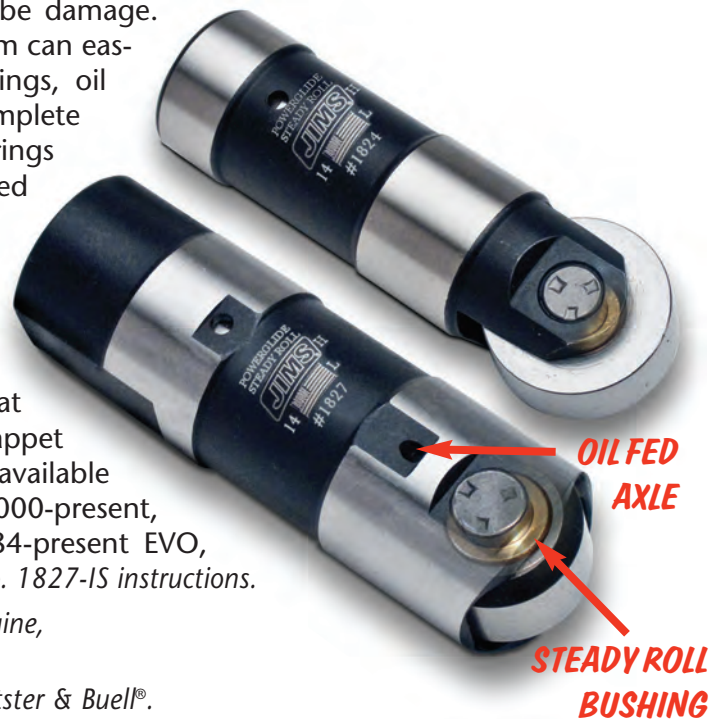

**STEADY ROLL**



**NEEDLE BEARING**



## **TAPPET ADJUSTMENT TOOL**

Designed and submitted by Hiro Koiso (a hands-on technician and JIMS sponsored Bonneville record holder in numerous classes); this patent pending hand tool simplifies the way to verify proper tappet adjustment. After adjusting the tappet, simply insert the tip of this tool under the hydraulic unit retaining clip, above the pushrod seat. Similar to a "Go No-Go Gauge", if the tip doesn't fit between the clip and the pushrod seat OR if there is up and down endplay, the tappet is out of adjustment. Only when the tip fits nicely with no endplay is the tappet properly adjusted. *For more details see No. 746-IS instructions.*

No. 746 - Use on most hydraulic tappets, OEM and aftermarket, for Milwaukee Eight®, Twin Cam or Evo. (Does not work on Solids, JIMS Hydrosolids or other limited travel tappets.)



## **NEW 110" PISTON PIN CLIP REMOVER & INSTALLER**

Incorrect piston pin clip removal can damage the piston, and incorrect installation can damage the clip. Damaged clips can come out during engine operation, causing catastrophic failure. This tool is designed exclusively for the Screamin' Eagle® 110" engine to ensure proper pin clip removal and installation.

No. 5814 - Use on Screamin' Eagle® 110" engines 2007-2016.

SEE ON  
YouTube

## **NEW VACUUM TAPPET "PUMP UP" TOOL**

Our popular and effective bleed technology that is found in the JIMS brake bleeding tool has now been applied to hydraulic lifters. A special jar, designed for vacuum, holds up to four hydraulic lifters in a convenient tray. Once vacuum is applied, bubbles can be seen escaping from the lifters until they are completely bled. Lifters are now ready to install. No more abuse of the starting system to pump up the lifters, and no risk of damage to the valve train by running the engine, even at low RPM, when lifters have not been fully bled.

No. 5532 - Use on Milwaukee Eight®, Twin Cam® and Evo Tappets.

(Tool can be used for many other tappets similar in size and diameter.)



# JIMS® NEW PRODUCTS TRANSMISSION

SEE ON  
YouTube



## NEW SHIFTER MECHANISM SLEEVE REMOVER & INSTALLER

This is one of Hiro's time savers for removing and installing the shifter mechanism sleeve in Cruise Drive Big Twin transmissions. With this new tool, the sleeve (bushing) can be removed and installed correctly without disassembling the transmission, saving hours of labor! This tool will pay for itself in one use!

No. 5517 – Use on 2006 Dyna® and all 2007-present Big Twin with 6-speed Cruise Drive Transmission.



### PARTS AVAILABLE SEPARATELY

NO.	QTY.	DESCRIPTION	PART NO.
1	1	DRIVER, SHIFTER BUSHING	5517-1
2	1	GUIDE, INSTALLER, SHIFTER BUSHING	5517-2
3	1	GUIDE, REMOVER, SHIFTER BUSHING	5517-3
4	1	INSTRUCTION SHEET	5517-IS

## CRUISE DRIVE VISE STAND

To assist in the assembly of the transmission gears and shafts, JIMS has developed the Cruise Drive Vise Stand. No more fumbling with parts on the bench or clamping in a vise with soft jaws. This new tool holds the shafts in perfect alignment while protecting them from damage. Faster, easier, and safer assembly is now possible.

No. 2267 - For 2006 to present Dyna and 2007 to present Big Twins.



## 5 SPEED MAIN CASE SEAL INTALLER TOOL

We now offer a new version of our Cruise Drive 6 speed main-shaft seal tool to fit the 5 speed transmissions. Like its Cruise Drive counterpart, it ensures correct alignment, seal protection, and depth when installing the seal.

No. 2268 - For 1985–2006 Five Speed Big Twin and aftermarket 6 speeds.

## CLUTCH SPRING COMPRESSOR ADAPTOR

Thanks to Rob Curtis, we now have an adapter for our No. 38515-90 clutch spring compressor that makes it possible to use this tool for a similar application on Victory® motorcycles. For those who already own our No. 38515-90 clutch spring compressor, this avoids having to purchase another complete tool. Either way, it is a simple and necessary addition to your toolbox if you plan to work on Victory® motorcycles.

No. 5804 – Use on all Victory® models 2001-present with diaphragm clutch spring.





# JIMS® NEW PRODUCTS TRANSMISSION

## 5 AND 6-SPEED COUNTERSHAFT BEARING REMOVER & INSTALLER TOOL

This new JIMS exclusive tool will install or remove the closed end countershaft bearing on all 5-Speed or 6-Speed Cruise Drive transmissions without using a press or tapping it in with a transmission shaft. This is a precision hand tool designed to install the bearing square and to the proper depth, the JIMS way. *For more details see No. 739-IS instructions.*

No. 739 - Use on all H-D® Cruise Drive 6-Speeds and 1980-2006 5-Speeds - including aftermarket 6-speeds.

### PARTS AVAILABLE SEPARATELY

NO.	QTY.	DESCRIPTION	PART NO.
1	1	PULLER BAR	739-1
2	1	DRIVER, CRUISE DRIVE	739-2
3	1	DRIVER, 5 SPEED	739-3
4	1	STOP COLLAR	739-4
5	1	TOOL, SCREW	1024
6	1	SPUD	2190
7	1	BEARING	2010
	1	O-RING	2310
	1	INSTRUCTION SHEET	739-IS

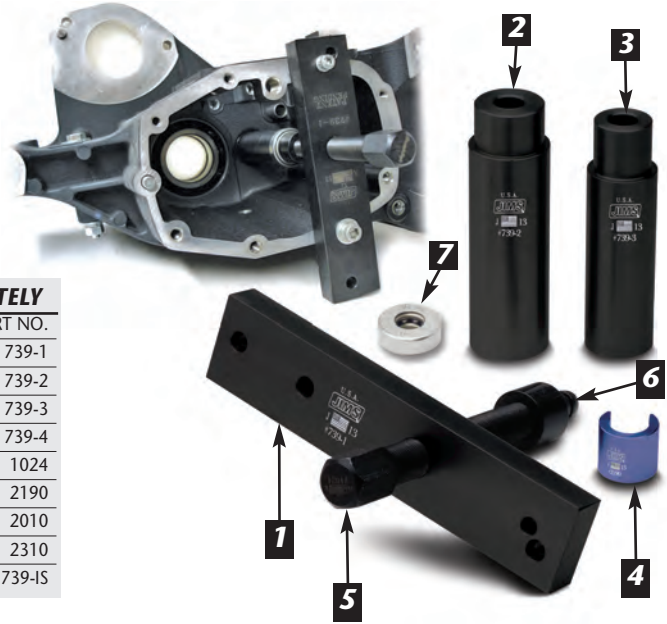

## JIMS CRUISE DRIVE WIDE BEARING TRAP DOOR AND SHIFT FORK SHAFTS UPGRADE KIT

This new JIMS Cruise Drive upgrade kit was designed to give your transmission positive shifting and shaft centerline integrity to handle today's performance powertrains. The upgraded 6061 precision-machined aluminum trap door holds transmission shaft centerlines to within .0005" and incorporates wider, heavy duty bearings. These bearings are retained with beveled retaining rings to minimize bearing end play. Included with the kit are two solid, true centerline, rigid, high strength shift fork shafts that replace the OEM hollow shafts. *For more details see No. 2336-IS instructions.*

No. 2336 - Black, Use on all H-D Cruise Drive transmissions to present.

No. 2340 - Silver, Use on all H-D Cruise Drive transmissions to present.



### PARTS AVAILABLE SEPARATELY

NO.	QTY.	DESCRIPTION	PART NO.
1	1	TRAP DOOR, BLACK	2336-1
1	1	TRAP DOOR, SILVER	2336-2
2	1	SHIFT SHAFT, LONG, CRUISE DRIVE	2336-3
3	1	SHIFT SHAFT, SHORT, CRUISE DRIVE	2336-4
	2	BEARING, TRAP DOOR	8992
	2	RETAINING RING, TRAP DOOR	35087-99
	2	DOWEL PIN	221
	2	DOWEL BUSHING	1486-1828
	1	INSTRUCTION SHEET	2336-IS

## ULTIMATE CLUTCH ADJUSTING TOOL



This year's time saver is our Ultimate Clutch Adjusting Tool. This tool allows the technician to quickly and accurately tighten the clutch adjusting screw jam nut without having the screw change position on 1985 and later Big Twin models. No more guessing or making multiple attempts to lock the nut and adjuster screw in the proper place. This JIMS®

tool includes the proper hex key "Allen" wrench for Harley-Davidson® motorcycles which conveniently stores in the tool handle.

No. 5502 – For all Big Twins 1985 to present with cable actuated clutch.

## INNER PRIMARY BEARING AND SEAL REMOVAL / INSTALLATION KIT

When it comes to servicing the inner primary bearing and seal, do it the JIMS way. This American made tool has a lifetime warranty and drives the bearing and seal perpendicular to the case without an arbor press. JIMS has been manufacturing the No. 967 Inner Primary Bearing and Seal Removal / Installation kit for over 6 years. We have taken its proven design and added on 2006 Dyna® and all 2007 to present Big Twin models. This tool easily removes and installs the inner primary roller bearing and installs the seal and bearing to factory specified depths. Now you can purchase kit No. 729 to work on all Big Twins from 1985 to present; or if you have a JIMS No. 967 kit, you can upgrade it by purchasing the two late model drivers. For more details see No. 729-IS instructions.

PARTS AVAILABLE SEPARATELY			
NO.	QTY.	DESCRIPTION	PART NO.
1	1	SEAL INSTALLER	967-1
2	1	RECEIVER CUP EARLY	967-2
3	1	BEARING REMOVER EARLY	967-3
4	1	BEARING REMOVER LATE	967-4
5	1	BEARING REMOVER LATE	967-5
6	1	HEX BOLT	1211
7	2	WASHER	2038
8	1	BEARING	2010
9	1	NUT	2136
10	1	INSTRUCTION SHEET	729-IS

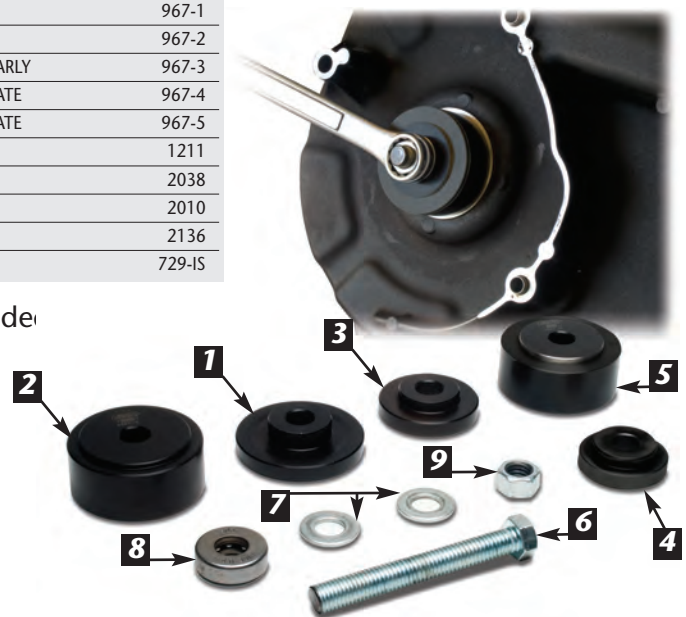

No. 729 - Use on all 1985-present Big Twin Models.

## NEW SHIFT PEDAL SHAFT BUSHING TOOL

The gear shift foot lever / pedal bushings on 5 & 6 speed Harley-Davidson® touring models often have a typical service life of 20,000 miles or less. Bushing wear results in an annoying rattle from the loose shifter, the linkage parts and accelerated wear of all related parts. JIMS® has tackled this problem with another one of Hiro's new time saving tools that easily removes both worn bushings at the same time and quickly installs the new bushings to the proper location without removing the inner primary! Using this tool, a technician can remove and install the bushings in approximately 20 minutes.

No. 5518 – Use on all 1985-2016 Big Twin FLT. (Rubber Mount Touring Models)



PARTS AVAILABLE SEPARATELY			
NO.	QTY.	DESCRIPTION	PART NO.
1	1	REMOVER, SHIFTER SHAFT BUSHING	5518-1
2	1	INSTALLER NUT, SHIFTER SHAFT BUSHING	5518-2
3	1	INSTALLER, SHIFTER SHAFT BUSHING	5518-3
4	1	SCREW, 5/16-18X4" BHCS, FULL THREADS	5518-4
5	1	INSTRUCTION SHEET	5518-IS





## COMPENSATING SPROCKET LOCK KIT

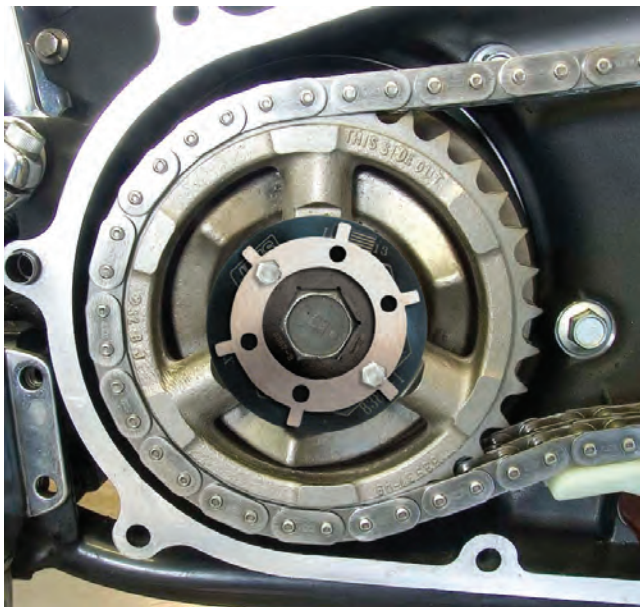

Peace of mind is key when it comes to building a high performance powertrain. The Compensating Sprocket Lock Kit is now ready and available for select Harley-Davidson motorcycles. This system positively secures the compensating sprocket so it cannot come loose. Rubber mounted engines may insulate the rider and frame mounted components from vibration, but the entire powertrain, including the compensating sprocket, is still at risk from fasteners coming loose due to shaking. Additionally, today's larger and more powerful engines can cause a lesser fastening system to come loose from large power pulses combined with the back and forth motion from getting on and off the throttle. Along with drive line security, the JIMS Compensating Sprocket Lock Kit keeps the alternator rotor in place to prevent damage to the charging system as well. This is not only a race engine item, stock bikes will also benefit from this upgrade to increase reliability and safety. For use on 2006 Dyna® and 2007-present Big Twins

with Screamin' Eagle performance compensator. Not for early style compensator with spring cup attached to rotor or 2014 stock compensator. *For more details see No. 8385-IS instructions.*



PARTS AVAILABLE SEPARATELY			
NO.	QTY.	DESCRIPTION	PART NO.
1	1	RETAINER, SHORT COMP LOCK	8387-1
2	1	RETAINER, LONG COMP LOCK	8385-1
3	1	LOCK RING	8387-2
4	1	LOCK TAB	8387-3
5	2	SCREW	8388
6	1	INSTRUCTION SHEET	8385-IS



No. **8387** - Use on 2011 FLH and 08-11 Softail Rocker, No. 40370-08 and 83935-09 and Screamin' Eagle No. 40274-08.

No. **8385** - Use on 2012-2013 OEM compensators No. 83935-09A and Screamin' Eagle No. 40274-08A.



## ENGINE MAIN SEAL REMOVER AND INSTALLER

This specialty tool is designed to remove and install the crankcase main seal while the engine is still in the chassis. The unique design reduces the risk of damage to the crankshaft and crankcase. Manufactured from hardened tool steel, the kit includes adapters required for use on both Twin Cam 88® and Twin Cam 96™ based engines. (See Page II for Milwaukee Eight Application)

No. **775** - Use on 1999-2016 Twin Cam engines.



# JIMS® NEW PRODUCTS PRIMARY

## **NEW LATE MODEL COMPENSATOR BOLT TORX® SOCKET**

Harley-Davidson® recently changed the compensating sprocket retaining fastener to an internal drive, very large Torx® type bolt. The driver / socket for this bolt can be difficult to find and most likely is not in your tool box. Often it can only be purchased in an expensive set. Don't be caught stranded - JIMS® now offers a quality socket / driver for this application priced affordably and sold individually.

No. 5534 – Use on all 2014-present Big Twin models.



SEE ON  
YouTube

## **NEW XL PRIMARY LOCK BAR**

This tool locks the primary drive on XL models to facilitate crankshaft sprocket nut removal and installation, along with clutch service allowing for removal, installation, and accurate torque when tightening the final drive front sprocket/pulley nut.

No. 5520 – Use on 2004-present XL 1200 models.



SEE ON  
YouTube



SEE ON  
YouTube

## **NEW XL SPROCKET NUT SOCKET**

This short socket is designed specifically for XL models to remove, install, and properly tighten the front final drive sprocket/pulley nut. Although the much longer Big Twin socket will fit the nut, the mainshaft on XL models does not extend through for the guidance collar to ensure correct alignment. This shorter socket is easier and safer to handle, providing full contact with the nut.

No. 5516 – Use on all 1991-present Sportster® and Buell® models (except 1125R models).





# JIMS® NEW PRODUCTS FRAME & FORK

## VACUUM FED FORK FILLING TOOL

Changing the fork fluid on models with fairings can be intimidating and take hours. This tool eliminates the need to remove the fairing on all touring bikes to change the fork oil. It's like magic! With this tool it should take about 30 minutes to perform the service compared to 2.2 hours without it. To fill the fork, simply insert the tapered fitting into the drain hole and create a vacuum using a standard Mityvac hand pump. Once you reach approximately 25 lbs. of vacuum pressure, rotate the valve and instantly the vacuum will draw the pre-measured amount of fork fluid into the fork tube. Use on all common damper tube type fork assemblies. This tool is not for use on motorcycles using cartridge type forks or inverted fork assemblies. This tool is designed for use in conjunction with a Mityvac® tool No. 741, which is available separately. *For more details see No. 740-IS instructions.*

No. 740 - Use on all common damper tube type fork assemblies with drain screws. (Not for use on motorcycles using cartridge type forks or inverted fork assemblies.)

No. 741 - Mityvac Hand Vacuum Pump kit. (Sold separately)

PARTS AVAILABLE SEPARATELY			
NO.	QTY	DESCRIPTION	PART NO.
1	1	BASE, FORK OIL TOOL	740-1
3		MAGNET, GRADE N42, 1/2" X 1/8"	740-2
2	1	BOTTLE, MODIFIED, FORK OIL TOOL	740-3
3	1	ADAPTER, BOTTLE	740-4
4	1	3-WAY BALL VALVE	740-5
5	1	RESERVOIR CUP ASSEMBLY	740-6
	1	O-RING 1.75" ID X .139"	740-7
6	1	ELBOW, 1/4"	740-8
7	1	"L" BRACKET, VALVE	740-9
8	1	FILLER TIP, FORK OIL TOOL	740-10
9	1	STRAIGHT HOSE BARB, 1/4 NPT	740-11
	1	U-BOLT, 1/4-20 X 1" THREAD, BLACK	740-12
	2	SCREW, 1/4-20 X 1/2" FHS, BK ALLOY	740-13
	1	CAP, MODIFIED	740-14
	2	NUT, 1/4-20 FLANGE, NYLON	5263
10	1	ELBOW, 1/4 NPT X 1/4" HOSE BARB	740-15
11	1	1/4" HOSE, 22"	1994-1
12	1	1/4 HOSE, 12"	1994-2
	1	INSTRUCTION SHEET	740-IS

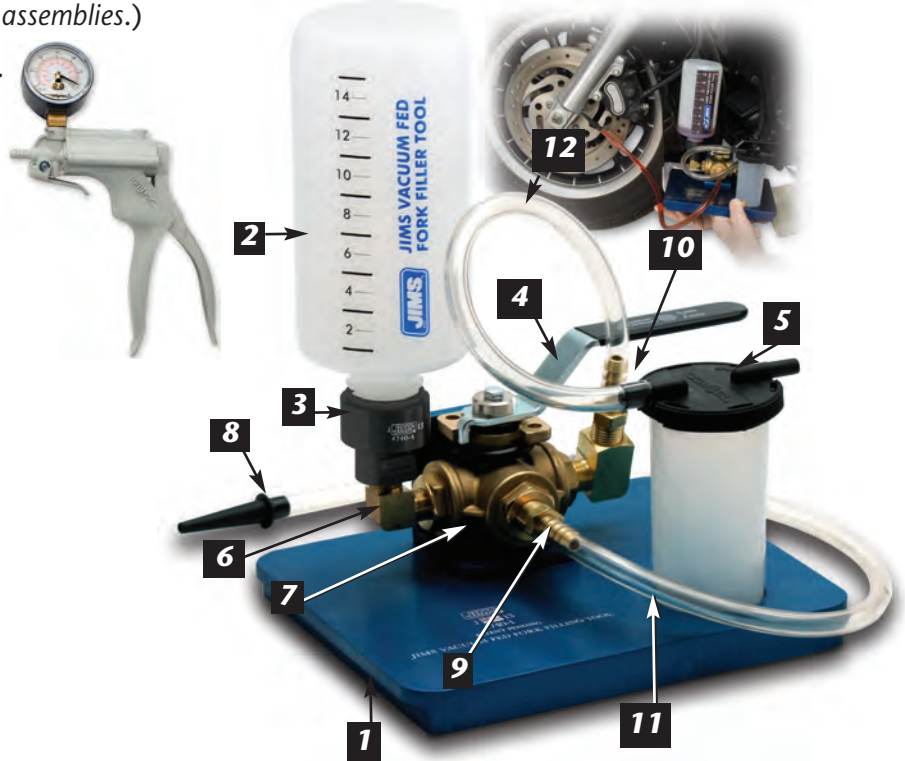

## NEW LATE MODEL NECK BEARING TOOL INSTALLER

A new frame design change in the steering head & neck bearings for Harley-Davidson® motorcycles necessitates a new installation tool. Pounding the races into place is simply not good enough. Compared to the OEM tool, this new JIMS® tool with smaller and tapered drivers, ensures optimal alignment and a fully installed depth. Both are essential for correct operation and service life of the steering head neck bearings. Needless to say, risks of damage to the bearing races and motorcycle frame are also avoided!

No. 5515 – Use on all 2014 to present FLH models. Including Tri Glide® trikes.

PARTS AVAILABLE SEPARATELY			
NO.	QTY.	DESCRIPTION	PART NO.
1	2	INSTALLER CUP	5515-1
2	1	STUD	1725-1
3	2	WASHER, 1/2" SAE	2038
4	2	NUT	1707-2
5	1	INSTRUCTION SHEET	5515-IS

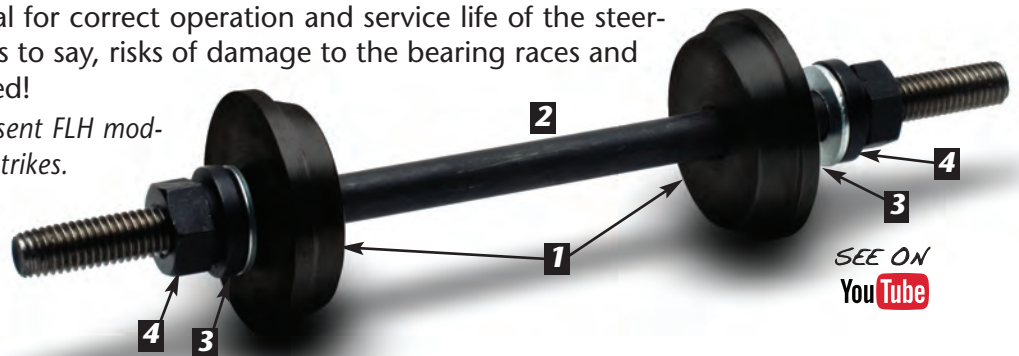

SEE ON  
YouTube

# JIMS® NEW PRODUCTS FRAME & FORK

## **NEW FORK CAP INSTALLATION TOOL**

Installing fork tube caps requires compressing the spring while rotating the cap. This is not particularly difficult with fork legs that have been removed from the bike and securely mounted in a work area. However, on the bike, the task can become almost impossible because of restricted work area and other components getting in the way. This tool allows a technician to install the fork tube caps on the motorcycle without removing other parts. Simply use two quick clamps, and the experienced technician can do the job in minutes!

No. 5821 - Use on all 49mm fork tubes.

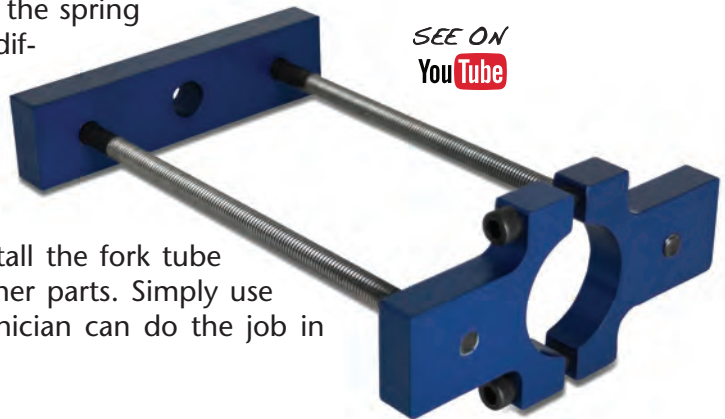

SEE ON  
YouTube



SEE ON  
YouTube

## **NEW FORK CAP ALLEN SOCKET**

Harley-Davidson® recently updated the fork cap on touring bikes, and you now need a large Allen head socket for disassembly. There's a good chance you don't have this size socket in your tool box, but there's no need to go buy an expensive kit just for this one socket. JIMS now offers a quality socket /driver for this application priced affordably and sold individually.

No. 5827 - Use on late model 49mm FLH forks on 2014 - present Touring models.

## **NEW SWING ARM BEARING INSTALLER**

Swing arm bearings must be installed and aligned accurately to avoid unsafe handling and ensure control of the motorcycle. Both drive side and brake side bearings, which are at different depths, can be easily and accurately installed with this tool kit. JIMS took it one step further and added a remover to press the spacer out of the bearing.

At JIMS we look out for technicians and riders alike.

No. 5822 - Use on 2002 - present FLH Touring Models.



JT'S RACING TEAM 2017



## 2014 WHEEL BEARING PULLER SUPPORT PLATE AND HUB PROTECTOR

On 2014-present cast wheels and certain CVO™/Accessory wheels, the brake rotor is attached by outboard mounts that provide no surface to support the bearing puller tool on the hub. JIMS No. 913 uses 2 of the rotor mounts to give a strong, stable surface for JIMS bearing puller to work without damaging the hub's finish. A unique counter bore prevents the puller from rotating and provides proper alignment and support for JIMS, OEM, and most other puller tools. It's made in the USA and guaranteed for life. If you have a 2014-present model or a repair shop, eventually you will need this tool. *For more details see No. 913-IS instructions.*

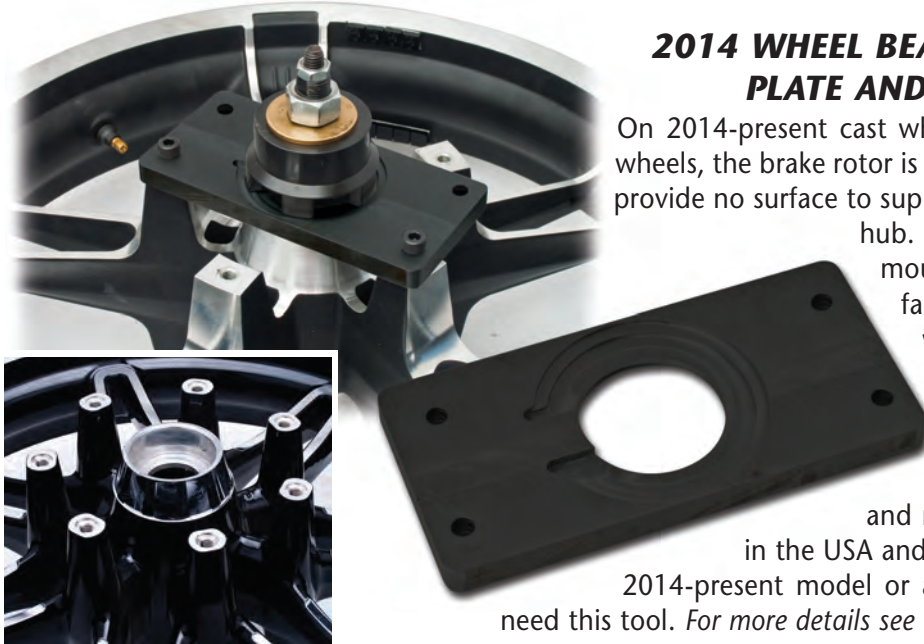

**WORKS ON  
5 OR 7 LUG WHEEL**

No. 913 - Use on H-D® cast wheels with 5 or 7 brake rotor mounting lugs outboard of wheel hub.

## LATE SEALED WHEEL BEARING REMOVER AND INSTALLER KIT

Use to remove and install "new style" sealed wheel bearings without damaging the wheel. Includes new remover and installer for 25mm bearing, with or without ABS. Also included is a 30 pack of "Surface Temperature Indicating Strips." These are used to assist in removing a stubborn bearing when applying heat to a hub surface. *For more details see No.1042-IS instructions.*

No. 939 - Use on all 2000-2016 Twin Cam models, and all 2000-present Sportsters® models, and V-Rod®s 2002-present.



## JIMS BLACK LOGO CAP

Whether covering helmet hair after a ride or protecting your face from the sun, this hat will keep you looking cool. JIMS Black Logo Cap is a 100% cotton New Era 9Fifty Snapback cap with an adjustable closure.

No. 2596 - One size fits most.



## **NEW AXLE INSTALLATION GUIDE**

Installation of motorcycle axles has always been problematic. Trying to align the wheel with other components such as swing arms, caliper brackets, wheel hubs and spacers can be frustrating - especially when trying to do the job alone. To help eliminate these problems, JIMS now offers an axle installation guide tool. This tool is exclusive to JIMS and was designed by our talented engineering partner, Hiro Koiso.

No. **5820** - Use on all 2008 - present hollow 1" / 25mm standard axles.



SEE ON  
YouTube



## **LOCKDOWN AXLE KIT**

High performance is much more than how much power a machine makes or how fast it will go. At JIMS, we know reliability and safety are also important. To these ends, we now offer our axle retention upgrade kit. The OEM axle nut washer can become weakened or deformed, and that can lead to loosening, even with a castle nut system. To avoid this loosening and the problems associated with it, we have developed a much stronger part to replace the washer, along with superior adjuster plates for the final drive. Our kit includes a special slotted axle nut washer part as well as stronger swing arm end caps that have a better fit into the swing arm. This is a great way to improve both reliability and safety. For more details see No. 1746-IS instructions.

No. **1746** - Use on 1991-2005 Dyna® Models.

No. **1747** - Use on 1979-04 XL, 1973-86 FL/FX and 1984 & 85 FXST Models.

No. **1748** - Use on 1980-2001 FLHT, 1982-2000 FXR.

### **PARTS AVAILABLE SEPARATELY**

QTY.	DESCRIPTION	PART NO.
2	ADJUSTING PLATE, DYNA	1746-2
1	AXLE WASHER, DYNA	1746-1
2	ADJUSTING PLATE, FX/FL/XL	1747-2
1	AXLE WASHER, FX/FL/XL	1747-1
2	ADJUSTING PLATE, FLHT/FXR	1748-2
1	AXLE WASHER, FLHT/FXR	1748-1
1	INSTRUCTION SHEET	1746-IS

## **HUB PROTECTOR FOR WHEEL BEARING TOOL**

Let's face it, wheel bearing tools are one of the first service tools needed in a technician's tool box. Thankfully, the JIMS® wheel bearing tool that is already in your tool box works for Indians® as well! All you need is this hub protector to do the job correctly without damaging the wheel. Thankfully, you don't have to buy the complete tool all over again to do the job right.

No. **5803** - Use on all Indian® models 2014-present and 2017 Victory® Octane.







# JIMS® NEW PRODUCTS LIFT & STAND

SEE ON  
YouTube

Easy Install



## MOTORCYCLE LIFT TOOL NEW AND LUBRICANT TRAY

Motorcycle lifts are typically just big enough to hold the bike and get it up to a convenient level to perform service. There is little space to keep tools, parts, fluids, chemicals, and sealants organized. Even with a rollaway tool box, the limited area on the lift base can become cluttered and disorganized. This durable powdercoated steel lift tray can keep parts and tools separated along with other necessary items. This patent-pending tray can easily be installed by simply drilling two 7/16" holes at the edge of your lift. Once the holes are drilled, the tray is conveniently removable so tools and lubricants can be brought back and forth to your workbench. Note, by drilling more than one set of holes, the tray can be used in multiple locations. For example: Cam Chest, Front Wheel, Rear Wheel and Primary locations. No. 5519 – Use on Handy® brand and most other bike lifts with 4" edge.

## BIKE LIFT WHEEL GUIDE

Today's larger and heavier motorcycles, especially those with fairings, can be difficult to safely load onto a bike lift by only one person. To solve this problem, JIMS® now offers a guide to help the front wheel track into the correct position. For use with Handy lift or equivalent, this device becomes the "buddy" that is needed to safely lead the motorcycle into the lift's front wheel vice. It may also work with wheel chocks in trucks or trailers used to transport motorcycles.

No. 5505 – Fits most bike lifts with front wheel vice.





# JIMS® NEW PRODUCTS LIFT & STAND



## NEW FUEL TANK WALL MOUNT

Fuel tanks that are removed from motorcycles can present storage problems. Tanks left on work benches or otherwise exposed invite disaster by being knocked to the floor or having objects dropped on them. The concept of fuel tank storage was brought to us by Kevin Baxter at Pro Twin Performance. If its base is securely mounted to a stud in a wall or other suitable mounting surface, a fuel tank can be easily and safely held out of harm's way. Additionally, fuel tanks can also be displayed for show and "wall art" purposes.

No. **5818** - Use on most one piece fuel tanks that use 5/16" or 3/8" hardware to mount fuel tank to the frame of the motorcycle.



## JIMS ROLLING BUDDY

Rubber mounted Harley-Davidson® V-Twins use the engine as a structural part of the chassis. When the engine is removed, it becomes impossible to roll the motorcycle. This can incapacitate a lift or, at the very least, tie up floor space. Our Rolling Buddy plates are designed to take the place of the engine and literally bolt the chassis back together. With our plate installed, the bike can easily be rolled, making the shop more efficient. We have done all the work for you: Measurements, materials, strength, and ease of installation are all there. Another quality, made in the USA product from JIMS that is guaranteed for life. For more details see No. 1134-IS instructions.

- No. **1134** - Use on Evo Touring, Dyna® and FXR Models.
- No. **1135** - Use on 1999-06 Touring & 1999-05 Dyna Models.
- No. **1136** - Use on 2007-2016 Touring & 2006-2016 Dyna.

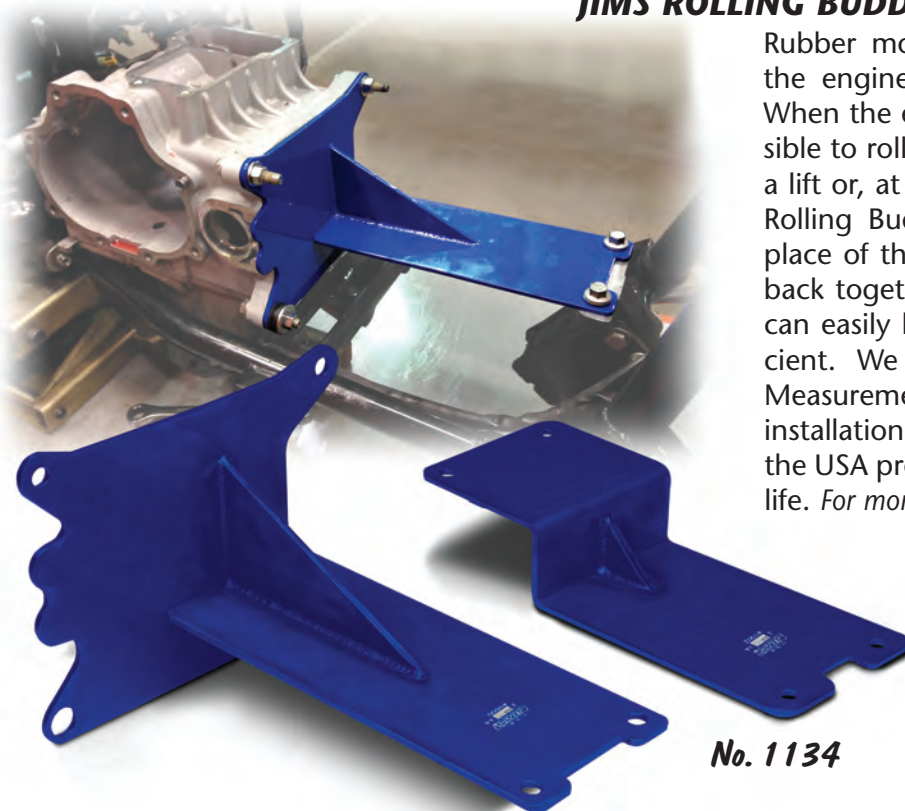

No. **1136**

No. **1134**

## HARDWARE ORGANIZER

Tired of hunting through plastic bins looking for hardware? The JIMS Hardware Organizers will guarantee all hardware is organized during powertrain teardown, storage, and final assembly. The organizers include a specific stand for top end, cam chest, transmission, and primary. When combined, they all nest within each other taking up very little space and can easily fit in a deep drawer of a tool box. When preparing for final assembly, the stands can be turned on end to expose threads for ease of loctite application. The surface is powder coated in durable JIMS blue and includes silkscreened hardware position art with select torque specifications. *For more details see No. 742-IS instructions.*

No. 742 - *Cam Chest - For cam cover, cam support and tappet cover hardware, 1999-2016 Twin Cam.*

No. 743 - *Primary - For inner and outer primary cover hardware, 1970-present Big Twin.*

No. 744 - *Top End - For top end and rocker cover hardware, 1999-present Twin Cam.*

No. 745 - *Transmission - For Cruise Drive transmission hardware, 2007-present Twin Cam and 2006 Dyna® models.*

No. 742K - *Complete Kit - Four piece hardware organizer kit listed above*

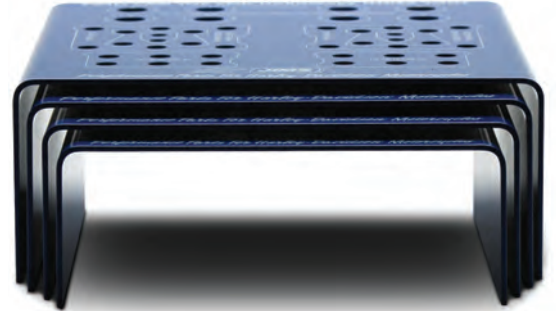

## SADDLEBAG LATCH RIVET TOOL

Saddlebag latch replacement or tightening occurs often enough that JIMS has developed a tool specifically for this purpose. This tool gives secure fastening while providing a clean factory look. To top it off, our tool is substantially less expensive than tools offered by others to do the same job, but ours still retains JIMS known quality. That is, our saddlebag latch rivet tool may be relatively inexpensive, but it is not cheap. Made in the USA, this tool also carries a lifetime guarantee. *For more details see No. 754-IS instructions.*

No. 754 - *Use to crimp saddlebag latch and hinge rivets.*

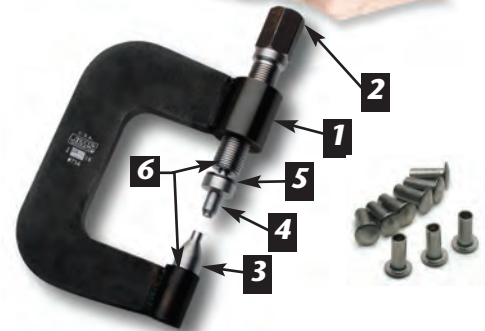

PARTS AVAILABLE SEPARATELY			
NO.	QTY.	DESCRIPTION	PART NO.
1	1	WELDMENT	754-8
2	1	SCREW	754-2
3	1	DEAD END	754-5
4	1	PILOT END	754-6
5	1	NICE BEARING	1186-1062
6	2	O-RING ( NOT SHOWN )	2059-5
7	1	INSTRUCTION SHEET	754-IS

**RIVETS ARE AVAILABLE AT  
YOUR LOCAL H-D DEALER**



# JIMS® NEW PRODUCTS COVERS



## TAPPET COVER

No. 6033 - Use on all 1999-2016 Twin Cam® engines. Not for JIMS Race Engines.

### PARTS AVAILABLE SEPARATELY

QTY.	DESCRIPTION	PART NO.
1	TAPPET COVER, REAR, BLACK	6033-1
1	TAPPET COVER, FRONT, BLACK	6033-2
8	SCREW, 1/4-20 X 1" SHCS BLK	2387
2	GASKET	862



## CAM COVER

No. 2301 - Use on all 2001-2016 Twin Cam engines.

### PARTS AVAILABLE SEPARATELY

QTY.	DESCRIPTION	PART NO.
1	CAM COVER	2301-1
10	SCREW, 1/4-20X1 1/4	2383
1	GASKET	879



## JIMS® BILLET TRANSMISSION TOP COVER

JIMS® Billet aluminum transmission top cover is made from 6061-T6 aircraft quality aluminum. Covers come with gasket and chrome allen screws. Replaces OEM No.(chrome) 34468-98 or No.(polished) 34464-98.

No. 8999PK - (Polished kit) Use on 1998-1999 FLH and Softail® and 6-speed models.

No. 8999CK - (Chrome kit) Same as above. **CHROME**

No. 8999BK - (Black Kit) Same as above.

**NOTE:** Will fit 1987-97 FLH and FXST models when using H-D® No.33902-98 switch and H-D® No.33320-98 shifter drum.

## JIMS BLACK HANDCRAFTED AND WELDED COVERS

Many of JIMS customers have asked for our welded covers to be finished in black, to match today's "blacked out" models. We listened. This unique blend of precision machined aluminum with the individual styling of a 'hand welded' cover, is now available in anodized black!



## CRUISE DRIVE TRANS COVER

No. 2396 - Use on all 2006-present H-D® Cruise Drive 6-Speed transmission.

### PARTS AVAILABLE SEPARATELY

QTY.	DESCRIPTION	PART NO.
1	CRUISE DRIVE COVER, HANDCRAFTED, BLK	2396-1
6	SCREW, 1/4-20 X 1 SHCS, BLK	2387
1	GASKET	877



## 5-SPEED TRANS COVER

No. 2398 - Use on all 1987-2006 Big Twin 5-speed and aftermarket 6-speed transmissions with minor hardware change. (Not for use on FXR with mid controls).

### PARTS AVAILABLE SEPARATELY

QTY.	DESCRIPTION	PART NO.
1	5 SPEED COVER, HANDCRAFTED, BLK	2398-1
6	SCREW, 1/4-20 X 1 1/4" SHCS, BLK	2383
1	GASKET	36801-87A



## SPECIALTY TOOLS FOR USE ON INDIAN MOTORCYCLES

### **NEW WATER PUMP SEAL(S) INSTALLER**

There is a water pump seal on the new Indian Scout located in the engine case that requires a tool for installation. In testing, we discovered an additional seal "hidden below". JIMS has taken the time to develop a seal installer that installs BOTH seals to the proper location and depth. Coolant filled engines might be new for some of us, but at JIMS, we try to take the time to do it right the first time.

No. **5801** – Use on 2015-present Indian® Scout and 2017 Victory® Octane models.



#### PARTS AVAILABLE SEPARATELY

NO.	QTY	DESCRIPTION	PART NO.
1	1	SEAL DRIVER	5801-1
2	1	SHAFT, WATER PUMP SEAL TOOL	5801-2
3	1	FLANGE NUT, 12MMX1.75	5801-3
4	1	INSTRUCTION SHEET	5801-IS

### **NEW FLYWHEEL (ROTOR) PULLER**

Factory tools are some of the best tools you can buy. Similar to the OEM tool, the JIMS tool incorporates a design change to ensure good and solid engagement when using the puller. This subtle change might eliminate potential damage to the flywheel when used in this application.

No. **5800** – Use on 2015-present Indian® Scout and 2017 Victory® Octane models.



#### PARTS AVAILABLE SEPARATELY

NO.	QTY	DESCRIPTION	PART NO.
1	1	PULLER BODY	5800-1
2	1	WASHER, 3/8" FLAT, GRADE 8	5800-2
3	1	SCREW	1024
4	1	INSTRUCTION SHEET	5800-IS

### **NEW FORK COMPRESSION SOCKETS**

Again, JIMS has added subtle design changes to improve this tool for the motorcycle technician. The O.D. of the socket, as well as the profile of the face, have been improved for proper use.

No. **5802** – Use on 2015-present Indian® Scout and 2017 Victory® Octane models.





# SECTION

Dealer No.  
\_\_\_\_\_

<b>ENGINE.....</b>	<b>PREFACE</b>
<b>CYLINDER HEAD COOLER, FUEL INJECTION .....</b>	<b>1</b>
<b>CYLINDER, PISTON, &amp; FLYWHEEL KITS .....</b>	<b>2</b>
<b>STROKER ACCESSORIES.....</b>	<b>3</b>
<b>IGNITION .....</b>	<b>4</b>
<b>PISTONS .....</b>	<b>5</b>
<b>ROLLER ROCKER ARMS, &amp; SHAFTS.....</b>	<b>6</b>
<b>VALVES, GUIDES, &amp; SEATS .....</b>	<b>7</b>
<b>SPRINGS, PUSHRODS, &amp; CAMS .....</b>	<b>8</b>
<b>TAPPETS, &amp; TAPPET BLOCKS.....</b>	<b>9</b>
<b>LATCH COVERS, &amp; FRONT HEAD MOUNT .....</b>	<b>10</b>
<b>HANDCRAFTED COVERS.....</b>	<b>11</b>
<b>CAM COVERS, CAM BEARINGS, &amp; BUSHINGS .....</b>	<b>12</b>
<b>CRANK PINS, &amp; HARDWARE .....</b>	<b>13</b>
<b>SPROCKET SHAFTS, PINION SHAFTS, &amp; HARDWARE.....</b>	<b>14</b>
<b>ROD ROLLERS, RACES, &amp; BUSHINGS .....</b>	<b>15</b>
<b>OIL PUMPS, HARDWARE, &amp; BREATHER GEARS .....</b>	<b>16</b>
<b>STARTERS, CABLES, &amp; CLUTCHES .....</b>	<b>17</b>
<b>TRANSMISSIONS, &amp; PARTS .....</b>	<b>18</b>
<b>GASKETS, &amp; SEALS.....</b>	<b>19</b>
<b>COMPLETE TOOL SECTION .....</b>	<b>SEE TAB 20</b>

# TABLE OF CONTENTS

3rd Hand Axle Tool	209	Installer/Remover	171	Cam Bearing Puller Tools	151
49MM Dust & Fork Seal Installer Tool	205	Balancer Tools	171-172	Cam Bearing, Go No Go Gauges, EVO, Shovel	154
4-Speed Mainshaft Clutch Gear Puller	204	Battery Cables	95	Cam Bushing Reamer, EVO, Shovel	153
5/4 Transmission	104	BDM Diagnostic Tool	139	Cam Bushings	72
5-Speed for a 4-Speed Frame	104	Bearing & Race Puller Tool	179	Cam Chain Tensioner Tool	154
5-Speed Super Kit	106	Bearing Grease Packer	216	Cam Cover Bushing Remover, EVO, Shovel	158
5-Speed Super Kit for a 4-Speed Frame	106	Belt Drive Tension Gauge	211	Cam Cover Heat Sink	69
6/4 Transmission	104	Beta Balancer Inner Bearing Remover/Installer	172	Cam Cover Holder, EVO, Shovel	158
6-Speed for a 4-Speed Frame	104	Beta Case Support Block Tool	183	Cam Cover Installer Drill Jigs, Single Cam	157
6-Speed Super Kit	105	Beta Engine Interconnect Seal Leak Tester	138	Cam Cover Seal Installer, EVO, Shovel	157
6-Speed Super Kit for 4-Speed Frame	105	Big Bore Gasket Sets	26	Cam Cover, Welded Handcrafted	68
<b>A</b>		Big Bore Kits, Twin Cam	13, 18	Cam Covers	68, 70
Accelerator Software	130	Bike Center Jack	214	Cam Gear Alignment Tool, EVO, Shovel	156
Adjustable Pushrod Kits 45-46, 55		Bike Pocket	69	Cam Gear Remover Tool, EVO, Shovel	156
Adjustable Torque Wrench		Billet Cam Covers	68, 70	Cam Lube	225
Adapter	220	Billet Front Head Motor Mount	67	Cam Relief Tool, EVO, Shovel	155
Air Cleaner Backing Plate	17	Billet Oil Pump	90-91	Cam Relief Tool, Twin Cam	155
Air Fuel Ratio Diagnostic Sniffer	137	Billet Pushrod Tube Kits & Spacers	44, 68	Cam Relief Tool, XL	155
Air Fuel Ratio Monitoring System	137	Billet Saddlebag Latch Covers	67	Cam Tools	151-159
Alternator Rotor Remover Tool	143	Blue Threadlocker	223	Cam, EVO	47
Angled Feel Gauge	149	Brake & Wheel Tools	216	Cam/Crank Sprocket Locker Tool	154
Anti Seize Lubricant	223	Brake Bleeder Kit	216	Case Bore Tools & Adapters	168-169
Antique Shafts	76	Brake Caliper Piston Remover Tool	216	Case Bushings	88
Assembly Lube	223	Brass Hammer	221	Case Lap Tool, Single Cam	170
Audio Isolation Tool	136	Breather Gear Shims	93	Case Saver Tappet Reamer	147
Axle Tools	209	Breather Gears	93	Case Splitter	184
<b>B</b>		Breather Reamer Tool, Single Cam	156	Chain & Belt Alignment Tool	210
Backing Plate, EFI & Carbureted	17	<b>C</b>		Chain Press Tool Kit	211
Bagger Latch Covers	67	Cable Luber	221	Chains & Belt Drive Tools	211
Bagger rivet Tool	219	Cages	85	Chemicals, Lubricants & Supplies	223
Balancer Hydraulic Retainers	172	Caliper Piston Remover	216	Circuit Breaker Shaft & Bushing Kit	82
Balancer Shaft Alignment Tool	172	Cam & Pinion Gear Gauge Pins, Single Cam	159	ClevoBlock Bushing Assembly Remover/Installer Tool	208
Balancer Shaft Remover Tool	172	Cam Assembly Tool, Twin Cam	153		
Balancer Shaft Retention Pins	171	Cam Bearing	71		
Balancer Shift Bearing		Cam Bearing & Bushing Alignment Tool	154		
		Cam Bearing Gauge, EVO, Shovel	154		
		Cam Bearing Installer Tools	152		



# TABLE OF CONTENTS

Cleveblock Spreading Tool	208	Cylinder Torque Plate Tools	166-167	Flywheel Assembly, Twin Cam	21
Clothing	226-228	<b>D</b>		Flywheel Nut Sockets	176
Clover Lapping Compound	170, 224	Diagnostic Tools	136-139	Flywheel Nuts	77
Clutch - High Performance Kit	96	Dickies Work Shirt	228	Flywheel Rebuilding Tool	173
Clutch Assembly Service Tool, Big Twins	191	Dipstick Socket	186	Flywheel Runout Inspection Gauge	175
Clutch Drum Ring Gear	95	Drive Pulleys	121	Flywheel Tools	173
Clutch Fiber Sets	97	Drum Upgrade	120	Flywheel Truing Stand	173
Clutch Hub Pullers, Big Twin	193	Dual Gauge Leakdown Tester	138	Flywheel Truing Tool	173
Clutch Lock Plate, 4-Speeds	191	Dyna Switch Lock Remover	141	Flywheel Weld Service	22
Clutch Spring Compressor, XL192		<b>E</b>		Forceflow, Cylinder Head Cooler	14
Clutch Spring Tool, XL	192	EFI	15-16	Forged Piston Sets	18, 29-30
Clutch Tools	191-193	EFI Pressure Gauge	134	Fork Leg & Tube Holder	206
Clymer Service Manuals	222	Electrical Tools	141-143	Fork Nut Socket	205
Compensator Shaft Wrench	189	End Play Gauge	175	Fork Oil Level Gauge	207
Compression Release Tap	144	Engine & Transmission Plug Kit, Twin Cam	218	Fork Seal & Cap Installer	205
Compression Release Valve Tool	144	Engine Assemblies 120, 131, 135	7-12	Fork Shifter Shaft	120
Compression Release Valves	27	Engine Assembly Lube	223, 225	Fork Stem Bearing Remover	206
Compression Tester	138	Engine Case Bushings	88	Fork Tube Filler Cap Nut Socket	205
Conical Valve Spring Collar	145	Engine Dipstick Socket	186	Fork Tube Holder	206
Connecting Rod Bearing Set	85	Engine Stands	218	Fork Tube Spring Retainer Remover/Installer	206
Connecting Rod Bushing Tool	161	EVO Billet Cam Cover	70	Frame Thread Chasers	221
Connecting Rod Cages	85-86	EVO Cams	47	Front Fork Compressor Tool	206
Connecting Rod Races	89	EVO Cylinder Stud Jig Tool, EVO, XL	167	Front Fork Tools	205-207
Connecting Rod, Twin Cam	22	EVO Tappet Block Kits	61-62	Front Head Motor Mount	67
Cooler, Forceflow, Cylinder Head	14	Exhaust Gasket Seal Installer	149	Fuel Injection	15-16
Copper Anti Seize Lubricant	223	Exhaust Pipe End Shaper	221	Fuel Pressure Test Gauge	134
Countershafts	113	Exhaust Stud Drill Plate	149	Fuel Pump Retainer Remover/Installer Tool	141
Crank Disassembly Removing Tool	184	Extended Fork Compressor Adapter Tool	206	<b>G</b>	
Crank Pin Nuts	77	External Lock Ring Pliers	203	Gas Tank Pressure Gauge	134
Crank Pins & Kits	74-76	<b>F</b>		Gasket Locator Tool	189
Crankshaft Bearing Installer/Remover	177	Fat 5-Speed Overdrive Transmission	100-101	Gasket Sets	26, 123-126
Crankshaft Bearing Tool	177	Fat 5-Speed Super Kit	100-101	Gear Sets, 5-Speed	113
Crankshaft Guide	178	Fat Tire Main Drive Gears	113	General Tools	220
Cutting Fluid, Tap Magic	225	Fat Tire Mainshafts	113	<b>H</b>	
Cylinder & Piston Kit, Twin Cam	13, 18	Feeler Gauge	149	Hand Cleaner	224
Cylinder Case Bore Tools	168-169	Filler Cap Socket	205	Handcrafted Welded Cam Covers	68
Cylinder Head Cooler	14	Filter Cutter Tool	188	Handcrafted Welded Covers	68
Cylinder Tools	166-167	Five Speed Transmissions	102-104	Handcrafted Welded Trans Side Cover	68, 111
		Flywheel Assemblies, EVO, Carbureted	23		

# TABLE OF CONTENTS

Handy Packer, Bearing Packer	216	Lifters	48-59	Single Cam	187
Head Bolt Torque Gauge	148	Lock-up Clutch Kit	96	Oil Pump Tools	186-187
Head Bolts	33	Lower End Keys	83	Oil Pumps	90-91
Head Holder Tool	144-145	<b>M</b>		Orange Hand Cleaner	224
Heat Sink	69	Main Drive Gear Tools	202	Outer Balancer Bearing	
High Heat Anti Seize Lubricant	223	Mainshaft & Countershaft		Installer/Remover	171
Hollow Axle Plug Tool	209	Bushings	117	Outer Cam Bearing Remover,	
Hose Repair Kit	138	Mainshaft Race Puller Tool	196	Twin Cam	153
Hot Lap Twin Cam Tappet	50, 57	Mainshaft Seal Tools	195-196	Outer Primary Starter Bearing	
Hydraulic Tappets	50-58	Manifold Spacers, EFI	26	Remover Tool	190
Hydrosolid Tappets	52-54, 58	Manifold, Carbureted	26	Oxygen Sensor Thread Chasers	134
		Manifold, EFI	16	Oxygen Sensor Tools	134-135
<b>I</b>		Master Link Pliers	211	<b>P</b>	
Idler Gear Shaft	82	Mechanic's Stethoscope	220	Picstick for Video Scope	136
Ignition & Fuel Pump Tools	141	Mega Nuts	121	Pin Bushings	89
Ignition Module, Carbureted	13, 28	Mighty Bite Flywheel Lock	176	Pinion Bushing Installer Drill Jigs	159
Ignition Switch		Mini Valve Spring Tester	132, 145	Pinion Bushing Line Reamer	170
Connector/Remover Tool	141	Modular Engine & Transmission		Pinion Bushing Puller, Single	159
Indian Drive Shaft	76	Stands	217	Cam	159
Inline Spark Tester	143	Module, Carbureted	13, 28	Pinion Bushings	73
Inner & Outer Cam Bearings	71	Motor Assemblies	7-12	Pinion Gear Installer/Remover	185
Inner & Outer Primary Cover	97	Motorcycle Alignment Tool	210	Tool	185
Inner Cam Bearing Installer Tools	152	<b>N</b>		Pinion Gear Lock Tools, Twin	185
Inner Cam Bearing Puller Tool	151	Neck Cup Installer	207	Cam, XL	185
Inner Primary Bearing & Seal		Neck Cup Race Remover Tool	207	Pinion Gear Nut Socket	185
Installer/Remover	190	Neck Race Installer	207	Pinion Gear Tools	185
Inner Primary Cover Tools	190	Neutral Switches	109	Pinion Gears	84
Inspection Cover Tool, XL	189	Nitrile Disposable Gloves	224	Pinion Shaft Bearing Sets	87
<b>J</b>		<b>O</b>		Pinion Shaft Hardware	82
JIMS Bike Pocket	69	O2 Sockets & Wrenches	135	Pinion Shaft Nuts	77
Jumbo Chain Tool	211	Offset Sprockets	122	Pinion Shafts & Spacers	80-81
<b>K</b>		Oil Filler Spout Spacer	103	Piston Jet Test Stand	131
Keys	83	Oil Filter Cutter Stand	188	Piston Oiling Jets	27
Kick Starter Parts	122	Oil Filter Cutter Tool	188	Piston Ring Compressor Tool	165
<b>L</b>		Oil Filter Tools	188	Piston Ring End Gap File	165
Lapping Compound	170, 224	Oil Jets	27	Piston Ring End Gap Tool	164
Latch Covers	67	Oil Pump Alignment Screws	160, 186	Piston Ring Groove Cleaner	165
Left Case Tools	181-184	Oil Pump Drive Shaft Kits	92	Piston Rings	18, 29-30
Lift Caddy	132	Oil Pump End Covers	91	Piston Sets	18, 29-30
Lift Caddy & Bike Center Jack	214	Oil Pump Gears	92	Piston Support Plate	163
Lifter Blocks	60-66	Oil Pump Keys	83	Piton Tools	163-165
Lifter Tester	131	Oil Pump Parts	92	Pivot Bearing Remover/Installer	
		Oil Pump Seal Installer	186	Tool, Softails	208
		Oil Pump Snap Ring Installer,		Plastic Scraper	224



# TABLE OF CONTENTS

Plug Kit, Twin Cam Engine & Transmission	219	Rocker Arm Bushing or Bearing Puller	150	Solid Tappets & Hardware	56, 58-59
Points Cover	69, 70	Rocker Arm Bushing Reamer	150	Sound Isolation Tool	136
Powerglide™ Tappets	48-49, 51, 53-55, 57	Rocker Arm Bushings & Roller Hardware	34	Spark Plug Thread Chasers	142
Powertrain Alignment Tool, Touring Models	210	Rocker Arm Sets	31-32	Spark Tester	143
Primary Cover Kit	97	Rocker Arm Shafts	33	Speedo Transmission Parts	119
Primary Drive Tools	189-190	Rocker Cover Ratchet Wrench	148	Spoke Wrench	215
Primary Locking Bars	189	Rod Alignment Tool	161	Spout Spacer	103
Pulley Locker Tools	194	Rod Bushings	89	Spring Compressor Tool	145
Pulley Tools	194	Rod Holder Tool	161	Sprocket Bearing Installer Tool, Big Twin	178
Pulleys	121	Rod Race Installer Tool	162	Sprocket Bearing Installer Tool, XL	178
Pump Retainer Tool	141	Rod Race Lapping Set	162	Sprocket Shaft Bearing Nut	
Pushrod Cover Clip Installer Tool	44, 145	Rod Races	89	Wrench	183
Pushrod Cover Seal/Seat Cutter, Single Cam	160	Rod Rollers	85-86	Sprocket Shaft Bearing Tools	178
Pushrod Kit	45-46, 55	Rod Tools	161-162	Sprocket Shaft Bearing Tools	181-182
Pushrod Tube Covers & Spacers	44, 68	Rods, Twin Cam	22	Sprocket Shaft Hard Cap	184
		Roller Bearings	85-87	Sprocket Shaft Holders	173-174
		Roller Rocker Arm Sets	31-32	Sprocket Shaft Nuts	77
		Rotor Remover Tool	143	Sprocket Shaft Race Handle Tool	181
		RSD Super Kits	99		
		RSD Transmission	98-99	Sprocket Shaft Race Remover/Installer	181
		Rubber Gloves	224	Sprocket Shaft Rotators	174
				Sprocket Shaft Seal Installer	181
<b>R</b>				Sprocket Shaft Seal Installer	183
Race & Bearing Installer/Remover Handle	152, 181, 207, 213	<b>S</b>		Sprocket Shaft Spacers	81
Real Wheel Compensator Bearing Remover/Installer Tool	213	Saddlebag rivet Tool	219	Sprocket Shafts	79
Reamer, Rocker Arm Bushing	150	Safer Scraper	224	Sprockets	122
Reamers, Valve Guides	38, 147	Scantool, Diagnostics	139	Staking Dowel Pin for Bushings	158
Rear Axle Nut Torque Adapter Tool	209	Seat Installer/Remover Tool	207	Star Receptacle Extractors	142
Rear Fork Bearing Remover/Installer Tool	208	Service Manuals	222	Started Jack Seal Installer	190
Rear Wheel Alignment Tool	209	Shift Fork Gauge Tools	204	Starter Button Tool	143
Receptacle & Pin Extractor	142	Shift Fork Shaft Remover Tool, Cruise Drive	203	Starter Ring Gear Kit	95
Red Threadlocker	223	Shifter Drum Kit	120	Starter Ring Gear Rivet Fixture	191
Remote Start Button	143	Shifter Drum Parts	120	Starters	94
Retention Pins	171	Shifter Levers	119	Steel O-Clip Pincer Tool	187
Right Side Drive Transmission	98-99	Shifter Shaft Case Sleeve Remover/Installer	203	Steering Head Stem Nut Wrench	205
Ring Compressor Tool	165	Shifter Shaft Seal Tools	195	Stem Nut Wrench	205
Ring File	165	Shovel Tappet Block Kits	60, 64-66	Stroker Accessories	26-27
Ring Groove Cleaner Tool	165			Stroker Flywheel Assemblies,	
Ring Installer Tool	164	Six Speed Overdrive Transmissions	102-104		
rivet Tool	219	Slim Jim Filter Wrench	188		
Rocker Arm Bushing Installer Tool	150	Sniffer, AFR Tool	137		
		Soft Vice Jaws	220		
		Solid Brass Hammer	221		





# JIMS® COMPLETE TWIN CAM® 135" RACE ENGINES

## FEATURES & OPTIONS:

- ONE YEAR FACTORY WARRANTY
- CUSTOMIZING OPTIONS
- 131" BIG BORE KIT
- "EVOLUTION® MOUNT" TWIN CAM
- NIGHT TRAIN® ENGINE COVER SET
- DIAMOND CUT CYLINDER HEADS



 **NEW FOR 2012**

- 135 CI's
- 2212 CC's
- 2.2 Liter
- 135" & 131" WELDED FLYWHEELS
- IMPROVED OIL PUMP
- NOT STREET LEGAL

**JIMS**  
U.S.A.

**AVAILABLE ONLY THROUGH  
AUTHORIZED H-D® DEALERS**



# JIMS® COMPLETE TWIN CAM® 135” RACE ENGINES

## JIMS 135” TWIN CAM RACE ENGINE

The NEW 135” engine has new performance features never before offered. This engine comes with a new 4-5/8” stroke and has a bore diameter of 4-5/16”. JIMS R&D Team continually adds updated improvements as product becomes available. JIMS has added the new Hi Volume Screamin Eagle oil pump to further enhance the performance of this engine beyond the standard O.E.M. pump. Throw in a brand new JIMS Billet Cam Support Plate, to accommodate the new pump which utilizes Harley-Davidson’s hydraulic cam chain tensioner, and finish it off with the latest in high-performance “JIMS Powerglide™II”. Also new for the 135” are the new Screamin Eagle 266 lift cams. Cylinder heads are CNC ported heads and are developed to flow effortlessly. Heads come with JIMS Roller Rocker Arms and billet support plates. As always, power delivery is as smooth off the bottom end as stock, with a wide powerband of roll-on punch. These enhancements, plus 136HP\* and 135ft-lbs of torque, take the 135” to an unmatched level of performance and reliability. All are available through authorized Harley-Davidson dealerships. For more details see JIMS No. 1208-1355 owners manual. For more information contact your local H-D® dealer or visit our web-site at [www.jimsusa.com](http://www.jimsusa.com).

**NOTE:** Oil or cylinder coolers are recommended on all performance engines. See page 14 for “JIMS Forceflow” cylinder cooler.

JIMS Assembled Race Engines are now backed by a **1 year warranty.**



**NEW**  
**HI-VOLUME**  
**OIL PUMP**



**136 HP**  
**135 TQ**  
**RACE ONLY!**

### HIGH PERFORMANCE COMPONENTS INCLUDES

- Screamin’ Eagle® Adjustable Pushrods
- ARP® Cylinder Studs
- JIMS Forged Pistons
- JIMS Pressed & Welded Flywheel Assembly
- H-D Hydraulic Cam Chain Tensioner
- Screamin’ Eagle Valve Springs
- JIMS Cylinders
- Black High Lift Rocker Covers
- JIMS Edition RSD Clarity Cam Cover
- ARP Case Bolts
- JIMS Billet Cam Support Plate
- JIMS Roller Rockers Arms
- JIMS Powerglide™II
- CNC Ported Heads
- SE 266 Cam
- SE High Flow Oil Pump
- JIMS Fat Tube Pushrod Covers
- JIMS Engine Cases
- Forged Rocker Support Plates
- Timken Bearing

### 135” TWIN CAM RACE KIT SPECIFICATIONS

- Horsepower: 136
- Torque: 135
- Bore Size: 4 5/16”
- Stroke: 4 5/8”
- Compression: 10.67:1
- Cam Lift: .658”
- Intake Valve: 2.120”
- Case Material: A356-T1
- Connecting Rods: 4340
- Recommended Octane: 91

\*Horsepower and Torque performance measured at the rear wheel with a Dynojet® Dynamometer. Your results may vary based on E.F.I. Induction (Non-carbureted), camshaft and exhaust combination. This is not a street legal engine.



## 135” TWIN CAM ENGINE WITHOUT CARB / IGNITION

Part No.	Color	Description
2608-3530	Black	07-Pres. Touring & 06-Pres. Dyna
2608-3535	Silver	07-Pres. Touring & 06-Pres. Dyna
2208-3530	Black	99-06 Touring & 99-05 Dyna
2208-3535	Silver	99-06 Touring & 99-05 Dyna

**AVAILABLE ONLY THROUGH  
AUTHORIZED H-D® DEALERS**



# JIMS® COMPLETE TWIN CAM® 131” RACE ENGINES

## JIMS 131” TWIN CAM RACE ENGINE

The 131” features the same stroke as the JIMS 120” at 4 1/2”, but carries a larger bore diameter of 4 5/16”. JIMS R&D Team has added many new features to further enhance the performance of this engine. First, to feed air to the 131”, CNC Ported Heads were developed that flow air effortlessly. Next, we upgraded the oil pump to the high flow design found in all current production Harley-Davidson® Twin Cam Engines. Throw in a brand new JIMS Billet Cam Support Plate, which utilizes Harley-Davidson’s new hydraulic cam chain tensioner, and finish it off with the latest in high-performance tappets, JIMS Powerglide™II. As always, power delivery is as smooth off the bottom as stock, with a wide powerband of roll-on punch. These enhancements, plus 130HP\* and 135ft-lbs of torque, take the 131” to an unmatched level of performance and reliability.

All are available through authorized Harley-Davidson® dealerships. For more information contact your local H-D® dealer or visit our web-site at [www.jimsusa.com](http://www.jimsusa.com).

**NOTE:** Oil or cylinder coolers are recommended on all performance engines. See page 14 for “JIMS Forceflow” cylinder cooler. JIMS Assembled Race Engines are now backed by a **1 year warranty.**



**130 HP  
135 TQ  
RACE ONLY!**

### HIGH PERFORMANCE COMPONENTS INCLUDE

- Screamin’ Eagle® Adjustable Pushrods
- ARP® Cylinder Studs
- JIMS Forged Pistons
- JIMS Pressed & Welded Flywheel Assembly
- H-D Hydraulic Cam Chain Tensioner
- Screamin’ Eagle Valve Springs
- JIMS Cylinders
- JIMS Billet Cam Support Plate
- JIMS Roller Rockers
- JIMS Powerglide II Tappets
- CNC Ported Heads
- Screamin’ Eagle Cams
- H-D High Flow Oil Pump
- JIMS Engine Cases

### 131” TWIN CAM ENGINE WITHOUT CARB / IGNITION

Part No.	Color	Description
1308-3530	Black	1999-2006 Touring and 1999-2005 Dyna®
1708-3530	Black	2007-Later Touring 2006-Later Dyna
1308-3535	Silver	1999-2006 Touring and 1999-2005 Dyna
1708-3535	Silver	2007-Later Touring 2006-Later Dyna
1508-3530	Black	2000-2006 Softail
1508-3535	Silver	2000-2006 Softail
2108-3530	Black	2007-Later Softail
2108-3535	Silver	2007-Later Softail

### 131” TWIN CAM RACE KIT SPECIFICATIONS

- Horsepower: 130
- Torque: 135
- Bore Size: 4.313”
- Stroke: 4.500”
- Compression: 10.5:1
- Cam Lift: .658”
- Intake Valve: 2.120”
- Case Material: A356-T1
- Connecting Rods: 4340
- Recommended Octane: 91

\*Horsepower and Torque performance measured at the rear wheel with a Dynojet® Dynamometer. Your results may vary based on E.F.I. Induction (Non-carbureted), camshaft and exhaust combination. This is not a street legal engine.

**AVAILABLE ONLY THROUGH  
AUTHORIZED H-D® DEALERS**

# JIMS® COMPLETE TWIN CAM® 120" RACE ENGINES

## JIMS 120" TWIN CAM RACE ENGINES

Delivering 125 HP\* and 121 ft-lbs of torque is just the beginning. JIMS thick-walled cases offer unmatched strength and can support a bore size of up to 4.800. This engine features pressed flywheels, forged pistons, Screamin' Eagle® valve springs, forged 4340 steel connecting rods and the latest in high performance tappets, JIMS Powerglide™II. From the ground up, this engine has everything needed to stop the competition in its tracks, and the track is what this engine was designed for. Since 2004, JIMS has set the standard in High-Performance Twin Cam Racing Engines, and we are just getting started!.

**NOTE:** Oil or cylinder coolers are recommended on all performance engines. See page 14 for "JIMS Forceflow" cylinder cooler.

### HIGH PERFORMANCE COMPONENTS INCLUDE

- Screamin' Eagle Adjustable Pushrods
- JIMS Roller Rockers
- JIMS Powerglide II Tappets
- JIMS Pressed & Welded Flywheel Assembly
- JIMS Cylinder
- ARP® Cylinder Studs
- JIMS Forged Pistons
- Screamin' Eagle Cams
- Screamin' Eagle Valve Springs
- JIMS Engine Cases

**125 HP  
121 TQ  
RACE ONLY!**

### 120" TWIN CAM RACE KIT SPECIFICATIONS

- Horsepower: 125
- Torque: 121
- Bore Size: 4.125"
- Stroke: 4.500"
- Compression: 10:1
- Cam Lift: .658"
- Intake Valve: 2.120"
- Case Material: A356-T1
- Connecting Rods: 4340
- Recommended Octane: 91

Softail®



**120" TWIN CAM ENGINE  
WITHOUT CARB / IGNITION**

Part No.	Color	Description
1408-3530	Black	2000-2006 Softail
1408-3535	Silver	2000-2006 Softail
2008-3530	Black	2007-Later Softail
2008-3535	Silver	2007-Later Softail

Touring & Dyna®



**120" TWIN CAM ENGINE  
WITHOUT CARB / IGNITION**

Part No.	Color	Description
1208-3530	Black	1999-2006 Touring and 1999-2005 Dyna
1608-3530	Black	2007-Later Touring 2006-Present Dyna
1208-3535	Silver	1999-2006 Touring and 1999-2005 Dyna
1608-3535	Silver	2007-Later Touring 2006-Present Dyna

\*Horsepower and Torque performance measured at the rear wheel with a Dynojet® Dynamometer. Your results may vary based on E.F.I. Induction (Non-carbureted), camshaft and exhaust combination. This is not a street legal engine.

**AVAILABLE ONLY THROUGH  
AUTHORIZED H-D® DEALERS**



# JIMS® COMPLETE TWIN CAM® 135", 131" & 120" WITH EVOLUTION® MOTOR MOUNT

## JIMS 135", 131" & 120" TWIN CAM EVOLUTION MOTOR MOUNT RACE ENGINE

JIMS R&D Department has developed 135", 131" & 120" Twin Cam Race Engines that bolt directly into Evolution motor mount style frames. Now the reliability and performance of Twin Cam technology is available for most OEM Harley-Davidson® applications back to 1991, as well as most custom frames designed to accept Evolution engines. **NOTE:** Oil or cylinder coolers are recommended on all performance engines. See page 14 for "JIMS Forceflow" cylinder cooler.



**NEW**

**IMPROVED OIL PUMP**

Does not include Carb

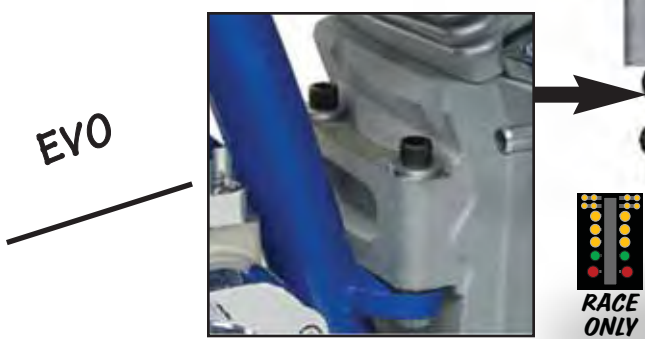

**135" TWIN CAM RACE KIT SPECIFICATIONS**

- Horsepower: 136
- Torque: 135
- Bore Size: 4 5/16"
- Stroke: 4 5/8"
- Compression: 10.67:1
- Cam Lift: .658"
- Intake Valve: 2.120"
- Case Material: A356-T1
- Connecting Rods: 4340
- Recommended Octane: 91

**136 HP  
135 TQ  
RACE ONLY!**

### 135" TWIN CAM® ENGINE WITHOUT CARB / IGNITION **NEW**

Part No.	Color	Description
2808-3530	Black	1991-98 Touring and Dyna®, 1991-99 Softail®*
2808-3535	Silver	1991-98 Touring and Dyna®, 1991-99 Softail®*

\*135" Engines come with upgraded features see page 8 for details.

**131" TWIN CAM RACE KIT SPECIFICATIONS**

- Horsepower: 130
- Torque: 135
- Bore Size: 4.313"
- Stroke: 4.500"
- Compression: 10.5:1
- Cam Lift: .658"
- Intake Valve: 2.120"
- Case Material: A356-T1
- Connecting Rods: 4340
- Recommended Octane: 91

**130 HP  
135 TQ  
RACE ONLY!**

### 131" TWIN CAM® ENGINE WITHOUT CARB / IGNITION

Part No.	Color	Description
1908-3530	Black	1991-98 Touring and Dyna®, 1991-99 Softail®
1908-3535	Silver	1991-98 Touring and Dyna, 1991-99 Softail

**120" TWIN CAM RACE KIT SPECIFICATIONS**

- Horsepower: 125
- Torque: 121
- Bore Size: 4.125"
- Stroke: 4.500"
- Compression: 10:1
- Cam Lift: .658"
- Intake Valve: 2.120"
- Case Material: A356-T1
- Connecting Rods: 4340
- Recommended Octane: 91

**125 HP  
121 TQ  
RACE ONLY!**

### 120" TWIN CAM® ENGINE WITHOUT CARB / IGNITION

Part No.	Color	Description
1808-3530	Black	1991-98 Touring and Dyna, 1991-99 Softail
1808-3535	Silver	1991-98 Touring and Dyna, 1991-99 Softail

\*Horsepower and Torque performance measured at the rear wheel with a Dynojet® Dynamometer. Your results may vary based on E.F.I. Induction (Non-carbureted), camshaft and exhaust combination. This is not a street legal engine.

**AVAILABLE ONLY THROUGH AUTHORIZED H-D® DEALERS**

# CUSTOM ENGINE PROGRAM



## **CUSTOM LETTERING IN LOGO PAD**

It's your engine, so let everyone know! JIMS® is now offering CNC custom lettering on the cylinder heads. Just one of the many options that JIMS is offering to help you build your own custom engine. Choose up to eight letters per cylinder head.

No.1000-0001 - Use on 120", 131" or 135" Twin Cam® Engines.



## **DIAMOND CUT CYLINDERS AND HEADS**

This patented diamond look is created by making hundreds of cuts in the outer edge of the cooling fins. These cuts make the motor look fantastic because the cuts are placed at the perfect angle to reflect light. It is that reflection of light that makes them sparkle and shine.

No.1000-0002 - Use on 120" or 131" Twin Cam Engines.



## **NIGHT TRAIN® ENGINE COVER SET**

Going for that blacked out look? Now you can order your engine with these covers installed by JIMS. These covers are OEM Harley-Davidson® covers that have been clearanced for roller rocker arms. Rest assured that the color match is perfect. Along with that comes the quality, fit, and finish that is Harley-Davidson.

No.1000-0003 - Use on all Twin Cams using Roller Rocker Arms.



## **10.5:1 JIMS COMPRESSION HOP-UP**

Looking for that extra edge? Here is one way to gain power over the 120" stock configuration. Increasing compression is just one way of many that will increase horsepower in the JIMS 120". Developed, tested and proven during 131" development and now an option for all 120" engines.

No.1000-0012 - Use on JIMS Heads. Use on all JIMS 120" Twin Cam Engines.

**AVAILABLE ONLY THROUGH  
AUTHORIZED H-D® DEALERS**



## DO YOU HAVE A 120" AND WISH YOU HAD A 131"?



### JIMS® 131" BIG BORE KIT...

An easy solution to convert your JIMS 120" into a 131". These kits are designed to work with an existing JIMS 120" Race Engine. The kit includes a set of 4 5/16" JIMS cylinders and a set of 4 5/16" JIMS pistons. These are the same cylinders and pistons used in the JIMS 131" race engine. Since the 131" engine was based on the same stroke as the 120", other parts, including the flywheel assembly, cams, etc... can still be used. With simple case boring - and this kit - your 120" can be converted into the awesome 131" engine. Kit includes head and base gaskets and a center case bolt.

With proper induction, exhaust and head modifications, this Big Bore kit will easily match the power output of the JIMS 131" race engine. This kit offers a great cost alternative for the customer that has already purchased a JIMS 120" engine. See instruction sheet No.1308-1350 on JIMS website. Use JIMS case bore tool No.1400 on page 168.

- No.1000-0010 - JIMS 131 Big Bore Kit (Black) Use on all 1999 to present Alpha's JIMS 120" Twin Cam® Engines
- No.1000-0011 - JIMS 131 Big Bore Kit (Silver) Use on all 1999 to present Alpha's JIMS 120" Twin Cam® Engines



### NEW JIMS® TWIN CAM CARBURATED RACE ENGINE IGNITION



This is the perfect match up for your 120", 131" or 135" performance race engine. JIMS R&D department developed this program to give you instant acceleration off the line and smooth and even transition through the gears. This unit has the OEM style plug connector and is easy to install. This product is not included with engines. Order separately.

- No.2344 - Use on all 1999 to 2003 Alpha 120", 131" or 135" carbureted engines.
- Use on all 2000 to 2003 Beta 120", 131" or 135" carbureted engines.

See your local authorized Harley-Davidson dealer and build your custom engine today. For more information contact your local H-D® dealer or visit our web-site at [www.jimsusa.com](http://www.jimsusa.com)

**AVAILABLE ONLY THROUGH  
AUTHORIZED H-D® DEALERS**



## THE JIMS FORCEFLOW CYLINDER HEAD COOLER

This smooth streamline design will keep your Twin Cam® running cooler on those hot July summer days in stop and go traffic. JIMS® R & D department has come up with a serious way to drop your head temperature by as much as 100 degrees. Although this mounts in the horn area JIMS has designed a horn relocater hidden inside the fan housing. The fan can be installed to be turned on and off manually or it can be regulated by a thermostat controlled sensor that monitors head temperature and activates the fan when engine temperature rises. This kit is highly recommended for performance motors to help extend engine life. Complete kit includes high powered fan, housing, horn, hardware and all wiring, along with detailed instructions. *For more details see No. 5400-IS instructions.*



**USE ON 99-PRESENT TWIN CAM TOURING MODELS & OTHER MODELS WITH SOME FABRICATION.**  
(Kit installs from horn location & is supported by center case bolt location.)

- No. 5400 - Polished Cylinder Head Fan kit.
- No. 5401 - Black Cylinder Head Fan kit.
- No. 5402 - Silver Cylinder Head Fan kit.
- No. 5447 - JIMS Engine Hardware Mounting kit.



This solid model view shows the fan housing with high velocity fan and supplied relocated mini horn.

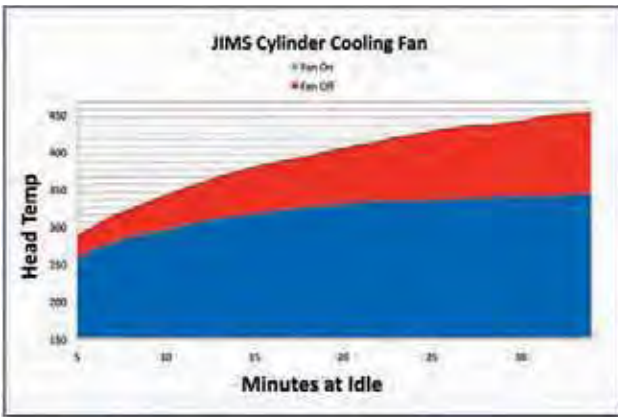

It's common knowledge that heat is one of an engines worst enemies. In developing

the JIMS cylinder head cooler, JIMS had to sacrifice a few motors for the cause. We tested worse case scenario by letting engines idle in the sun for over a half hour each while recording cylinder head temperatures minute by minute. Above represents the average temperature reduction of all testing combined. The JIMS Cylinder Head Cooler will help an engine operate and stabilize at lower temperatures.





# ELLIPTICAL ADVANTAGE

The New JIMS® Performance 53mm, 58mm, & 62mm Throttle Body & Manifold.

1

## An Elliptical Designed For Quick Throttle Response.



Use on 120", 131", or 135" JIMS® Engines or others using Screamin' Eagle® or other performance heads. Use on 2006-present FXD, FXST and 2006 or 2007 FLH that use a mechanical throttle cable type system. **NOTE:** Will not work on any Electronic throttle systems (Throttle by wire) **FOR RACE APPLICATION ONLY.**

JIMS® Throttle Bodies feature an Elliptical intake track, producing a constant plenum that lends itself to either low RPM torque engines or high RPM horsepower engines. An "Elliptical Curve" starts at the air box (air filter) all the way thru the Elliptical Throttle Body into the intake manifolds plenum. This Elliptical curve will aid in volumetric efficiency. With this increased induction high velocity track tuning "Elliptical Curve", coupled with an exhaust system that includes good scavenging capabilities, reversion can be minimized. JIMS® Ellipse 53mm, 58mm, and 62mm Throttle Bodies have outstanding performance when installed on all EFI 2006 to present mechanical throttle cable style motorcycles. They are compatible with all O.E.M. electrical components (i.e. throttle position sensors, air control motors, fuel injector assemblies, etc). Also compatible with most ignition systems H-D® and or aftermarket, making sure the system that is installed with JIMS® Ellipse has enough tuning capability for the size engine you will be tuning. The manifold is also wider to fit most taller engines and is available in two sizes. Use on all 100" to 135" Twin Cam® motorcycles. **Throttle Body and manifold are sold separately because of different cylinder heights.** They come with while supply last or without electronic components, MAP sensor, Fuel Rails, and Injectors. See the following pages for manifold kits, and air cleaner backing plates kits available. See parts list and illustrations on next page. For more details see No. 5202-IS & No.5275-IS instructions.



The Elliptical Air Flow Advantage For Quick Throttle Response.

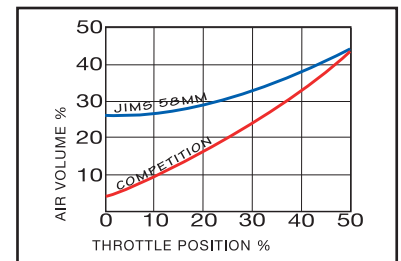

### THROTTLE BODY WITH ELECTRONIC COMPONENTS

Part No.	Description
No.5209	53mm Throttle Body (Manifold Sold separately)
No.5215	58mm Throttle Body (Manifold Sold separately)
No.5221	62mm Throttle Body (Manifold Sold separately)

### THROTTLE BODY WITHOUT ELECTRONIC COMPONENTS

Part No.	Description
No.5210	53mm Throttle Body (Manifold Sold separately)
No.5216	58mm Throttle Body (Manifold Sold separately)
No.5222	62mm Throttle Body (Manifold Sold separately)

# FUEL INJECTION

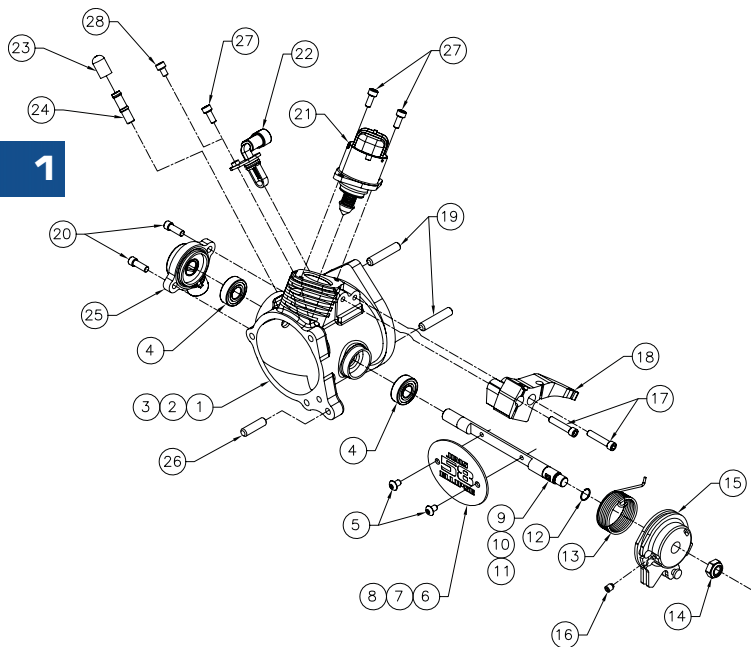

## JIMS FUEL INJECTION ELLIPTICAL MANIFOLDS

These JIMS Elliptical manifolds must be used with JIMS Throttle Bodies shown on the previous pages. They are available with while supply last or without the manifold components. If you currently have a stock throttle body and manifold many of these components can be transferred to the JIMS manifold and throttle body. To view details of electronics while supply last or other components supplied with manifolds see No. **5202-IS** instruction.

PARTS AVAILABLE SEPARATELY			
NO.	QTY.	DESCRIPTION	PART NO.
1	1	53MM MACHINED THROTTLE BODY	5225-53
2	1	58MM MACHINED THROTTLE BODY	5225-58
3	1	62MM MACHINED THROTTLE BODY	5225-62
4	2	BEARING, BALL, SEALED	5256
5	2	SCREW, 8-32 (THROTTLE PLATE)	5264
6	1	53MM THROTTLE PLATE	5226-53
7	1	58MM THROTTLE PLATE	5226-58
8	1	62MM THROTTLE PLATE	5226-62
9	1	53MM THROTTLE SHAFT	5227-53
10	1	58MM THROTTLE SHAFT	5227-58
11	1	62MM THROTTLE SHAFT	5227-62
12	1	RETAINING RING, THROTTLE SHAFT	5266
13	1	SPRING, REEL RETURN	5258
14	1	NUT, 5/16-24	5267
15	1	CABLE REEL	5228
16	1	SET, SCREW, 10-32 (CABLE HOLDER/ GUIDE)	5271
17	2	SCREW, 10-32 (CABLE HOLDER/GUIDE)	5271
18	1	CABLE HOLDER, GUIDE	5231
19	2	STUD, 1/4-20	5262
20	2	SCREW, 10-32 (POSITION SENSOR)	1294
21	1	IDLE MOTOR H-D 27658-06 (NOT SUPPLIED IN 5221 & 5215)	5253
22	1	TEMP SENSOR H-D 27381-06 (NOT SUPPLIED IN 5221 & 5215)	5252
23	1	CAP, AIR TUBE	5260
24	1	AIR TUBE	5259
25	1	POSITION SENSOR H-D 27689-06 (NOT SUPPLIED IN 5221 & 5215)	5251
26	1	SET SCREW 1/4-20	5268
27	3	SCREW, 8-32 X 1/2" (TEMP & IDLE)	5270
28	1	SCREW, 8-32 X 3/8"	2297
29	1	INSTRUCTION SHEET	5202-IS

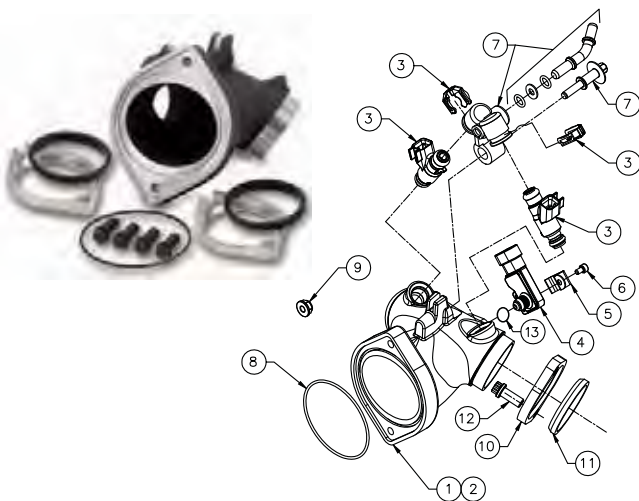

### MANIFOLD WITH ELECTRONIC COMPONENTS

Part No.	Description
No.705	Use on engines with stock cylinder height, or JIMS® Race Engines 120", 131" & 135". Will work on stock cylinder length to plus .100" longer cylinders.
No.707	Use on engines having cylinders longer then plus .125"

PARTS AVAILABLE SEPARATELY			
NO.	QTY.	DESCRIPTION	PART NO.
1	1	INTAKE MANIFOLD, STOCK MOTOR	5239-1
2	1	INTAKE MANIFOLD, TALL MOTOR	5239-2
3	2	S.E. INJECTOR (NOT SUPPLIED IN 704 & 706) H-D 27654-06	5255
4	1	MAP SENSOR W/ SEAL (NOT SUPPLIED IN 704 & 706) (H-D 32424-98)	5250
5	1	BRACKET, MAP (H-D38723-99)	5269
6	1	SCREW, 8-32 (MAP BRACKET)	1220
7	1	FUEL RAIL, ASSEMBLY (NOT SUPPLIED IN 704 & 706 (H-D 27651-06)	5254
8	1	O-RING	5261
9	2	NUT, 1/4-20 FLANGE NUT, NYLON	5263
10	2	FLANGE, INTAKE (H-D 27059-05A)	5272
11	2	SEAL, FLANGE, INTAKE (H-D27035-05)	5273
12	4	SCREW, 5/16-18 X 3/4", 12 POINT	5274
13	1	SEAL, MAP SENSOR	11291
14	1	INSTRUCTION SHEET	5202-IS

### MANIFOLD WITHOUT ELECTRONIC COMPONENTS

Part No.	Description
No.704	Use on engines with stock cylinder height, or JIMS® Race Engines 120", 131" & 135". Will work on stock cylinder length to plus .100" longer cylinders.
No.706	Use on engines having cylinders longer then plus .125"



# EFI & CARB AIR CLEANER BACKING PLATE KITS



## JIMS RACE FLOW AIR CLEANER BACKING PLATE KIT NOW AVAILABLE IN CHROME OR BLACK. ALSO AVAILABLE FOR STOCK APPLICATIONS



JIMS Race Flow Air Cleaner Chrome Backing Plate Kit was developed in response to the growing popularity of the JIMS Race Flow Breather Kits. The backing plate is now offered for most H-D Delphi throttle bodies, and most H-D CV carburetors. From the ground up JIMS made no compromise and machined our backing plate out of solid 6061 T-6 billet aluminum with built in spacers (breather mounts). These backing plates can be installed in minutes and boast the ultimate in strength and rigidity. As an additional benefit we have added o-ring grooves which eliminate the time consuming shimming and oil leaks found in other backing plates. By bolting on the supplied air filter, gaskets, o-rings, and hardware you get a built in crankcase head breather system that helps control oil carry over. This gives you an advanced air breather ported system, and with some simple installation you are bolting on increased

airflow! Air cleaner covers equivalent to O.E.M. H-D® No. 29121-07 which also can be used. The Race Flow Breather Kit now ships in Dealer Packaging for added sales exposure. For more details see No.5275-IS instructions.



1

**No. 5275 Black -** Use on JIMS® 53mm, 58mm, & 62mm Elliptical Throttle Bodies and Screamin' Eagle Pro Super Bore 51mm CV Carburetor No. 27928-07.  
**No. 5286 Chrome**

**No. 5276 Black -** Use on all 2008- 2012 stock H-D throttle body – electronic throttle (fly by wire) also fits Screamin' Eagle Pro High Flow 58mm EFI throttle Screamin' Eagle Pro High Flow 58mm EFI throttle body No.27713-08 and Screamin' Eagle Pro High Flow 58mm EFI throttle body – cable operated throttle No.27639-07.  
**No. 5287 Chrome**

**No. 5285 Black -** Fits 00 to present Softail, 99 - 07 Touring (except 99 - 01 EFI models), also fits 08 - present Dyna models equipped with accessory air cleaners. Fits EFI models and carbureted models with original equipment CV, Screamin Eagle CV ( except CV 51mm Super Bore), and Flatslide carburetors. Also fits 06 - 09 CVO Electra Glide, 09 CVO and Road King, 09 CVO Road Glide, 08 - 09 CVO Springer and 09 CVO Dyna models with separate purchase of Air Cleaner Cover H-D P/N 29121-07 or accessory air cleaner cover. Stock on 05 15th Anniversary FLSTF, 05 - 07 CVO Softail, 07 - 08 CVO Dyna, and 07 CVO Road King models.  
**No. 5288 Chrome**

### PARTS AVAILABLE SEPARATELY

NO.	QTY.	DESCRIPTION	PART NO.
1	3	SCREW, 1/4-20 X 1/2", BHCS, BLK, AIR ELEMENT	8090
2	1	AIR ELEMENT (H-D® #29244-08 OR K&N #HD-0818)	5277
3	3	STANDOFF, FILTER	5279
4	2	PLUG, BLACK BACKING PLATE	5278-1
5	2	BOLT, BREATHER, VENTED	5283
6	1	BACKING PLATE, BLACK, JIMS EFI	5281-1 & 5280-1
7	1	BACKING PLATE, BLACK, HD EFI	5282-1 & 5280-1
8	1	BACKING PLATE, BLACK, STOCK DELPHI EFI	5284-1 & 5280-1
9	1	BACKING PLATE ASSY, CHROME, JIMS EFI	5289
10	1	BACKING PLATE ASSY, CHROME, 58MM EFI BY WIRE	5290
11	1	BACKING PLATE ASSY, CHROME, STOCK DELPHI	5291
12	1	GASKET, BACKING PLATE, JIMS EFI	876
13	3	SCREW, 1/4-20 X 1 1/4", BHCS, BLK, BACKING PLATE	2166
14	2	O-RING, BREATHER STANDOFF	874
15	1	GASKET, BACKING PLATE, HD 58MM BY WIRE EFI	875
16	1	GASKET, BACKING PLATE, FOR STOCK DELPHI	884
17	2	PLUG, CHROME, BACKING PLATE	5275-2
18	1	INSTRUCTION SHEET	5275-IS

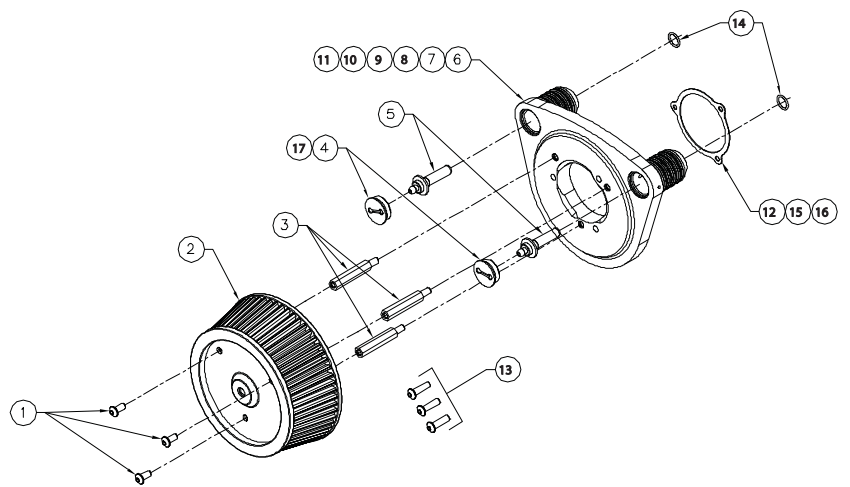

# TWIN CAM CYLINDERS & PISTON SET

## JIMS® TWIN CAM® CYLINDERS AND PISTON KITS

### 100" TO 117" CYLINDER AND PISTON KITS

These 100" to 117" cylinder kits are designed to be used with original Twin Cam® Harley-Davidson® flywheel sets and engine cases. Kits include a pair of JIMS® black or silver cylinders. The cylinders fit the original O.E.M. cylinder stud bolt pattern. Pistons are a premium flat top forged set with rings using .927" pins with JIMS® piston jets (if required) per kit size. For more details see No.1551-IS instructions. Order gasket sets separately. See catalog page 26.

### 120" TO 124" CYLINDER AND PISTON KITS

These larger big bore kits are designed to be used with JIMS® Twin Cam® flywheel assemblies only as listed on catalog page 21. You can also update an earlier JIMS® Twin Cam® 113" or 116" stroker kit to a larger cubic inch with these kits. Kits include JIMS® black or silver cylinders. Cylinders fit O.E.M. cylinder stud bolt pattern. Pistons are a premium flat top forged set with rings using .927" pins with JIMS® piston jets. Gasket sets sold separately on page 26. For more details see No.1551-IS instructions.

1. These kits require you to increase the size of the engine case cylinder spigot bores for larger cylinders. To perform this modification use JIMS® case bore tool No.1408. See catalog page 168. For more details see No.1177-IS instructions.
2. When increasing bore size and stroke, JIMS® highly recommends that for 2003 to present Twin Cam® models you convert the left crankcase bearing to the more durable H-D® No. 9028 Timken® bearing. Use a JIMS® Timken® conversion tool No.959. For more details see No.959-IS instructions and catalog page 133.



100"*	106"*	110"*	117"***	120"***	124"***
ALPHA 99-06 BETA 00-06 WITH H-D® FLYWHEELS	ALPHA 99-06 BETA 00-06 WITH H-D® FLYWHEELS	ALPHA 07-PRESENT WITH H-D® FLYWHEELS	ALPHA 07-PRESENT WITH H-D® FLYWHEELS	USE WITH JIMS ALPHA F/W KITS No.1881 OR 1882 OR BETA No.1886 ON PAGE 21	USE WITH JIMS ALPHA F/W KITS No.1883 OR 1884 OR BETA No.1888 ON PAGE 21

### CYLINDER SPECIFICATIONS

Alpha & Beta Black Cylinder w/Piston Set	No.1501B	No.1519				
Alpha & Beta Silver Cylinder w/Piston Set	No.1501	No.1520				
Alpha Black Cylinder w/Piston Set			No.1521	No.1523	No.1525	No.1527
Alpha Silver Cylinder w/Piston Set			No.1522	No.1524	No.1526	No.1528
Beta Black Cylinder w/Piston Set					No.1548	No.1550
Beta Silver Cylinder w/Piston Set					No.1549	No.1551
Stroke	4"	4"	4.375"	4.375"	4.5"	4.625"
Bore	4"	4.125"	4"	4.125"	4.125"	4.125"
Cylinder Length	4.915"	4.915"	5.018"	4.915"	5.018"	5.018"

### FORGED PISTON SPECIFICATIONS

Standard Piston Set Part No.'s	No.1603	No.1614	No.1615	Alpha No.1616	Alpha No.1611	Alpha No.1617
Standard Piston Set Part No.'s					Beta No.1613	Beta No.1618
2 Piston Ring Set Standard No.'s	No.1491	No.1286-1354	No.1491	No.1286-1354	No.1286-1354	No.1286-1354
Compression Height	1.27	1.27	1.1750	1.0825	1.1990	1.1250
* Compression W/ Stock H-D® 85cc Head	9.56:1	10.00:1	10.00:1			
** Compression W/ S. E. 95cc Head				10.5:1	10.5:1	10.5:1
Oversize +.010 Piston Set	No.1622	No.1623	No.1624	No.1625	Alpha No.1626	Alpha No.1627
Oversize +.010 Piston Set					Beta No.1628	Beta No.1629
2 Piston Ring Set O/S +.010	No.1493	No.1286-1806	No.1493	No.1286-1806	No.1286-1806	No.1286-1806

**NOTE:** For oversize pistons for above kits contact JIMS sales dept. **NOTE:** Please allow 4 weeks for oversize pistons. **NOTE:** See page 29 for piston weights.



## ALPHA TWIN CAM STROKER KITS



**RACE ONLY**



JIMS® RECOMMENDS:
JIMS® Engine Gasket Kit
JIMS® Compression Releases
Performance Heads
Performance Induction System
Performance Exhaust
Performance Ignition
JIMS® Oiling Jets (Supplied)
Performance Cam
JIMS® Rocker Arms
JIMS® Adjustable Pushrods
JIMS® Performance Tappets
JIMS® EFI Spacer Kit
JIMS® Case Boring Tool

### 113" TWIN CAM® FXD, FL, STROKER KITS W/VHR™ \*

PART NO.	APPLICATION	STROKE	BORE	FLYWHEEL DIA.	COMPRESSION RATIO	CYLINDER FINISH
No.1943	Use on Alpha 2006-present FXD or Alpha 2007-present FL	4 1/2"	4" STD	8 1/4"	9.94:1(Stock Heads)**	Wrinkle Black
No.1944		4 1/2"	4" STD	8 1/4"	9.94:1(Stock Heads)**	Silver
No.1937	Use on Alpha 1999-05 FXD or Alpha 1999-06 FL	4 1/2"	4" STD	8 1/4"	9.94:1(Stock Heads)**	Wrinkle Black
No.1938		4 1/2"	4" STD	8 1/4"	9.94:1(Stock Heads)**	Silver

### 116" TWIN CAM® FXD, FL, STROKER KITS W/VHR™ \*

PART NO.	APPLICATION	STROKE	BORE	FLYWHEEL DIA.	COMPRESSION RATIO	CYLINDER FINISH
No.1945	Use on Alpha 2006-present FXD or Alpha 2007-present FL	4 5/8"	4" STD	8 1/4"	10.19:1(Stock Heads)**	Wrinkle Black
No.1946		4 5/8"	4" STD	8 1/4"	10.19:1(Stock Heads)**	Silver
No.1941	Use on Alpha 1999-05 FXD or Alpha 1999-06 FL	4 5/8"	4" STD	8 1/4"	10.19:1(Stock Heads)**	Wrinkle Black
No.1942		4 5/8"	4" STD	8 1/4"	10.19:1(Stock Heads)**	Silver

JIMS® now offers both early and late Twin Cam® 116" and 113" flywheel sets. These Alpha flywheel assemblies were designed to be installed in a stock engine case by boring the cases to accommodate 4" bore cylinders. Use a JIMS® case bore tool to perform the bore modification to your case. See catalog pages 168. JIMS® has joined performance and reliability together with the development of the Twin Cam® Stroker assemblies. JIMS® 3-piece Twin Cam® flywheel assemblies feature an integral pinion shaft and sprocket shaft for maximum stability and resistance to flywheel distortion. Each kit ships pre-balanced and is assembled with a press-fit, OEM proven crank pin is combined with the JIMS® bullet proof H-beam 4140 forged machined connecting rods. Flywheel assemblies, use forged blanks instead of conventional billet material for improved strength. JIMS® cylinders are manufactured from aerospace quality cast aluminum and steel. Now with VHR™ (Vertical Horizontal Ribbing) technology, cylinder casting to cylinder sleeve adhesion is effectively and uniformly locked throughout the entire cylinder casting. This VHR™ technology, combined with proprietary cylinder body geometry, equalizes the cylinder top to bottom (for optimum cylinder concentricity) when placed under torque load. Stroker cylinders are enhanced with eleven equally spaced fins improving the total fin pack surface area by 25%. Cylinders seamlessly blends into existing OEM components. From the precise base surface and fin pack alignments, exact OEM finish and hidden cast seams, JIMS® cylinders are designed to increase the durability and longevity of your performance engine. Kits come with a complete set of JIMS® premium dished forged pistons, and a pair of piston oiling jets and complete instructions to install this stroker kit. For more details see No.1932-IS instructions.

**NOTES:** 1. Must order 113" or 116" gasket sets and EFI spacer kit separately. See page 26.

\*\*2. Compression ratio based on 85.9cc head with .040" head gasket and 9.5cc piston dish at zero deck height. Case machining required for 4" cylinders.

3. For proper installation of JIMS stroker kits on 2003 and later cases, JIMS® strongly recommends you convert the left crankshaft bearing to the H-D® 9028 Timken. Use JIMS® No.959 Timken Conversion Kit to perform this operation.

SEE JIMSUSA.COM FOR DETAILED INSTRUCTIONS

## TWIN CAM® BETA STROKER KITS

These Beta flywheel assemblies were designed to be installed in a stock engine case by boring the cases to accommodate 4" bore cylinders. Use a JIMS® case bore tool to perform the bore modification to your case. See catalog page 168. JIMS® cylinders are designed to blend into the stock appearance of the motor and are available in either silver or black powder coat wrinkle finish. Kits come with a complete set of JIMS® premium dished forged pistons, piston oiling jets, and complete instructions to install this kit. Gaskets must be ordered separately. See catalog page 26. For more details see No.1932-IS instructions.



### 113" TWIN CAM® SOFTAIL STROKER KITS

PART NO.	APPLICATION	STROKE	BORE	FLYWHEEL DIA.	COMPRESSION RATIO	CYLINDER FINISH
No.1957	Use on Beta Softails 2000-06	4 1/2"	4" STD	8 1/4"	9.94:1(Stock Heads)**	Wrinkle Black
No.1958	Use on Beta Softails 2000-06	4 1/2"	4" STD	8 1/4"	9.94:1(Stock Heads)**	Silver

### 116" TWIN CAM® SOFTAIL STROKER KITS

PART NO.	APPLICATION	STROKE	BORE	FLYWHEEL DIA.	COMPRESSION RATIO	CYLINDER FINISH
No.1959	Use on Beta Softails 2000-06	4 5/8"	4" STD	8 1/4"	10.19:1(Stock Heads)**	Wrinkle Black
No.1960	Use on Beta Softails 2000-06	4 5/8"	4" STD	8 1/4"	10.19:1(Stock Heads)**	Silver

#### NOTES:

- 1: Must order 113" or 116" gasket sets and EFI spacer kit separately. (See page 26.)
- \*\*2: Compression ratio based on 85.9cc head with .040" head gasket and 9.5cc piston dish at zero deck height. Case machining required for 4" cylinders.
3. For proper installation of JIMS stroker kits on 2003 and later cases, JIMS® strongly recommends you convert the left crankshaft bearing to the H-D® 9028 Timken. Use JIMS® No.959 Timken Conversion Kit to perform this operation. See page 133.

JIMS® RECOMMENDS:
JIMS® Engine Gasket Kit
JIMS® Compression Releases
Performance Heads
Performance Induction System
Performance Exhaust
Performance Ignition
JIMS® Oiling Jets (Supplied)
Performance Cam
JIMS® Rocker Arms
JIMS® Adjustable Pushrods
JIMS® Performance Tappets
JIMS® EFI Spacer Kit
JIMS® Case Boring Tool



## TWIN CAM® ALPHA & BETA STROKER FLYWHEEL ASSEMBLIES

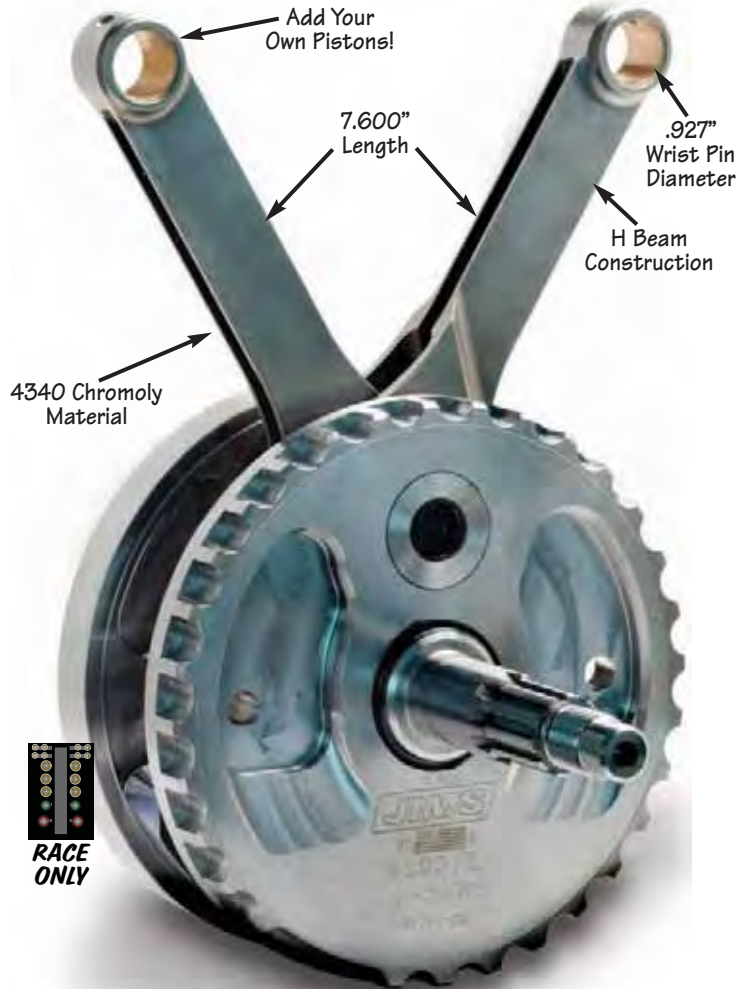

**RACE ONLY**

**1.671" CRANK PIN & STOCK ROD ROLLERS INCREASE RIGIDITY AND LOAD CAPACITY.**



### TWIN CAM® ALPHA & BETA

JIMS® now offers both early or late Twin Cam® Alpha flywheel sets and early Beta's. These Alpha or Beta flywheel assemblies were designed to be installed in a stock engine case by boring the cases to accommodate 4" to 4-1/8" bore cylinders. Use a JIMS® case bore tool to perform the bore modification to your case. See catalog page 168. JIMS® 3-piece Twin Cam® flywheel assemblies feature an integral pinion shaft and sprocket shaft for maximum stability and resistance to flywheel distortion. Each kit ships assembled with a press-fit. The OEM proven crank pin is combined with JIMS® bullet proof H-beam 4140 forged machined connecting rods. Flywheel assemblies use forged blanks instead of conventional billet material for improved strength.

**NOTE:** When increasing to a larger bore size and stroke, JIMS® highly recommends on the 2003 to present Twin Cam® models that you convert the left crankcase bearing to the more durable H-D® No. 9028 Timken® bearing. Use JIMS® Timken® conversion tool No.959 to perform this operation. For more details see No.959-IS instructions and catalog page 133.

#### BALANCING INFORMATION

To maintain JIMS® balance factor for the smoothest engine performance possible, you will need to install a 2 piston set having a total weight, including all rings, wrist pin and wrist pin keepers. Use pistons weighing between 1125g to 1145g when building with the following flywheel parts numbers: 1881, 1882, & 1886, for 4-1/2" stroke. Use a 2 piston set weighing between 1125g to 1135g when building with the following flywheel parts numbers, 1883, 1884, & 1888, for 4-5/8" stroke.

### TWIN CAM® ALPHA STROKER FLYWHEEL ASSEMBLIES (WITHOUT PISTONS)

PART NO.	APPLICATION	STROKE	WRIST PIN BUSHING	FLYWHEEL DIA.
No.1881	Use on Alpha 2006-present FXD or Alpha 2007- present FL.	4 1/2"	0.927" I.D.	8 1/4"
No.1882	Use on Alpha 1999-05 FXD or Alpha 1999-06 FL.	4 1/2"	0.927" I.D.	8 1/4"
No.1883	Use on Alpha 2006- present FXD or Alpha 2007- present FL.	4 5/8"	0.927" I.D.	8 1/4"
No.1884	Use on Alpha 1999-05 FXD or Alpha 1999-06 FL.	4 5/8"	0.927" I.D.	8 1/4"

### TWIN CAM® BETA STROKER FLYWHEEL ASSEMBLIES (WITHOUT PISTONS)

PART NO.	APPLICATION	STROKE	WRIST PIN BUSHING	FLYWHEEL DIA.
No.1886	Use on Beta Softail® 2000-06	4 1/2"	0.927" I.D.	8 1/4"
No.1888	Use on Beta Softail® 2000-06	4 5/8"	0.927" I.D.	8 1/4"

# TWIN CAM RODS & CRANK PIN WELD SERVICE

2

Solid Bronze Bushing for .927 wrist pin  
Also Available on Page 89



## JIMS® CONNECTING RODS

PRODUCED FROM FORGED  
4340 AEROSPACE QUALITY STEEL

JIMS® Connecting Rods start out as forged aerospace quality 4340 Chromoly steel blanks, then the rods are CNC machined on our high tech mills. Each rod is heat treated, magnafluxed and shot peened, then inspected. From there, each rod goes back into the CNC mill to bore both the rod race and wrist pin bushing bores to within .0003" of each other. A 32 bore finish is achieved for the best possible bushing and race adhesion. The wrist pin bushing oiling hole has been optimized for utilizing lubrication of wrist pins, and an increase in the strength. JIMS® chooses "H-Beam" rods for stability and

strength, for both drag racing and any street application, over the standard "I-beam" rods. Although we realize that "H-beam" rods are very difficult and time consuming to manufacture, JIMS® believes that it is well worth the extra effort. Each rod set has JIMS® wrist pin bushings installed and are sized for .927" pins. Rod race to be sized by engine builder. JIMS® "H-beam" rods are available in two different lengths of centerline dimensions that are: 7.667" or 7.600". Rod races must be finished sized. *For more details see No.4015-IS instructions.*

No.4017 - Use on Twin Cam®, 7.600" length.

No.4015 - Use on Twin Cam®, 7.667" length.

## JIMS® RACE WELD FLYWHEEL SERVICE

Squeezing all the horsepower out of your Twin Cam® is relatively easy to do as JIMS® and other reliable performance companies have been perfecting it for years. Getting all that power to the pavement is "sometimes" a completely different story. This is just one of the reason's JIMS® has built a track record for one of the strongest lower end assemblies available (flywheels, crankpins, nuts and connecting rods). Taking it one step further, we now offer a Race Proven flywheel adherence service - RACE WELD. We all know a stock clutch and or other components will not live for long periods of time in extreme high horsepower racing conditions, that is,

if you can get the power to the track (controlled traction).

For this same reason, JIMS® uses the latest developments in: aerospace steel, state of the art machining, heat-treating and precision assembly to create one of the industries strongest lower ends (The JIMS® Flywheel Assembly). For some engine's, experienced racers and extreme riders will benefit from using this new flywheel adhering technique (welding). So for you racers out there

(you know who you are) that are looking for the flywheel assembly that can hold up under extreme conditions - look to JIMS® new RACE WELD service. All welding is done after flywheels have been precision assembled and trued. Each assembly is held in such a way that no arcing of bearings can take place. The entire assembly is covered in a way that the only open area is the four places that are welded. In doing this, we eliminate any chance of foreign material contaminating the assembly. For the ultimate in flywheel retention, choose the JIMS® new RACE WELD Service.



No.1880 - Available service for use on JIMS® new assembled flywheels only.



## PRESSED EVO STROKER KITS CARBURETOR ONLY

Unmatched strength for your EVO! Your next high performance EVO engine build will be more reliable with JIMS® new EVO/Twin Cam® hybrid crank assembly. We have integrated the strength and stiffness of the genuine Harley® Twin Cam® crank pin and bearings into our new Evo crankshaft assembly. Each left flywheel and shaft is forged as a unit to maximize stiffness and reliability. Of course, we use the proven JIMS® "H" beam 4340 chromoly connecting rods for the ultimate in strength and stability. This is the strongest and most rigid EVO crankshaft made.

The bolt together EVO crankshaft has some limits when run at high rpm in powerful engines. The taper-fit crank pin flexes at high rpm and can often shift, even in normal use. Harley choose to enlarge the pin diameter and make it a press fit in flywheels of the Twin Cam® engine. This greater rigidity and load capacity is perhaps the greatest advantage of the Twin Cam® engine over the EVO. JIMS® new EVO crankshaft goes a long way to narrow the difference in strength between the two engines.

These kits are shipped with standard length sprocket and pinion shafts. These kits can be installed into 1984-99 cases with standard pinion shaft races (24599-58B, 24599-58A, etc.). 24628-87 pinion bearings may also be used.

For 3-5/8" bore pistons, motor cases will have to be bored to install 3-5/8" cylinders. See JIMS® Evo case bore tool No.1409 on page 168.

For 1990-99 motors, use JIMS® pinion gear No.24043-78, JIMS® oil pump drive gear No.26349-84 (with JIMS® Keys 2480K), and JIMS® Nut 24023-54.

• Parts not available separately, except piston sets.

For more details see No.1972-IS instructions



## 80" EVOLUTION® STROKER KITS WITH DOMED PISTONS

PART NO.	APPLICATION	STROKE	BORE	FLYWHEEL DIA.	COMPRESSION RATIO
No.1976	Use on EVO 1984-present	4 1/4"	3 1/2" STD	8 1/2"	*10:1
No.1977	Use on EVO 1984-present	4 1/4"	3 1/2" +.005	8 1/2"	*10:1
No.1978	Use on EVO 1984-present	4 1/4"	3 1/2" +.010	8 1/2"	*10:1

\*Compression Ratio Approximate

## 87" EVOLUTION® STROKER KITS WITH FLAT TOP PISTONS

PART NO.	APPLICATION	STROKE	BORE	FLYWHEEL DIA.	COMPRESSION RATIO
No.1979	Use on EVO 1984-present	4 1/2"	3 1/2" STD	8 1/2"	*10:1
No.1980	Use on EVO 1984-present	4 1/2"	3 1/2" +.005	8 1/2"	*10:1
No.1981	Use on EVO 1984-present	4 1/2"	3 1/2" +.010	8 1/2"	*10:1

\*Compression Ratio Approximate

## 89" EVOLUTION® STROKER KITS WITH FLAT TOP PISTONS

PART NO.	APPLICATION	STROKE	BORE	FLYWHEEL DIA.	COMPRESSION RATIO
No.1982	Use on EVO 1984-present	4 5/8"	3 1/2" STD	8 1/2"	*9.25:1
No.1983	Use on EVO 1984-present	4 5/8"	3 1/2" +.005	8 1/2"	*9.25:1
No.1984	Use on EVO 1984-present	4 5/8"	3 1/2" +.010	8 1/2"	*9.25:1

\*Compression Ratio Approximate

## 96" EVOLUTION® STROKER KITS WITH FLAT TOP PISTONS (SEE JIMS® CASE BORING TOOL NO.1409)

PART NO.	APPLICATION	STROKE	BORE	FLYWHEEL DIA.	COMPRESSION RATIO
No.1985	Use on EVO 1984-present	4 5/8"	3 5/8" STD	8 1/2"	*9.75:1
No.1986	Use on EVO 1984-present	4 5/8"	3 5/8" +.005	8 1/2"	*9.75:1
No.1987	Use on EVO 1984-present	4 5/8"	3 5/8" +.010	8 1/2"	*9.75:1

\*Compression Ratio Approximate

## PRESSED EVO STROKER FLYWHEEL ASSEMBLIES ONLY CARBURETOR ONLY

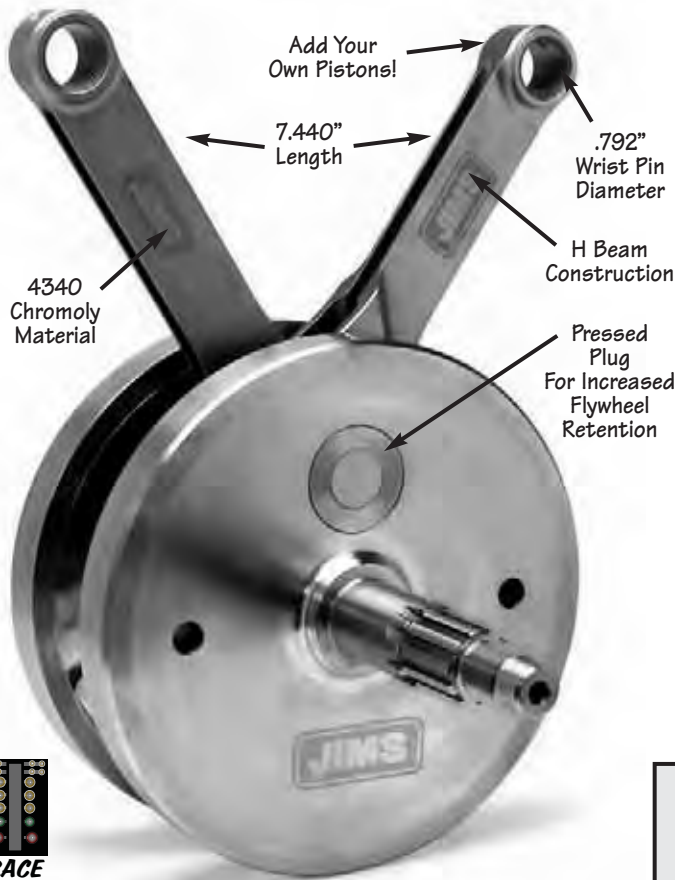

These flywheel assemblies are the same assemblies used in the JIMS® EVO press series stroker kits but without pistons. When considering your pistons, use the piston chart below to arrive at the desired balance factor for use without modifying the flywheel assembly. Anything out of the chart's range will need to be balanced by an experienced engine builder. Please note, the below weights are based on the entire piston assembly including pistons, wristpins, circlips and rings. For use on pre 1973 use a piston designed for a 7.440" rod. These kits are shipped with standard length sprocket and pinion shafts. These kits can be installed into 1984-99 cases with standard pinion shaft races (No.24599-58B, No.24599-58A, etc.). Pinion bearings No.24628-87 may also be used.

For 3-5/8" bore pistons, motor cases will have to be bored to install 3-5/8" cylinders. Use tool #1409, see pg.168.

For 1990-99 motors, use JIMS® Pinion Gear No.24043-78, JIMS® oil pump drive gear No.26349-84 (with JIMS® Key No.2480K), and JIMS® Nut No.24023-54.

• Parts not available separately.

For more details see No.1972-IS instructions



**1.671" CRANK  
PIN & STOCK ROD  
ROLLERS INCREASE  
RIGIDITY AND LOAD  
CAPACITY.**

### PISTON BALANCE FACTORS FOR JIMS® STROKERS

Below is a list of total piston weights. Example: (906 grams to 938 grams is the weight of two pistons, two sets of rings, two wrist pins and two wrist pin clips.) If the total weight of the pistons you are supplying, weigh from (906 to 938 grams) they can be used with any of the three flywheel assemblies listed below to give you a balance factor of approximately 60%. An approximate 60% balance factor is best suited for higher RPM riding (shifting at a higher RPM) or a lower gear ratio. An approximate 52% balance factor is best suited for a little less RPM riding, or a little higher gear ratio.

- 60%** To maintain a balance factor of 60% both pistons with rings, pins, and clips should weigh between 906 grams and 938 grams.
- 56%** To maintain a balance factor of 56% both pistons with rings, pins, and clips should weigh between 1021 grams and 1051 grams.
- 52%** To maintain a balance factor of 52% both pistons with rings, pins, and clips should weigh between 1136 grams and 1166 grams.

### 4 1/4" BIG TWIN STROKER FLYWHEEL ASSEMBLIES (WITHOUT PISTONS)

PART NO.	APPLICATION	STROKE	WRIST PIN BUSHING	FLYWHEEL DIA.
No.1972	Use on Shovelhead 1970-84	4 1/4"	0.792" I.D.	8 1/2"
	Use on EVO 1984-1999	4 1/4"	0.792" I.D.	8 1/2"

### 4 1/2" BIG TWIN STROKER FLYWHEEL ASSEMBLIES (WITHOUT PISTONS)

PART NO.	APPLICATION	STROKE	WRIST PIN BUSHING	FLYWHEEL DIA.
No.1973	Use on Shovelhead 1970-84	4 1/2"	0.792" I.D.	8 1/2"
	Use on EVO 1984-1999	4 1/2"	0.792" I.D.	8 1/2"

### 4 5/8" BIG TWIN STROKER FLYWHEEL ASSEMBLIES (WITHOUT PISTONS)

PART NO.	APPLICATION	STROKE	WRIST PIN BUSHING	FLYWHEEL DIA.
No.1974	Use on Shovelhead 1970-84	4 5/8"	0.792" I.D.	8 1/2"
	Use on EVO 1984-1999	4 5/8"	0.792" I.D.	8 1/2"



OUR RESPECT & CONGRATULATIONS TO SOME LOYAL & COMMITTED LAND SPEED RACERS!



**JODY PEREWITZ:**

Jody Perewitz and Team J'Witz have exploded into the record books setting a new land speed record in her rookie season at the Bonneville Salt Flats in 2011. Jody is currently the fastest woman to ever ride an American V-Twin powered motorcycle over 200mph! Jody currently holds 4 land speed records and is looking for more. Her #264 machine is powered by a super strong 100ci V-Twin, boasting cylinders, a flywheel and engine cases from JIMS to help this supercharged power plant produce over 230 hp! You can follow Jody on Facebook!

**TR REISER (TMAN):**

Tom "T.R." Reiser, owner and operator of T-Man Performance, has been tearing across the salt for many years. In 2010, with a JIMS Fat 5-Speed Overdrive Transmission freshly installed, he snagged the World's Fastest Bagger title at the BUB Speed Trials in Utah with an 183.1mph run! T-Man Performance and JIMS have built a strong relationship through our racing experiences and we



are extremely proud to be a part of his team's continued success. Follow T-Man Performance on Facebook!

**JIMMY PAULGAARD:**

Jimmy Paulgaard, from Goldhammer Racing, has been going to the BUB event at the Bonneville Salt Flats for 4 years now. In 2010, Jimmy blew up his engine and looked to be out of the event when JIMS racer, Hiro Koiso, offered up his JIMS 131" Race Engine. Not only did Hiro, arm sling and all, help both crews with the engine switch; Jimmy fired that JIMS engine up



to reset multiple records himself. It was really an amazing situation, Jimmy finished his event with flying colors and Hiro kept his sponsors in the spotlight even with a broken bone. Watch for Jimmy to join the 200mph club this year!

**HIRO KOISO:**

Hiro Koiso is an expert engine builder and performance specialist for a Harley-Davidson dealer. He is also a multiple AMA National and FIM World Land Speed records holder! According to Hiro, making record-breaking horsepower is one thing, but making an engine last is another story. Hiro Koiso Racing and JIMS became partners in 2010, because JIMS components are essential to the treacherous racing at Bonneville for both performance and durability. You can also follow Hiro on Facebook!



**BILL FRANNEY:**

Bill Franey, racing for Salt Wheels Racing, is now in his 6th year of land speed racing. Bill has been blasting on a motorcycle for much of his life, and even used to drag race on dry lakebeds back in the 80's! His crew just finished building this new land speed bike, fully equipped with a JIMS Fat 5-Speed Overdrive Transmission, because it is the toughest, strongest gearbox on the V-Twin market. Cheer Bill on in 2012 as he attempts to break 180mph and set the record in his class!



PHOTO CREDIT SCOOTER GRUBB

## REQUIRED COMPONENTS FOR "ALPHA" & "BETA" STROKER KITS

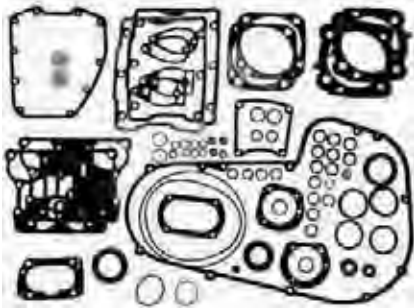

Stroker Kits **DO NOT** include gaskets. Please refer to recommended Part No. when ordering your new JIMS® gasket kit.

### GASKET KITS FOR JIMS® TWIN CAM® STROKER KITS

Complete engine and primary gasket kits for JIMS® 4" bore 113" & 116" Stroker Kits, & 100" Big Bore Kits. Includes .040" Head Gasket, .020" Base Gasket.

- No.871 - 2007-present FL'S. (4" Bore)
  - No.872 - 2007-present FXST. (4" Bore)
  - No.870 - 2006-present Dyna. (4" Bore)
  - No.858 - 2000-06 Softail & 1999-05 Dyna. (4" Bore)
  - No.859 - 1999-06 FL Models. (4" Bore)
  - No.857 - 4" Head & Base gasket kit only.
  - No.873 - 4.125" Head & Base gasket kit only.
- Note:** Base gasket is not an o-ring style gasket.

## ELECTRONIC FUEL INJECTED MANIFOLD SPACER KITS



**(Head to Manifold Spacer)** Use with Stroker Kits when fitting standard width manifolds and using taller cylinders. Also use with JIMS® 113" or 116" Stroker's using +0.100" taller cylinders. Spacers kits will increase the distance (wider) between the heads by 0.080", allows the use of standard width manifolds such as the standard Harley® EFI, Screamin' Eagle®, S&S® or other stock width manifolds having standard size intake ports. *For more details see No.721-IS instructions.*

- No.720 - Use on all 2006-pres. Twin Cam® models, having a intake port size of 1.80".
- No.725 - Use on all stock Big Twins manifolds, 1990-Pres. (NON-CVO's) having a intake port size of 1.640".
-  No.721 - Use on all 2006-pres. Twin Cam® models, having a intake port size of 1.640" to 1.740".

## EXTENDED MANIFOLD & FLANGES ACCESSORIES



113" or 116" stroker kits require a special extended manifold. JIMS® recommends using a Mikuni® carburetor. However, you can use a stock CV, Screamin' Eagle® CV, or an S&S® "G" carburetor.

**NOTE:** These manifolds are designed to fit on heads with a 1.640" intake port size only.

### CARBURETED

- No.700 - **(Manifold)** Use with Mikuni® Carburetor, Stock CV Carburetor, or Screamin' Eagle CV Carburetor. (Use with No.703 or No.701)
- No.702 - **(Manifold)** Use with S&S Super "G" Carburetor. Includes aluminum spacer. Customer must use his bakelite spacer
- No.703 - **(Flange)** for use with Part No.700 40mm CV, or a 42mm Mikuni.
- No.701 - **(Flange)** for use with Part No.700 44mm CV, or a 45mm Mikuni.





## JIMS TOP CENTER CASE BOLT AND SPOT FACER TOOL

Added insurance when building a big bore Twin Cam™ engine. Have you seen a center right case bolt thread that has become compromised from a larger cylinder spigot bore diameter? Now you can get back all the necessary case bolt retention by installing one of JIMS Through Bolt Kits No.1457. This tool is needed to spot face the right case so the bolt head will seat flat on the case surface. *For more details see No.1458-IS instructions.*

Use on All Twin Cam™ 1999 to present.

No.1458 - Case Bolt Spot Facer Tool.

No.1457 - Center Through Bolt Kit.



### 10mm COMPRESSION RELEASE VALVES

These release valves make starting your engine effortless by venting cylinder compression with just the push of a button. JIMS® has found these to be indispensable when used with JIMS® Stroker Kits. Simply drill and tap each cylinder head and thread in the self-sealing release valves. *For more details see No.727K-IS instructions.*

No.727K - Use on all Big Twin, Sportsters and Buells.

**NOTE:** Install JIMS® Compression Release Valves with JIMS® Installation Tool No.1169 for Twin Cam®, or use JIMS® Tapping Tool No.1169-1 for all other engines. See page 144.

## STROKER PISTON OILING JET KIT



JIMS® Twin Cam® piston oiling jets are designed with an additional .150" clearance compared to

stock OEM jets. For use on longer stroked engines, always check clearances during assembly. *For more details see No.1905-IS instructions.*

No.1905 - Use on all performance Twin Cam® engines H-D® and JIMS® 1999-present.



## TWIN CAM® TIMKEN® CASE BEARING CONVERSION TOOL

When increasing to a larger bore size and stroke, JIMS highly recommends for 2003 to present Twin Cam models you convert the left crankcase bearing to the more durable H-D® No. 9028 Timken® bearing, using JIMS Timken conversion tool No.959. *For more details see No.959-IS instructions.* See page 133.

No.959 - Use on Twin Cam® engines 2003-present. Order Timken® bearings separately. For replacement insert sleeves see No.956.



## CASE BORING TOOLS

The new JIMS® case boring tool takes all the guess work out of boring T/C motor cases will accept JIMS® 4" bore cylinders, for the JIMS® 100" Big Bore kits, 113" and 116" F/W cylinder kits. This tool is designed to be used in a heavy duty 15" drill press. *For more details see No.1177-IS instructions.* See page 168.

No.1408 - Use on all Twin Cam® models, A or B, 1999-present.

No.1409 - Use on EVO, Big Twin 1984-99.

# DAYTONA TWIN TEC IGNITION MODULES



## PLUG IN 12 PIN IGNITION MODULE

These carbureted Daytona Twin Tec adjustable module's, features are:

- \* • Wide timing advance adjustment range that accommodates stock to highly modified engines.
- Digitally set RPM limit (steps from 3,000 to 9,900 RPM).
- Full support for J1850 data bus used for communications with instrument cluster and turn signal / security module (TSM/TSSM).
- Compatible with aftermarket tachometers.
- Built – in data logging. Stores last 30 minutes of engine operation.
- Extensive diagnostics and compatibility with H-D scan tool.
- Optional UBS interface and software for custom programming and data analysis.
- Billet housing with a 12 pin connector.
- Easy plug in installation with instructions.

No. 2228 - Use on carbureted 2003-2006 Twin Cam and Sportster. Also for 2004-2007 American Iron Horse motorcycles.



## USB CABLE INTERFACE

- \* This accessory interfaces with all Daytona Twin Tech engine ignition controls. Windows compatible software allows the UPC to program a custom advance curve for precise dyno tuning. Includes all required adapters for Models 1005 - 1007, TC88, TC88A ignitions, and TCFI/VRF1 fuel injection systems.

No. 2231 - Use on JIMS No. 2228, 2229, or 2230 modules and TCFI/VRF1 fuel injection systems.



## PLUG IN DUEL 6 PIN IGNITION MODULE

These carbureted Daytona Twin Tec adjustable module's, features are:

- \* • Wide range of timing advance adjustment that accommodates stock to highly modified engines.
- Digitally set RPM limit (100 RPM steps).
- Selectable multi – spark mode for quick starting and smooth cruise.
- Coil outputs protected against short circuits.
- Optional UBS interface and software for programming custom advance curve.
- Billet housing with a 12 pin connector.
- Supports all sensors including theft/security module.
- Easy plug in installation with instructions.

No. 2229 - Use on 1999 -2003 carbureted Twin Cam models.



## EXTERNAL PLUG IGNITION MODULE

These carbureted Daytona Twin Tec adjustable module's, features are:

- \* • Wide range timing advance adjustment accommodates stock to highly modified engines.
- Digitally set RPM limit (100 RPM steps).
- Selectable multi – spark mode for quick starting and smooth cruise.
- Coil outputs protected against short circuits.
- Optional UBS interface and software for programming custom advance curve.
- Billet housing with a 8 pin connector.
- Easy plug in installation with instructions.

No. 2230 - Use on 1994 - 1999 later Evolution Big Twins.

\* Note: For any technical support on the modules contact: Daytona Twin Tech 1-386-304-0700.



## REPLACEMENT FORGED ALUMINUM PISTON

JIMS® pistons represent an advancement in piston design and function. These pistons now incorporate the latest oil control technology with 3mm oiling control ring grooves, and advanced piston skirt design. By reducing the oil control ring to a 3mm thickness there is less internal friction, which reduces heat, and creates more power. The piston skirts have also been optimized to take full advantage of piston support without incurring more friction. The rear piston's, non thrust face portion, receives a radial notch to clear the full skirt of the front piston. This design gives the front piston more support while still allowing proper piston-to-piston clearance. Replacement pistons retain original design piston notching.

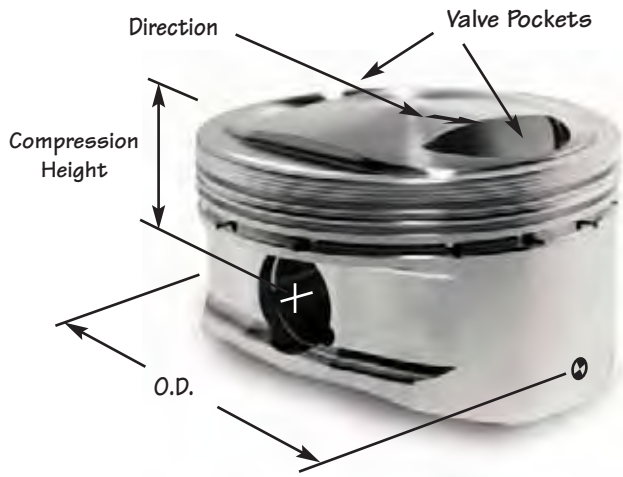

### COMPRESSION HEIGHT CLEARANCE

The compression height (C.H.) is measured from the centerline of the wrist pin to the piston deck (the top outer most edge of the piston w/out dome). A minimum piston-to-head clearance of .040" should be maintained when using steel connection rods. To determine this clearance, combine the compression height with a compressed cylinder base gasket's thickness.

### VALVE POCKET DEPTH

Though dependent on several factors, JIMS® recommends that valve pocket clearance be kept to a .060" clearance for both intake and exhaust valves. **Note:** Always check valve clearance with clay and fully solid tappets before turning engine over.

### COMPRESSION RATIOS

Unless otherwise specified, all compression ratios are based on stock heads, cylinder, and stroke. Refer to your equipment manufacturer's literature for specifications.

## TWIN CAM® PISTONS



JIMS® Twin Cam® piston sets are CNC machined from aerospace quality, forged 2618 aluminum alloy. Each kit includes directional pistons, precision ground wrist pins, rings, and clips. For more details see No.1606-IS instructions.

### TWIN CAM® BIG BORE FLAT TOP PISTONS BIG BORE TWIN CAM® 100" SERIES II

Use on 1999-present. Requires 4" bore cylinders and boring of case.

PART NO.	BORE	STROKE	PIN O.D.	RINGS	C/R
No.1603	4" std	4"	.927"	No.1491	9.56:1*

\*Compression ratios are approximate.

### TWIN CAM® DISHED STROKER PISTONS STROKER TWIN CAM® 113" & 116" SERIES I

Requires JIMS® 4.5" or 4.625" Twin Cam® Stroker Kit Assemblies

PART NO.	BORE	STROKE	PIN O.D.	RINGS	C/R
No.1620	4"+.005	4.5/4.625	.827"	No.1428	10.19:1*

\*Compression ratios are approximate.

### STROKER TWIN CAM® DISHED 113" SERIES II

Requires JIMS® 4.5" Twin Cam® Stroker Kit Assemblies

PART NO.	BORE	STROKE	PIN O.D.	RINGS	C/R
No.1607	4" std	4.5/4.625	.927"	No.1491	10.19:1**
No.1607B	4"+.010	4.5/4.625	.927"	No.1493	10.19:1**

\*Compression ratios are approximate.

### STROKER TWIN CAM® DISHED 116" SERIES II

Requires JIMS® 4.625" Twin Cam® Stroker Kit Assemblies

PART NO.	BORE	STROKE	PIN O.D.	RINGS	C/R
No.1608	4" std	4.5/4.625	.927"	No.1491	10.19:1**
No.1608A	4"+.005	4.5/4.625	.927"	No.1492	10.19:1**
No.1608B	4"+.010	4.5/4.625	.927"	No.1493	10.19:1**

### TWIN CAM® WRIST PIN CLIP SETS

No.1602K - Replacement wrist pin clips for .827" wrist pins.

Use on JIMS® Series I 100" piston set No.1620.

No.1604K - Replacement wrist pin clips for .927" wrist pins.

Use on piston set No's. 1603, 1607, 1607B, 1608, 1608A and 1608B.

\*\*Compression ratios based on 85.9cc head with .040" head gasket and 9.5cc piston dish at zero deck height.

\*Compression ratios are approximate.

TWIN CAM® PISTON SPECS.		
	COMPRESSION HEIGHT	COMPLETE WEIGHT
1603	1.270"	1148g
1620	1.125"	1058g
1607	1.188"	1140g
1607B	1.188"	1142g
1608	1.125"	1115g
1608A	1.125"	1116g
1608B	1.125"	1118g

TWIN CAM® PISTON SPECS.		
	COMPRESSION HEIGHT	COMPLETE WEIGHT
1611	1.199"	1145g
1613	1.199"	1149g
1614	1.27"	1171g
1615	1.175"	1149g
1616	1.0825"	1148g
1617	1.125"	1143g
1618	1.125"	1145g

## EVOLUTION® PISTONS



JIMS® forged 2618 aluminum pistons add unquestioned reliability to stock and performance Evolution® engines. Each set includes pistons, rings, wrist pins, and wrist pin clips. The 106" kit is listed as *While Supplies Last*, please call in for special reduced pricing.

For more details see No.1530-IS instructions.

Recommended JIMS® Tools for Piston, Rings and Wrist Pins, Wrist Pin Clips, and Wrist Pin Bushings:

### Twin Cam®

- No.951 - Torque Plates
- No.1051 - Connecting Rod Bushing Tool
- No.1726-3 - Wrist Pin Bushing Reamer Tool
- No.1276 - Wrist Pin Remover & Installer Tool
- No.1235 - Piston Ring Expander Tool
- No.1236 - Piston Ring Compressor Tool
- No.1765 - Piston Ring Groove Cleaner Tool
- No.1284 - Rod Holder Tool
- No.1164 - Piston Support Plate Tool
- No.1148 - Rod Alignment Tool

### EVO 80" DOMED PISTONS

PART NO.	BORE	STROKE	PIN O.D.	RINGS	C/R	COMP. HEIGHT	TOTAL PISTON SET WEIGHT
No.1555	3.5" STD.	4.25"	.792"	No.1461	10:1	1.375"	924g
No.1555A	3.5"+.005	4.25"	.792"	No.1462	10:1	1.375"	928g
No.1555B	3.5"+.010	4.25"	.792"	No.1463	10:1	1.375"	931g

### EVO 87" FLAT TOP PISTONS

PART NO.	BORE	STROKE	PIN O.D.	RINGS	C/R	COMP. HEIGHT	TOTAL PISTON SET WEIGHT
No.1558	3.5" STD.	4.50"	.792"	No.1461	10:1	1.250"	898g
No.1558A	3.5"+.005	4.50"	.792"	No.1462	10:1	1.250"	902g
No.1558B	3.5"+.010	4.50"	.792"	No.1463	10:1	1.250"	908g

### EVO 89" FLAT TOP PISTONS

PART NO.	BORE	STROKE	PIN O.D.	RINGS	C/R	COMP. HEIGHT	TOTAL PISTON SET WEIGHT
No.1561	3.5" STD.	4.625"	.792"	No.1461	9.25:1	1.188"	882g
No.1561A	3.5"+.005	4.625"	.792"	No.1462	9.25:1	1.188"	887g
No.1561B	3.5"+.010	4.625"	.792"	No.1463	9.25:1	1.188"	906g

### EVO 96" FLAT TOP PISTONS

PART NO.	BORE	STROKE	PIN O.D.	RINGS	C/R	COMP. HEIGHT	TOTAL PISTON SET WEIGHT
No.1576	3.625" STD.	4.625"	.792"	No.1467	9.75:1	1.200"	898g
No.1576A	3.625"+.005	4.625"	.792"	No.1468	9.75:1	1.200"	942g
No.1576B	3.625"+.010	4.625"	.792"	No.1469	9.75:1	1.200"	947g

WHILE SUPPLIES LAST

### EVO 106" FLAT TOP PISTONS

PART NO.	BORE	STROKE	PIN O.D.	RINGS	C/R	COMP. HEIGHT	TOTAL PISTON SET WEIGHT
No.1584	3.812" STD.	4.625"	.792"	No.1475	10:1	1.200"	1036g
No.1584B	3.812"+.010	4.625"	.792"	No.1477	10:1	1.200"	1033g

### EVO WRIST PIN CLIP SETS

- No.1599K - Replacement wrist pin clips, 4-pack for all piston sets below.

### EVOLUTION

- No.1073 - Torque Plates
- No.1726-1 - Wrist Pin Bushing Reamer Tool
- No.1235 - Piston Ring Expander Tool
- No.1236 - Piston Ring Compressor Tool
- No.34623-83 - Piston Pin Keeper Tool
- No.1172 - Wrist Pin Clip Remover & Installer Tool
- No.1765 - Piston Ring Groove Cleaner Tool
- No.1284 - Rod Holder Tool
- No.1164 - Piston Support Plate Tool
- No.1010 - Rod Alignment Tool

Refer to the "Tool Section" of catalog for more details.



# ROCKER ARMS

## JIMS® STREET OR STRIP PERFORMANCE QUALITY ROLLER ROCKER ARMS



Here at JIMS® we're always researching and developing ways to improve existing product, as in our roller rocker arms. JIMS® Roller Rocker Arms are made from aerospace quality 4340 steel. This is the "King" of the hardening grade of constructional alloy steels. Due to a richer alloy content, 4340 possesses much deeper concentration of hardening than the 4100 series. This advantage is realized principally where high strength is required in heavy sections. In addition, an unusually high concentration of hardening ensures maximum toughness and ductility at the desired strength level. The fatigue-tensile ratio makes this grade of alloy steel ideal for highly stressed parts. It maintains its strength, ductility, and toughness at relatively high temperatures. It has remarkable non-distorting properties for an alloy steel, with an overall increase in strength and a decrease of flex. We machine the rockers on the newest horizontal CNC mills available. The new rockers are heat treated and assembled with JIMS® 660 Bronze Bushing, bearing steel roller and axle. The combination of these high quality materials along with our precision machining standards result in the best roller rocker arms available.

### Why Buy a JIMS® Roller Rocker Arm?

- *Produced from aerospace quality 4340 chromoly steel*
- *Features a segmented parabolic pushrod cup, which reduces friction at pushrod end and also puts the load on the outer perimeter of pushrod ends*
- *Features full oiling of the roller tip, valve springs and pushrod tip*
- *52100 bearing steel roller tip for the longest possible life*
- *660 bronze bushing for the best wear resistance and oil control, fit to H-D® specifications*
- *Reduces friction, heat, and wear in all valve train components from stock to strip*
- *Heat treated by JIMS® special technique to provide you with the strongest and lightest roller rocker arms*
- *A true 1.625 rocker arm ratio, with improved rocker geometry*
- *Quieter, smoother valve train...The JIMS® Way!*

# ROCKER ARMS



## ROCKER ARM SET - 1.745 RATIO

### ROLLER ROCKERS - STOCK RATIO 1.625

The best just got a whole lot better!...JIMS® Roller Rockers are designed to reduce friction in the valve train and provide more horsepower with less heat in the top end. Cast from 4340 chromoly steel and heat treated, JIMS® Roller Rockers feature a 660 bronze bushing fit to .0007"-.0012", for the best wear resistance and oil control, along with a roller tip made from bearing grade material which reduces valve guide wear and valve tip galling. Other features include a segmented parabolic pushrod cup which reduces friction at pushrod ends and also puts the load on the outer perimeter of pushrod ends. Designed to work in conjunction with other JIMS® valve train components. Use JIMS® No.17611-83 Rocker Arm Shafts, or equivalent. These Rocker Arms replace H-D® No's 17360-83A & 17375-83A. For more details see No.1045-IS instructions.

**NOTE:** Twin Cam® rocker boxes require clearing of the webbing on the valve side.

No.1045RR - Use on all Big Twin 1984-present and aftermarket engines.  
Use on Sportster® 1986-present.  
Use on Buell® 1987-present, except 1125R.

JIMS® Roller Rocker Arms in a 1.745 rocker ratio. Made with the same high standards as JIMS® 1.625 stock ratio roller rockers. JIMS® 1.745 ratio rockers are designed to work with JIMS® other valve train components and function with JIMS® total valve train system. Cast from 4340 chromoly and then heat treated for maximum strength. Designed to be used with JIMS® No.17611-83 Rocker Arm Shafts or equivalent. For a custom valve train set up where a super high lift is required, using a small lift cam, this 1.745 ratio rocker allows the engine builder to achieve more lift at the valve. For more details see No.1731-IS instructions.

**NOTE:** These rockers are not a bolt-in roller rocker. They are designed to be installed by the most advanced engine builder. Modification to the heads and rocker boxes may be necessary to install these rockers.

No.1731 - Use on Big Twin 1984-present and aftermarket engines.  
Use on Sportster® 1986-present.  
Use on Buell® 1987-present, except 1125R.

**NOTE:** Engine builder still has the responsibility of checking and confirming the operating clearance when installing any of JIMS® products.

### SHOVELHEAD ROLLER ROCKERS - RATIO 1.50

Complete Valve Train Kit on Page 65



By popular demand, JIMS® introduces Roller Rocker Arms for Shovelheads (cast from 4340 chromoly steel and heat treated.) Designed to reduce friction in the valve train, providing more horsepower and less heat in the top end. JIMS® Roller Rockers feature a 660 bronze bushing fit to .0007" - .0012" for the best wear resistance and oil control, along with a roller tip made from bearing grade material to reduce valve guide wear and valve tip galling. Other features include a segmented parabolic pushrod cup which reduces friction at pushrod ends

and also puts the load on the outer perimeter of pushrod ends, with full oil pressure at pushrod tip. Designed to work in conjunction with other JIMS® valve train components. Use JIMS® No.17611-66B Rocker Arm Shafts, or equivalent. These Rocker Arms replace H-D® No's 17630-66A & 17375-66A. For more details see No.1732-IS instructions.

No.1732 - Use on Big Twin 1966-1984, and aftermarket engines.



# ROCKER SHAFTS & HEADBOLTS

Precision Machined  
Tool Steel



## ROCKER SHAFT

Std. O.D. is .554". This rocker shaft replaces H-D® No.17611-83 and S & S® No.90-4006

No.17611-83 - Use on Big Twin 1984-present. (Note: Fits Twin Cam® 96" , and aftermarket engines). Use on Sportster® 1986-present. Use on Buell® 1987-present, except 1125R.



## SHOVELHEAD ROCKER SHAFT

Std. O.D. on big end is .937" , smaller end is .434". This rocker shaft replaces H-D® No.17611-66B.

No.17611-66B - Use on Big Twin 1966-84.



## IRONHEAD SPORTSTER® ROCKER SHAFT

Std. O.D. on big end is .937" , smaller end is .434". This rocker shaft replaces H-D® No.17435-57B.

No.17435-57B - Use on Sportster® 1957-85.

Race Application  
Grease Hole



## RACE APPLICATION ONLY ROCKER SHAFT

Grease hole fitting thread size is 1/4"-28.

No.17611-83H - Has grease hole in one end. Designed for race bikes using a dry top end.



## CHROME EVO OR TWIN CAM® HEADBOLT KIT

These precision manufactured headbolt sets come with a 12 point domed top. They have a 170,000 minimum PSI tensile strength and are made from an aerospace quality moly steel. They have a special heat treating process to retain maximum strength for this application. Use JIMS® tool No.2392 Headbolt Torque Gauge to assist the builder when torquing headbolts. Do not overtorque headbolts. Follow manufacturers torque specifications when installing headbolts. Set has 4 - 3 3/16" and 4 - 1 7/8" long bolts.

No.1160 - Use on 1992-present Big Twins, Twin Cam®.

Use on 1993-present Sportster® & Buell®, except 1125R.



Ray Price Racing

Manufactured  
From  
Solid Bronze



## CUSTOM ROCKER ARM BUSHING

These bushings are manufactured from solid billet bearing bronze bar stock. For repairing roller rockers that use Torrington® Roller Bearings. Remove bearing with JIMS® Tool No.95760-57. Press in new bushings using JIMS® Tool No. 2357, and line ream to H-D® specification using JIMS® Tool No.94804-57. Works in Crane® Rocker Arms with approximately .785" inside diameter. **Sold only in packs of 8.** Ream to fit. O.D. is .790".

For EVO, use JIMS® Rocker Arm Shafts No.17611-83, or equivalent. For Shovelheads, use JIMS® No.17611-66B.

No.17428-CCK - Use for custom applications.

Manufactured  
From  
Solid Bronze



## EARLY ROCKER ARM BUSHING

These bushings are manufactured from solid billet bearing bronze bar stock. I.D. .547"  $\phi$ . **Sold in packs of 8.** Ream to fit. Use JIMS® tool No.95760-57 for removal, No.2357 for installing and No. 94804-57 for reaming. This bushing replaces H-D® No. 17428-57.

No.17428-57K - Use on Big Twin 1966-84.

Use on Sportster® 1957-85.

Manufactured  
From  
Solid Bronze



## LATE MODEL ROCKER ARM BUSHING

These bushings are manufactured from solid billet bearing bronze bar stock. **Sold in packs of 8.** Same as 17428-57 – less mill slot (not to be used on Shovels or Ironhead Sportsters.) I.D. is .555". Intended for hone only. Install bushings with JIMS® Tool No.2357. I.D after press fit approx.  $\phi$ .552"-.553"

No.17428-83K - Use on all Big Twin 1984-present. (Note: Fits all Twin Cam®, and aftermarket engines). Use on Sportster®1986-present. Use on Buell®1987-present, except 1125R.

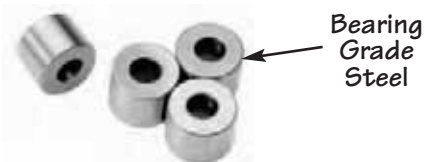

Bearing  
Grade  
Steel

## ROCKER ARM ROLLER

These rollers are manufactured from aerospace bearing steel. Use on all JIMS® Roller Rocker Arms as a replacement roller. **Sold in packs of 4.**

No.2178K - Replacement roller.



## ROCKER ARM AXLE

These rollers are manufactured from aerospace bearing steel. Use on all JIMS® Roller Rocker Arms as a replacement axle. **Sold in packs of 4.**

No.2179K - Replacement axle.



## ROCKER ARM LOCK RING

State of the art lock rings, will hold up to 2000 p.s.i. Use on all of JIMS® Roller Rocker Arms as a replacement lock ring. **Sold in packs of 8.**

No.2180K - Replacement lock ring.



## PRECISION VALVES FROM JIMS®

These valves are made from the highest grade, one piece, stainless steel and heat treated forgings. Each valve has a bearing quality hardened tip at the end of the stem to prevent premature wear with high-lift applications. This special design includes a polished 45 degree lead below the lock ring groove to prevent seal damage. Each valve is then nitrided with a special process and the stem is centerless ground to a micro finish for longer life.

## PRECISION GUIDES FROM JIMS®

Valve guides are made from both manganese bronze or Micrograin Cast Iron. Both incorporate a special high temp Viton O-ring seal. This seal will prevent any oil from passing between the guide and the head. Guides also incorporate a smooth lead in self-aligning radius for the best possible alignment during installation. The nose is also designed with a tapered guide that will give an increase in air flow.

At the top of the guide, there is a specially designed super grip finish that will keep teflon or k-line style seals in place. We have also shortened the top of the guides for high lift cams to clear all valve spring collars. With Manganese Bronze Alloy, intake guides can be fit to .0008" and exhaust guides can be fit to .0012" or more depending on application - when used with JIMS® valves only.

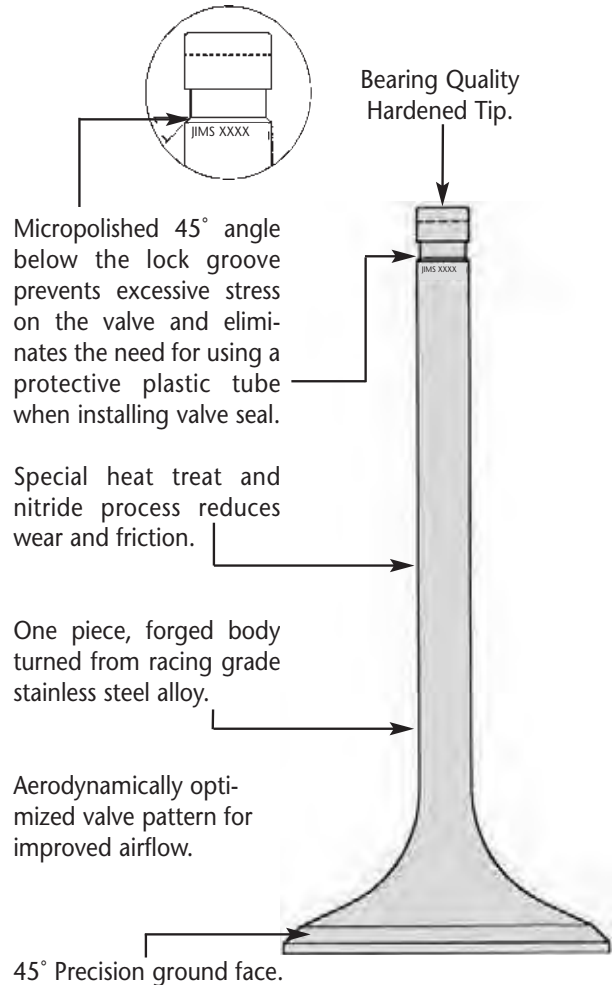
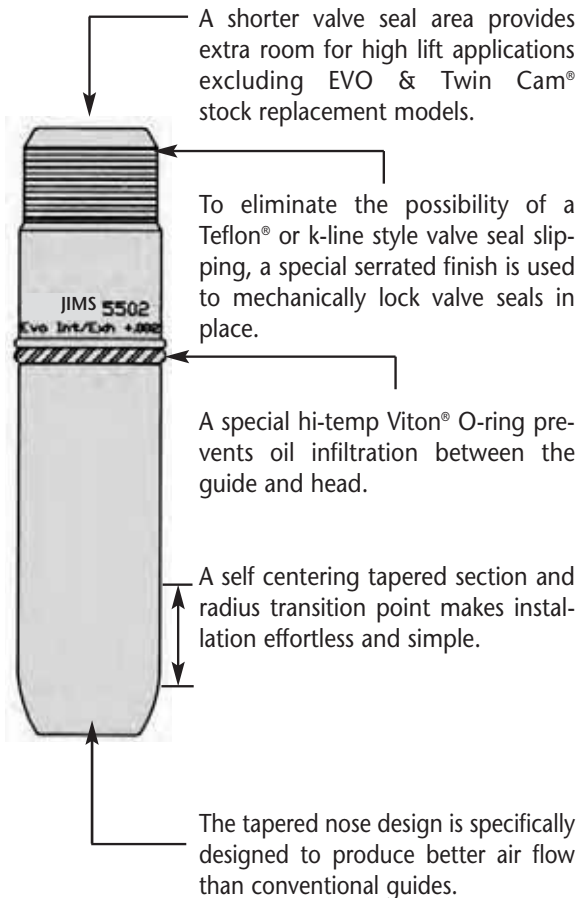
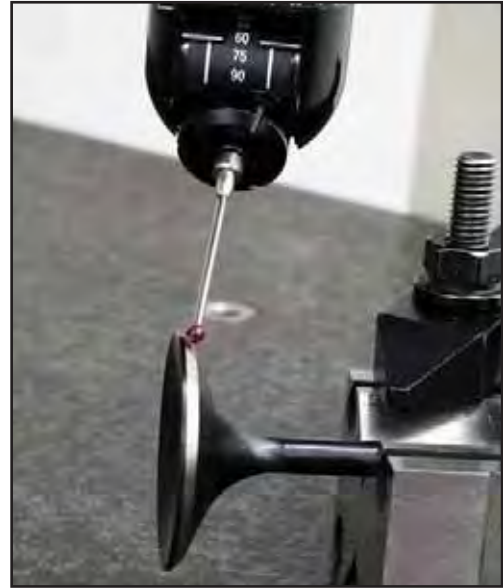

## JIMS® BLACK NITRIDE PERFORMANCE VALVES

JIMS® completes the quest for the ultimate valve train system with the addition of these high-performance valves. Designed to withstand extreme racing conditions, these valves are constructed from a forged one piece racing grade stainless steel alloy, and specially heat-treated for superior wear resistance. A special micropolished 45° angle just below the lock groove prevents excessive stress on the valve, and makes valve seal installation easier.



## TWIN CAM/EVO BLACK NITRIDE PRO VALVES

(Use on 1984-present EVO Big Twin, and 1999-04 Twin Cam® engines, and most aftermarket performance heads.)

PART NO.	VALVE TYPE	HEAD DIA.	OVERALL LENGTH	STEM DIA.	PROFILE
No.1310A	Exhaust	1.610"	4.525"	.3106"	Dished Head
No.1310B	Exhaust	1.570"	4.525"	.3106"	Dished Head
No.1311	Intake	1.900"	4.440"	.3108"	Dished Head
No.1312	Intake	1.940"	4.440"	.3108"	Dished Head
No.1313A	Intake	2.020"	4.440"	.3108"	Dished Head
No.1313	Intake	2.020"	4.490"	.3108"	Dished Head (+.050")

## EVO SPORTSTER® 883cc - 1200cc CONVERSION BLACK NITRIDE PRO VALVES

These valves are designed to convert 1986 to present EVO Sportsters 883cc - 1200cc dimensions. **NOTE:** Valve seats must be machined larger and deeper to accommodate the larger valves.

PART NO.	VALVE TYPE	HEAD DIA.	OVERALL LENGTH	STEM DIA.	PROFILE
No.1314	Exhaust	1.480"	4.640"	.3106"	Dished Head
No.1315	Intake	1.720"	4.560"	.3108"	Dished Head

## S&S® REPLACEMENT BLACK NITRIDE PRO VALVES

PART NO.	VALVE TYPE	HEAD DIA.	OVERALL LENGTH	STEM DIA.	PROFILE
No.1314S	Exhaust	1.610"	4.565"	.3106"	Dished Head
No.1315S	Intake	2.020"	4.510"	.3108"	Dished Head



# REPLACEMENT VALVES

## JIMS® HEAVY DUTY STAINLESS STEEL REPLACEMENT VALVES

These valves are heat-treated and nitride processed for excellent wear resistance. These valves feature a 45° angle, cut below the lock groove to reduce stress in this area, as well as making valve seal installation easier.



### TWIN CAM® VALVES

PART NO.	VALVE TYPE	APPLICATION	HEAD DIA.
No.1324	Intake	Use on Twin Cam® 1999-04	1.845"

### EVOLUTION® VALVES

PART NO.	VALVE TYPE	APPLICATION	HEAD DIA.
No.1323	Exhaust	Use on Evolution® Big Twin 1984-99*	1.615"
No.1324	Intake	Use on Evolution® Big Twin 1984-99*	1.845"

\*Will fit aftermarket heads using stock size OEM replacement valves.

### SHOVELHEAD VALVES

PART NO.	VALVE TYPE	APPLICATION	HEAD DIA.
No.1320	Exhaust	Use on Shovelhead 1966-84	1.750"
No.1322	Intake	Use on Shovelhead 1966-84	1.955"

### PANHEAD VALVES

PART NO.	VALVE TYPE	APPLICATION	HEAD DIA.
No.1320	Exhaust	Use on Panhead 1948-65	1.750"
No.1320	Intake	Use on Panhead 1948-65	1.750"

**NOTE:** Engine builder still has the responsibility of checking and confirming the operating clearance when installing any of JIMS® products.

# VALVE GUIDES & REAMERS

## JIMS® VALVE GUIDES



- CNC machined.
- Special hi-temp, Viton® O-ring to prevent oil infiltration between guide and head.
- Tapered and radius nose for easier installation and better intake and exhaust flow.
- Special no-slip serrated valve seal surface: use either OEM style or teflon seals.
- Unfinished I.D., ready to be honed or reamed after installation.
- Micrograin Cast Iron or Manganese Bronze. This long lasting bearing material allows you to fit the valve at a tighter clearance for better heat dissipation and longer life.

### HIGH-PERFORMANCE MANGANESE BRONZE EVO & TWIN CAM TO 2004 VALVE GUIDES

Shortened seal area and tapered for use on high lift and high flow applications  
Use with .530" valve seals.

**RACE ONLY**

INTAKE PART NO.	EXHAUST PART NO.	OVERSIZE	O.D.	I.D.
No.1326	No.1327	STD	.5625"	.309"
No.1326-1	No.1327-1	.001"	.5635"	.309"
No.1326-2	No.1327-2	.002"	.5645"	.309"
No.1326-3	No.1327-3	.003"	.5655"	.309"

**WHILE SUPPLIES LAST**

### SHOVELHEAD & PANHEAD

#### 1200cc 1948-79 VALVE GUIDES CAST IRON

Use on stock replacement applications with OEM valve seals, or may be machined for use with .530" Teflon® valve seals.

CAST IRON PART NO.	OVERSIZE	O.D.	I.D.
No.1328	STD	.566"	.375"
No.1328-1	.001"	.567"	.375"
No.1328-2	.002"	.568"	.375"
No.1328-4	.004"	.570"	.375"

## SIZING THE GUIDE, THE JIMS® WAY!



FIG.1



FIG.2



### HIGH SPEED STEEL & SOLID CARBIDE VALVE GUIDE REAMERS

These unique reamers feature a 2" long pilot for perfect alignment with the valve guide while reaming. With these reamers you can expect to ream a valve guide to exact dimensions without any taper in just a few seconds.

#### JIMS® Manganese-Bronze valve guide reaming instructions

- Install the cylinder head in a vise. Protect the cylinder head with a clean towel or rag, as pictured.
- Insert the reamer pilot in the guide and lubricate with a good quality cutting oil like K-Line Bronze Reamer Lube. (Fig.1)
- Ream at 100-200 RPM with a slow feed rate. Let the reamer do the work and do not force the reamer. (Fig.2)
- After reaming all the way through, pull the reamer out without stopping the rotation. (DO NOT reverse rotation!)
- Clean the chips off the reamer and you're ready for the next valve guide.

**NEW**

PART NO.	DIAMETER	DESCRIPTION	APPLICATIONS
No.1133	7mm	High Speed Steel	Twin Cam 2005 to present (except CVO T/C) Buell, Sportster 2004 to present.
No.1150	.3110"	Solid Carbide Reamer	Evo/ T/C /Sportster/Buell
No.1151	.3115"	Solid Carbide Reamer	Evo/ T/C /Sportster/Buell
No.1152	.3120"	Solid Carbide Reamer*	T/C 1999 to 2004 w/5/16" valve stems EVO BT and XL, 1984 to 1999
No.1153	.3410"	Solid Carbide Reamer	Evo/ T/C /Sportster/Buell
No.1154	.3772"	Solid Carbide Reamer	Pan/Shovel
No.1155	.3777"	Solid Carbide Reamer	Pan/Shovel
No.1156	.3782"	Solid Carbide Reamer	Pan/Shovel w/ JIMS Valves



# VALVE SEATS

## JIMS® VALVE SEATS

These valve seats are made from heat and wear resistant high quality steel alloy. Each seat is manufactured with a radius edge for easy installation. These seats will resist intense valve pounding and effectively dissipate heat for consistent valve sealing. These valve seats will increase in hardness during engine break-in period. See the charts below for sizes.



### EVO & TWIN CAM® OVERSIZED VALVE SEATS

(Machining required)

PART NO.	APPLICATION	VALVE TYPE	O.D.	I.D.	THICKNESS
No.1342	EVO 1340 & Twin Cam®	Exhaust	1.757"	1.410"	.430"
No.1343	EVO 1340 & Twin Cam®	Intake	2.008"	1.610"	.440"
No.1344	EVO 1340 & Twin Cam®	Intake	2.021"	1.590"	.420"

### SHOVELHEAD REPLACEMENT VALVE SEATS

(No Machining required)

PART NO.	APPLICATION	VALVE TYPE	O.D.	I.D.	THICKNESS
No.1340	Stock Replacement	Exhaust	1.944"	1.570"	.400"
No.1341	Stock Replacement	Intake	2.135"	1.750"	.400"

### SHOVELHEAD/PANHEAD OVERSIZED VALVE SEATS

(Machining required)

PART NO.	APPLICATION	VALVE TYPE	O.D.	I.D.	THICKNESS
No.1340	Panhead Engines	Exhaust	1.944"	1.570"	.400"
No.1341	Panhead Engines	Oversize Intake	2.135"	1.750"	.400"
No.1344	Shovel / Panhead 1200cc & 1340cc	Intake	2.021"	1.590"	.420"
No.1346	Shovel / Panhead 1200cc & 1340cc	Exhaust	2.163"	1.750"	.455"

### SPORTSTER® OVERSIZED VALVE SEATS

(Machining required)

PART NO.	APPLICATION	VALVE TYPE	O.D.	I.D.	THICKNESS
No.1347	Evolution® Sportster® 883 & 1100cc & 1200cc	Exhaust	1.630"	1.180"	.385"
No.1348	Evolution® Sportster® 883 & 1100cc & 1200cc	Intake	1.880"	1.439"	.410"
No.1342A	Ironhead Sportster®	Exhaust	1.757"	1.371"	.315"
No.1357	Ironhead Sportster®	Intake	2.068"	1.750"	.315"

### UNIVERSAL VALVE SEATS

(Machining required)

Part No.	Application	Valve Type	O.D.	I.D.	Thickness
No.1358S	Universal Repair Seat	Both	1.820"	1.375"	.450"

# BEEHIVE VALVE SPRING KITS



The advantages of these performance spring kits are as follows:

- Higher RPM Capability
- Increased Revving Capability and Valve Control
- No Rocker Box Clearance Issues
- Engineered to Maximize "Harmonic Resistance"
- Handles Spring Harmonics Throughout a Wide RPM Band
- Reduces Noise
- Runs Cooler

**KITS INCLUDE SPRINGS, COLLARS, RETAINERS AND KEEPERS**

## JIMS® PERFORMANCE "BEEHIVE STYLE" VALVE SPRING KITS

These "Beehive Style" Valve Spring Kits are the newest in valve spring technology for your Twin Cam® or Sportster®. These are the top choice when installing high lift cams and made from the highest quality materials available. Valve spring retainers available in either chromoly or titanium. JIMS® No.1383 or 1384 are for street applications using OEM 7mm valves, guides and H-D® No.18094-02A seals or equivalent. JIMS® No.1385 is for race applications with larger 5/16" valve stems. All component piece sets are available on 42 and 43 pages. All JIMS® springs are magnafluxed to insure quality.

PART NO.	YEAR & APPLICATION	DESCRIPTION	SPRING O.D.	I.D. CHECKING HEIGHT	PRESSURE AT OPEN HEIGHT	PRESSURE AT BIND HEIGHT	COIL BIND	RETAINERS	SPRING NO.
1383	2005 to present Twin Cam® 2004 to present Sportster® & Buell®	Good street and performance spring to .600" lift	1.095" / 1.445"	.650" / 1.00"	Lbs. 155 In. - 1.880"	Lbs. 167 In. - 1.850"	1.230"	Chromoly	#1300
1384	2005 to present Twin Cam® 2004 to present Sportster® & Buell®	Good street or race performance spring to .600" lift	1.095" / 1.445"	.650" / 1.00"	Lbs. 155 In. - 1.880"	Lbs. 166 In. - 1.850"	1.230"	Titanium	#1300
1385	2005 to present Twin Cam® 2004 to present Sportster® & Buell®	Good street or race performance spring to .690" lift	1.185" / 1.589"	.731" / 1.135"	Lbs. 179 In. - 1.190"	Lbs. 193 In. - 1.850"	1.190"	Titanium	#1301

**NOTE:** Please see the following pages for individual "Beehive Style" valve springs, retainers and locks.

**NOTE:** Use to remove and replace valves and conical valve springs. See page 145.

**NOTE:** Engine builder still has the responsibility of checking and confirming the operating clearance when installing any of JIMS® products.



## JIMS® CONICAL VALVE SPRING COMPRESSOR TOOL

Add this collar to your JIMS® valve spring compressor tool No.96600-36B to remove and replace valves and conical (Bee Hive) H-D® No.18245-02 springs, a must-have tool for safe valve work.

No.988 - Use on all '05 to present Twin Cam®, (except SE models). Use on all '04 - present XL's & Buell® Twins, except 1125R.



# VALVE SPRING KITS



## JIMS® SPRING KITS FOR EVO AND TWIN CAM 88® "A & B" MOTORS

Spring kits from JIMS® are made from the highest grade materials such as chromoly and titanium. JIMS® spring kits incorporate an interference double spring design with a damper. The damper keeps the inner and outer spring coils from locking together while controlling power robbing harmonics in the spring. JIMS® High Performance Valve Spring Kits are engineered for maximum performance in severe applications such as high compression and big inch race and street motors. Spring Kits come in a variety of ranges and include locks, retainers and spring seats, or **sold separately in sets**. Spring Kits are **sold in sets for one engine**. All JIMS® springs are magnafluxed to insure quality.

PART NO.	APPLICATION	DESCRIPTION	YEAR	O.D.	I.D. CHECKING HEIGHT	PRESSURE AT OPEN HEIGHT	PRESSURE AT BIND HEIGHT	COIL BIND	RETAINERS	SPRING NO.
1350K	Evo Big Twin Twin Cam 88®	Good street & performance spring to .600" lift	1984-04 or *HP	1.460"	.700"	Lbs.-160 In.-1.850"	Lbs.-440 In.-1.250"	1.200"	Chromoly	#1356
1351K	Evo Big Twin Twin Cam 88®	Good street & performance spring to .600" lift	1984-04 or *HP	1.460"	.700"	Lbs.-160 In.-1.850"	Lbs.-440 In.-1.250"	1.200"	Titanium	#1356
1352K	Evo Big Twin Twin Cam 88®	Super springs, excellent street & performance spring up to .675" lift	1984-04 or *HP	1.510"	.745"	Lbs.-184 In.-1.850"	Lbs.-422 In.-1.280"	1.080"	Chromoly	#1349
1353K	Evo Big Twin Twin Cam 88®	Super springs, excellent street & performance spring up to .675" lift	1984-04 or *HP	1.510"	.745"	Lbs.-184 In.-1.850"	Lbs.-422 In.-1.280"	1.080"	Titanium	#1349
1354K	Evo Big Twin Twin Cam 88®	For race applications up to .675" lift	1984-04 or *HP	1.540"	.725"	Lbs.-195 In.-1.900"	Lbs.-422 In.-1.250"	1.175"	Titanium	#1359
1355K	Evo Big Twin Twin Cam 88®	For race applications up to .700" lift	1984-04 or *HP	1.550"	.710"	Lbs.-230 In.-1.875"	Lbs.-700 In.-1.200"	1.100"	Titanium	#1360

\* May also be used on High Performance Heads

**NOTE:** Engine builder still has the responsibility of checking and confirming the operating clearance when installing any of JIMS® products.

# SPRING & SPRING SEATS



**SPRING SETS ARE SOLD IN SETS OF 4 FOR ONE ENGINE**

## PERFORMANCE VALVE SPRING SETS

A Spring is a Spring. Right? Wrong! All Springs are not equal. Valve Springs perform the job of returning the valve to its seat hundreds of thousands of times in the most severe conditions. JIMS® Springs are made from the highest grade materials, heat treated to the highest industry standards, then torture tested on the street and the track to ensure not only consistent quality, but unmatched performance as well.

JIMS Spring Kits incorporate an interference double Spring design with a damper. The damper keeps the inner and outer Spring coils from locking together, while controlling power robbing harmonics in the Spring.

PART NO.	DESCRIPTION	APPLICATION	SEAT LOAD	OPEN LOAD	COIL BIND	RATE LBS / IN
No.1356	1.460 Double Spring w/damper	1984-04 EVO/Twin Cam®**	125@1.800	275@1.300	1.150"	300
No.1359	1.540 Double Spring w/damper	1984-04 EVO/Twin Cam®**	195@1.900	515@1.250	1.175"	492
No.1360	1.550 Double Spring w/damper	1984-04 EVO/Twin Cam®**	230@1.875	700@1.200	1.100"	696
No.1349	1.510 Double Spring w/damper	1984-04 EVO/Twin Cam®**	184@1.85	422@1.280	1.080"	425
No.1300	1.095/1.445 Beehive Spring	2005 to pres. Twin Cam®** 2004 to pres. XL & Buell®	167@1.85	377@1.280	1.230"	370
No.1301	1.185/1.589 Beehive Spring	2005 to pres. Twin Cam®** 2004 to pres. XL & Buell®	193@1.85	373@1.240	1.150"	293

\*\* May also be used on High Performance Heads



## EVO & TWIN CAM® SPRING SEATS

JIMS® Spring Seats are custom machined to provide positive location in the Spring pocket to prevent the Spring from "dancing" around on the cylinder head which can create harmful harmonics and excessive wear. Made from Chromoly to JIMS® highest standards.

**SPRING SEATS ARE SOLD IN SETS OF 4 FOR ONE ENGINE**

PART NO.	DESCRIPTION	APPLICATION	THICKNESS	I.D.	O.D.
No.1377	Spring Seat (Set of 4)	EVO & Twin Cam® 1984-04**	.080"	.585"	1.500"
No.1309	Spring Seat (Set of 4)	2005 to present Twin Cam®** 2004 to present XL & Buell®	.060"	.585"	1.550"
No.1317	Spring Seat (Set of 4)	2005 to present Twin Cam®** 2004 to present XL & Buell®	.060"	.570"	1.590"

\*\* May also be used on High Performance Heads

**NOTE:** Engine builder still has the responsibility of checking and confirming the operating clearance when installing any of JIMS® products.



# RETAINERS & LOCKS



## VALVE SPRING-RETAINERS (TITANIUM)

JIMS® Titanium Upper Spring Collars fit all Evolution® Big Twins. They are stronger than stock retainers and 50% lighter. The reduced weight of our Titanium Retainer allows you to use less Spring pressure to do the same work. Less weight and Spring pressure allows the motor to rev quicker and create more horsepower.

**MADE WITH THE FINEST TITANIUM AVAILABLE  
AND MACHINED ON A C.N.C. LATHE.**

PART NO.	DESCRIPTION	APPLICATION	LOCK ANGLE	STEM SIZE	SPRING DIAMETER
No.1372	Titanium, double springs	1984-04 EVO & Twin Cam®	10°	All	1.437-1.500"
No.1373	Titanium, double springs	1984-04 EVO & Twin Cam®	10°	All	1.500-1.550"
No.1374	Chromoly, double springs	1984-04 EVO & Twin Cam®	10°	All	1.437-1.500"
No.1375	Chromoly, double springs	1984-04 EVO & Twin Cam®	10°	All	1.500-1.550"
No.1307	Titanium, Beehive Style	2005 to present Twin Cam® & 2004 to present XL & Buell®	10°	7mm	1.095-1.445"
No.1308	Titanium, Beehive Style	2005 to present Twin Cam® & 2004 to present XL & Buell®	10°	.310	1.185-1.589"
No.1302	Chromoly, Beehive Style	2005 to present Twin Cam® & 2004 to present XL & Buell®	7°	7mm	1.095-1.445"



## VALVE LOCKS

Quality valve locks are essential for any performance spring kit. JIMS® Super Valve Locks are made from the highest grade materials and are heat treated to JIMS® strict standards. Made for all models, Big Twin and Sportster®, 7mm, 3/8", and 5/16". JIMS® Super Valve Locks feature the time proven 7 or 10 degree lock angle and are made to fit our stronger than stock, super light weight titanium spring retainers, or any retainer with 7 or 10 degree lock angles. Available with or without lash cap recess clearance.

PART NO.	DESCRIPTION	YEAR	MODEL	ENGINE	LOCK ANGLE	STEM SIZE
No.1368	Super Locks w/lash cap recess	1948-84	Big Twin	Pan/Shovel	10°	3/8"
No.1369	+.050 inst. Hgt. w/o recess	1957-85	XL Exhaust	Sportster®	10°	3/8"
No.1370	Super Locks w/o lash cap recess Big Twins Sportster	1984-04 1986-03	Big Twin Big Twin XL Exhaust XL Intake 1957-85	Evo Big Twin Twin Cam 88® Evo Sportster® Ironhead Sportster®	10°	5/16"
No.1371	Super Locks w/lash cap recess Big Twins Sportster	1984-04 1986-03	Big Twin Big Twin XL Exhaust XL Intake 1957-85	Evo Big Twin Twin Cam 88® Evo Sportster® Ironhead Sportster®	10°	5/16"
No.1376	Super Locks w/lash cap recess	2005-present 2004-present	Big Twin Sportster® Buell®	Twin Cam® EVO EVO	7°	7mm

# PUSHROD COVERS & ACCESSORIES



## BILLET TWIN CAM OR EVO PUSHROD COVER SET

These "A Cut Above" billet pushrod covers are styled to give you a clean and smooth look. They feature a unique clip that looks like a complete tube while retaining the simple push-pull spring type function. Will work on any length cylinders utilizing spacer kits that are available below. **NOTE:** Will not fit JIMS stroker kit cylinders. For more details see No.3001-IS instructions.



Black

8

### TWIN CAM

- No.3000 - Bright dipped anodized.
- No.3003 - Black anodized.
- No.3004 - Chrome.
- No.3005 - Polished.

### EVOLUTION

- No.3002 - Chrome.
- No.3001 - Polished.



## PUSHROD COVER CLIP INSTALLING AND REMOVER TOOL

First thought... why would I need this tool, when I've been installing and removing OEM style pushrod covers for years with just a screw driver? Made from black delrin, this tool will NOT marr or slip – and will install the clip professionally with just one hand in seconds! It's a luxury tool you will appreciate for years to come. For more details see No.917-IS instructions.

No. 917 - Use on all V-Twins that use pushrod clips.



Use these for Taller Motors



## PUSHROD COVER SPACERS

JIMS® spacers are used to space up the pushrod covers above when taller than stock cylinders are used. Available in four sizes.

- No.1093SP4K - .275 Thick - Pack of 4.
- No.1093SP3K - .225 Thick - Pack of 4.
- No.1093SP2K - .200 Thick - Pack of 4.
- No.1093SP1K - .155 Thick - Pack of 4.



# PUSHRODS



## PRO-LITE WORKSAVERS ALL TWIN CAM®

JIMS® adjustable pushrods for Twin Cam® are strong, light, and made from aerospace quality heat treated aluminum with heat treated steel ends. No disassembly of top end, or removal of the Cam is required. These are the lightest pushrods on the market today, weighing in at about 70 grams. *For more details see No.2416-IS instructions.*

No.2416 - Use on all Twin Cam®. Pushrods have 24 threads per inch, with 3/8" balls on both ends.

**NOTE:** When using Twin Cam® Pushrod set No.2416 you will need to use (4) H-D® No.17938-83 lower pushrod covers and (4) H-D® No.17634-99 pushrod spring cover keepers.

8

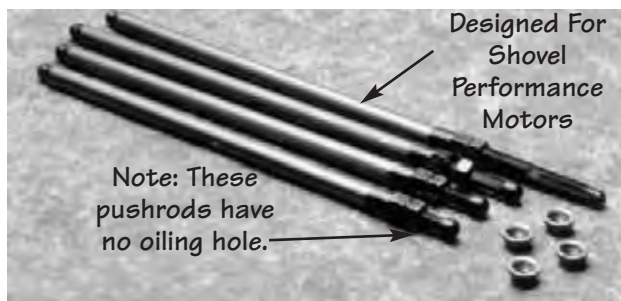

## "POWERGLIDE™" UPGRADE KIT

Now all of you Shovelhead owners, using JIMS® "Powerglide™" Tappets (.731" diameter only), can upgrade to the latest design improvements. Use on stock or performance applications. Kit comes with four new 3/8" diameter pushrod seats, to make the "Powerglide™" 5/8" shorter and four new Pro-Lite Worksavers Shovelhead Pushrods with no hole. Complete instruction sheet included.

No.2400 - Use on all Shovelheads and aftermarket engines using JIMS® "Powerglide™" Shovelhead Tappets No.2459-1, 2460-1, and 2461-1 with shovel top ends (.731" diameter only.) Pushrods have 24 threads per inch, and 3/8" ball on both ends.

**NOTE:** All of JIMS® pushrods eliminate the need to disassemble the top end or remove the rocker arms to change tappets, tappet blocks, pushrod cover seals, and cams.



## PRO-LITE WORKSAVERS EVO PUSHRODS

JIMS® Adjustable Pushrods, for Big Twins, are strong, light and made from aerospace quality heat treated aluminum, with heat treated steel ends. No disassembly of the top end, or removal of the cam is required. These are the lightest pushrods on the market today, weighing in at about 73 grams. These pushrods replace H-D® No.'s 17921-83, 17924-83, 17927-83, 17930-83 and S & S® No.93-5076. Will work with .200" taller cylinder.

No.2380 - Use on all Evo single cam only Big Twin 1984-99. Pushrods have 24 threads per inch, with 3/8" balls on both ends. **(NOTE:** Fits aftermarket engines.)

**NOTE:** Engine builder still has the responsibility of checking and confirming the operating clearance when installing any of JIMS® products.

Longer Adjusting Screws

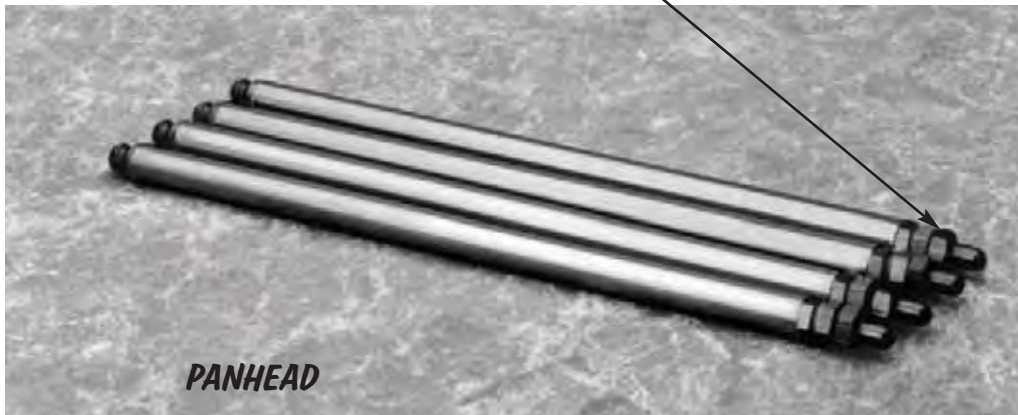

## **SLIM-JIMS® ALUMINUM PANHEAD PUSHRODS**

Made from aerospace quality aluminum tubing and heat treated steel ends. These lightweight pushrods provide maximum durability and long life. No disassembly of the top end or removal of the cam is required. JIMS® pushrods replace the stock steel rods and still retain the stock hydraulic unit. Combine these pushrods with JIMS® No.2459-1 "Powerglide™" Tappets for increased performance and reliability. Slim-JIMS® are extremely light and strong. These pushrods replace H-D® No.17905-53B and S & S® No.93-5050.

No.2404 - Use on Big Twin 1953-65. Pushrods have 32 threads per inch, with a 7/16" ball rocker end and a 1/4" ball tappet end. (**NOTE:** Also fits aftermarket engines.)

Longer Adjusting Screws



## **SLIM-JIMS® ALUMINUM SHOVELHEAD PUSHRODS**

Made from aerospace quality aluminum tubing and heat treated steel ends. These lightweight pushrods provide maximum durability and long life. No disassembly of the top end, or removal of the cam, is required. JIMS® pushrods replace the stock steel rods and still retain the stock hydraulic unit. Combine these pushrods with JIMS® No.2459-1 "Powerglide™" Tappets for increased performance and reliability. Slim-JIMS® are extremely light and strong. These pushrods replace H-D® No.17904-66 and S & S® No.93-5060.

No.2369 - Use on Big Twin 1966-84. Pushrods have 32 threads per inch, with a 3/8" ball rocker end and a 1/4" ball tappet end. (**NOTE:** Also fits aftermarket engines.)





## JIMS EVOLUTION CAM SHAFTS

JIMS Evo cam shafts were designed to work in a variety of engine combinations. All have a special lobe designed to maintain as wide a power band as possible with a ramp designed to cut down on noise. All of JIMS cams come with a new inner cam bearing No. 9058 bearing ( Torrington ).

**NOTE:** All cams fit 1984-1999 Evo's and all come with a 2.7364" size cam gear. It's Equivalent to a stock H-D red gear and is acceptable to use an existing stock gear for original fitment or use JIMS No. 24043-78 pinion gear for a matched set. Cams can be ordered with or without cam gear. See JIMS catalog for all cam tools.

**NO.1361G - BOLT IN HYDRAULIC (WITH INNER CAM BEARING)**  
**NO.1361 - WITHOUT CAM GEAR**

Bolt in Cam with a broad useable torque band that comes on early and pulls throughout the 2000-6000 R.P.M. range.

	Open/Close	Duration	Valve Lift	Lobe Center	Rocker Ratio	Lobe Separation Angle
Intake	16.0/38.0	234.0	net.308 / .500	101.0	1.625:1	104.5
Exhaust	50.0/14.0	244.0	net.308 / .500	108.0	1.625:1	

No.1361G & No.1361 - Use on 1984-1999 Evo Models.

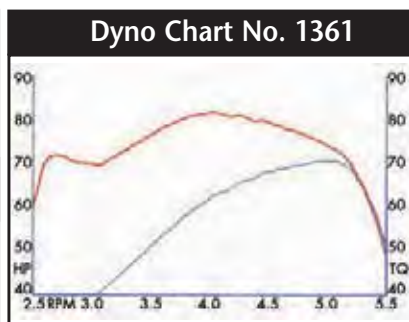

**NO.1362G - PERFORMANCE HYDRAULIC (WITH INNER CAM BEARING)**  
**NO.1362 - WITHOUT CAM GEAR**

89" to 113" C.I.D. engines, 9.75:1 compression for better and stronger valve springs are a must. Torque comes on strong at low R.P.M and stays almost linear throughout entire R.P.M. range. Excellent top end power at 3000 to 6000 + R.P.M.

	Open/Close	Duration	Valve Lift	Lobe Center	Rocker Ratio	Lobe Separation Angle
Intake	24.0/50.0	254.0	net.348 / .565	103.0	1.625:1	105.0
Exhaust	56.0/22.0	258.0	net.348 / .565	107.0	1.625:1	

No.1362G & No.1362 - Use on 1984-1999 Evo Models.

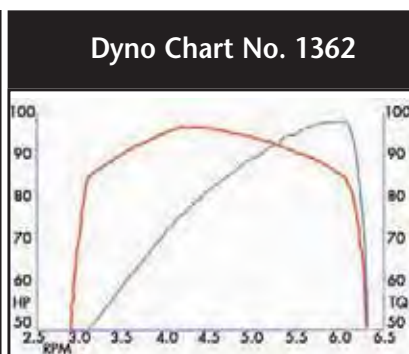

**NO.1363G - HIGH PERFORMANCE (WITH INNER CAM BEARING)**  
**NO.1363 - WITHOUT CAM GEAR**

93" to 120" C.I.D. engines, high compression and ported heads are a must. Same characteristics as the No.1362, but with more top end power potential at 2,800-6,000+.

	Open/Close	Duration	Valve Lift	Lobe Center	Rocker Ratio	Lobe Separation Angle
Intake	28.0/56.0	264.0	net.369 / .600	104.0	1.625:1	108.0
Exhaust	68.0/24.0	272.0	net.369 / .600	112.0	1.625:1	

No.1363G & No.1363 - Use on 1984-1999 Evo Models.

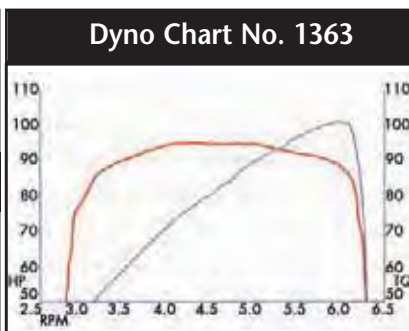

**NO.1364G - STREET / STRIP (WITH INNER CAM BEARING)**  
**NO.1364 - WITHOUT CAM GEAR**

Full race cam for EVO Big Twin

	Open/Close	Duration	Valve Lift	Lobe Center	Rocker Ratio	Lobe Separation Angle
Intake	31.0/59.0	270.0	net.406 / .660	104.0	1.625:1	109.0
Exhaust	72.0/24.0	276.0	net.406 / .660	114.0	1.625:1	

No.1364G & No.1364 - Use on 1984-1999 Evo Models.

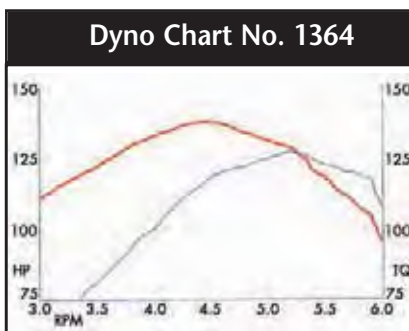

# POWERGLIDE™ TAPPET INFORMATION

## HYDRAULIC TAPPET ADJUSTMENT

Install tappets per H-D® Service Manual.

- If the pushrods you are using are adjustable, proceed as follows:
- With the Powerglide™ tappet installed, start with the front tappet at the lowest point on the cam and extend the pushrod to zero lash (no up and down play, but has a light spin).
- Extend the pushrod adjuster 15 wrench flats if pushrods have 24 threads per inch, 17 wrench flats if pushrods have 28 threads per inch, 18 wrench flats if pushrods have 32 threads per inch, 21 wrench flats if pushrods have 36 threads per inch, 24 wrench flats if pushrods have 40 threads per inch and 30 wrench flats if pushrod has 52 threads per inch. Tighten lock nut. **NOTE:** Popular pushrod adjustments below. Refer to individual lifter instruction sheet for adjustment information.

### PUSHROD ADJUSTMENTS-FOR REFERENCE ONLY!

**NOTE:** Use the instructions that came with your tappets

Threads per inch	Wrench flats	Total travel distance	Distance per turn	Distance per flats
24	15	.1042"	.0417"	.0069"
28	17	.1011"	.0357"	.0059"
32	18	.0937"	.0313"	.0052"
36	21	.0965"	.0275"	.0045"
40	24	.100"	.025"	.0042"
52	30	.0962"	.0192"	.0032"

### POPULAR PUSHRODS

#### MANUFACTURES THREADS PER INCH

JIMS® Pro-lite	24	No.s 2380, 2400
Slim JIMS	32	No.s 2404, 2369
Andrews	28	
Andrews	32	
Crane	28	New Time Savers
Crane	24	Old Time Savers
Crane	32	
H-D®	32	
S&S®	32	
Screamin Egl.	32	
Rivera	40	Taper Lite
Rev Tech	36	

**IMPORTANT NOTE:** This adjustment will make the pushrod tight, which will bleed the hydraulic lifter. It can take 5-15 minutes, or longer, to bleed off. It is very important that the engine is not rotated while pushrods are tight. The pushrod will spin with your fingers after the tappet has bled off.

- Recheck lock nut, close covers and install clips.
- Repeat exact procedure on rear set.
- Turn motor over several times until oil pumps into the Powerglide™ tappets, and the oil light goes out, or until oil is returning to the oil tank.
- These tappets will work best in JIMS® Tappet Blocks with a running clearance of .0007" to .0012".
- JIMS® Powerglide™ Tappets can also be run in H-D® blocks, with excellent performance results.
- JIMS® Powerglide™ Tappets are assembled with a small amount of oil to ease in the adjustment.

## FOUR POSSIBLE REASONS THAT MAY KEEP NEW HYDRAULIC UNITS FROM WORKING PROPERLY

**IMPROPER FIT • MECHANICAL • CONTAMINATION OF OIL SUPPLY • LOW OIL SUPPLY**

### 1. IMPROPER FIT

- a) Not likely, each unit goes through two separate dimensional tests. The fit is checked twice, to within .00015" to .0002".
- b) Second, a hydraulic bleed down test is performed dry, then with 5 weight oil.

### 2. MECHANICAL

- a) Not adjusted properly. Re-adjust per tappet instruction sheet. For tappet No's. 2456-1 and 2459-1, the hydraulic unit itself needs to be at .100" ± .010" below snap ring. For No.1029-53B tappet and block kit, the hydraulic unit itself needs to be .050" ± .010" below the snap ring. Some Shovel models from 1978-80 have tappet blocks with oil drain holes positioned too low. If running a



higher lift cam than stock, and sometimes even stock, these blocks will allow oil pressure to bleed off from the tappets. This is most common in the front tappet block.

- b) Any one of the following will cause a valve train to become noisy; a bent pushrod, loose valve guides, a broken valve spring, a valve hitting a piston, a valve hitting a valve, a loose rocker bushing, a rocker tip wearing at the valve stem, and a lifter roller hitting the tappet block will all cause a noisy valve train.
- c) Gear lash: If you did not change the cam at the time you installed new hydraulic units and had no gear lash, but a slight whine when motor was cold, it is safe to say you are OK in this area.
- d) Broken hydraulic valve spring which is not allowing valve to seal. If this is the case the hydraulic unit will not hold oil pressure. We have not seen this situation on any of JIMS® hydraulic units.

To check this, hold pushrod with your hand (with lifter on the heel of cam valve shut) and push down on pushrod. Hydraulic unit will feel spongy. Do not mistake this for no oil getting to tappet. If all tappets are spongy, this indicates there is no oil. If just one tappet is spongy that has been re-adjusted, but will not pump up, replace the tappet.

### 3. CONTAMINATION OF OIL

- a) With contamination of oil, the hydraulic unit may work for a minute and then become noisy. Most of the time it is more than one hydraulic unit that will be contaminated to the point of being stuck in the downward position.
- b) Re-adjust per instruction sheet. If hydraulic unit will not come back up to the top of snap ring, replace hydraulic unit and wash out the entire oil system.

### 4. OIL PRESSURE AT NORMAL OPERATING TEMPERATURE, AT ABOUT 2000 RPM, SHOULD BE 12-35 p.s.i..

- a) Check lifter filter screen (Big Twin).
- b) Make sure you are getting oil to the lifters. Install oil pressure gauge for top end oil.
- c) Lifter to tappet block clearance is best at .0007"-.0012".
- d) Lifters work best with 20-50w motorcycle oil.
- e) If lifters are quiet when cold or at a low RPM range and become noisy as RPM is increased, there is either not enough oil pressure, or too much clearance from lifter to block bore (Refer to "c").
- f) To isolate a possible noisy hydraulic lifter, start with a cool motor and the lifter you think is making the noise. With the lifter on the heel of cam, valve shut, adjust the pushrod so lifter unit is all the way compressed down. This is very important! This adjustment will make the pushrod tight which will bleed down the hydraulic lifter. It will sometimes take five minutes, or longer, to bleed down. Do not rotate engine while pushrods are tight. Go to the point where the pushrod will spin with your fingers. Adjust down a little more until pushrod becomes tight (so you can just barely turn with your fingers). Start bike. If it is quiet, then you have found the lifter that was not working properly. If it is still noisy, continue with the next lifter until you have located the the noisy one. Readjust per instruction sheet, or replace lifter.

### **THE FOLLOWING IS SOMETIMES MISTAKEN FOR NOISY TAPPETS:**

- A. *The most common being the clearance between cam gear and pinion gear (referred to as gear lash). If you did not change the cam at the time of installing this kit and had no gear lash but a slight whine when motor was cold, it is safe to say you are OK in this area.*
- B. *Rocker arm end play at .004" to .010" is good.*
- C. *Oil pressure at normal operating temperature about 2000 RPM should be 12-35 p.s.i. on Big Twin models, and 10-17 p.s.i. at 2500 RPM on Sportster® models.*
- D. *Check valve to guide clearance.*
- E. *Some Cams with fast ramps.*

# TWIN CAM®, POWERGLIDE TOOLS

## **NEW TWIN CAM® CASE SAVER FOR OVERSIZE TAPPETS**



This new tool can be a case saver if you have worn out or damaged tappet bores on any Twin Cam engine case. This reamer tool is designed to ream the case to fit a JIMS No.1811 +.010 oversize Twin Cam Powerglide™ II lifter. This tool includes a top quality reamer designed to perform a perfect finish hone on each tappet hole. *For more details see No.789-IS instructions.*

No.789- Use on any Twin Cam engine, OEM, or aftermarket.

9



**Bob Grimes**



**Charly Abraham**

## **NEW JIMS TAPPET PUMP AND TEST STAND**

Having issues getting your tappets to pump up or not sure if you have an oiling problem? Isolate the issue by using the new JIMS tappet pump and test stand. Fits standard size Twin Cam or Evolution lifters. For more information see part No. 765 and No. 766 on page 131.



Optional EVO Sleeve



# TWIN CAM<sup>®</sup>, POWERGLIDE II TAPPETS

## BIG AXLE "POWERGLIDE" II HYDRAULIC TAPPETS FOR ALL TWIN CAM<sup>®</sup> PERFORMANCE AND STOCK CAMS (SEE INSTRUCTION SHEET FOR COMPREHENSIVE TAPPET ADJUSTMENTS)



### POWERGLIDE™ II

JIMS<sup>®</sup> has been manufacturing tappets for over 30 years, and is the only aftermarket manufacturer that manufactures all our tappets in house.

This lifter has developed into the motorcycle's industries most popular performance tappet for Twin Cam. They have a proven track record to back them up. This tappet has undergone extensive development to increase its load, lubrication, hydraulic and life capacities. The Powerglide<sup>®</sup> II, has all the advantages of it's predecessor - billet body, superior hydraulic unit, roller perpendicularity held to .0002", hand-honed hydraulic unit cavity, and now includes the following advantages:

- The total dynamic load capacities have been increased over 30% straight across the board.
- The lubrication capacities for the hydraulic unit and valve train (top end) have increased 10%.
- The lubrication capacities for the roller, cams, and cam bearings have increased 100%. (Increased cooling) For more details see No.1807-IS instructions. This tappet replaces and surpasses H-D<sup>®</sup> No.18538-99B or JIMS<sup>®</sup> No.1806 Powerglide.

#### OIL FED AXLE

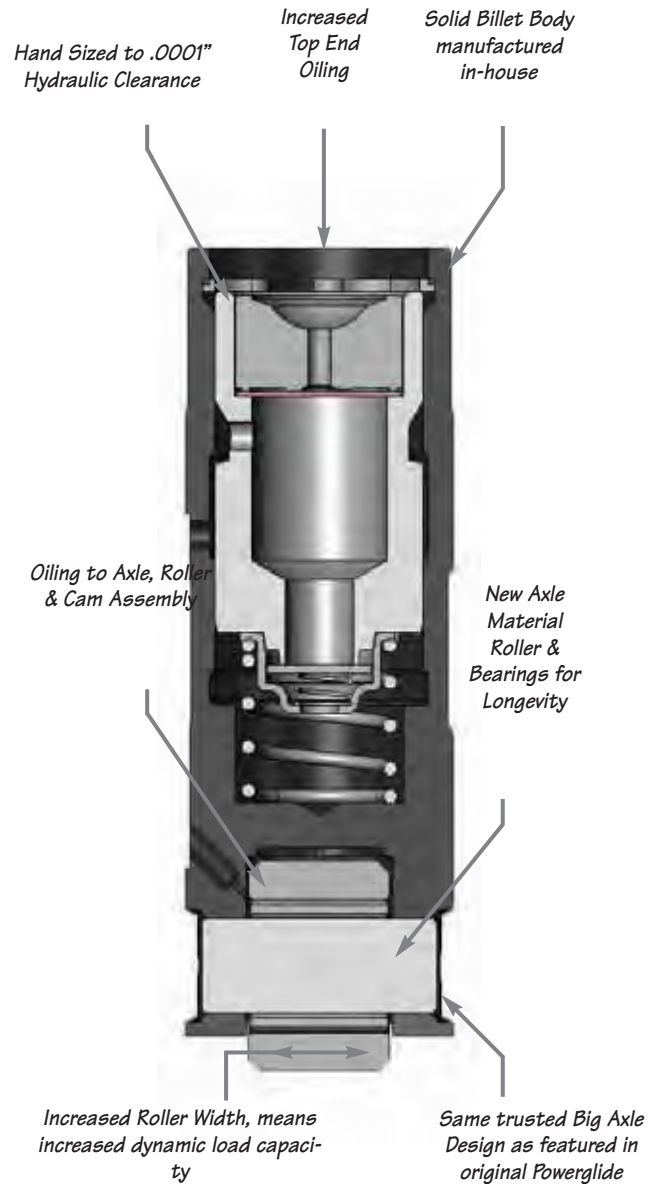

### TWIN CAM<sup>®</sup> POWERGLIDE™ II TAPPET

No.1807 - Use on all Twin Cams 1999-present, also Sporster<sup>®</sup> and Buell<sup>®</sup> 2000 to present. Standard O.D. is .8420".

No.1808 - Oversize +.001".

No.1809 - Oversize +.0015".

No.1810 - Oversize +.005".

No.1811 - Oversize +.010" (Note: For this tappet see JIMS Twin Cam case saver tappet reamer tool on the right.

**IMPORTANT NOTE:** Preliminary tappet adjustment will make the pushrod tight. You must wait 5-15 minutes or longer to fully bleed off the hydraulic tappet (Tappets come pre-oiled). It is very important that the engine is not rotated while pushrods are tight. The pushrod will spin with your fingers after the tappet has bled off. Never turn the engine over if the tappet will not spin with your fingers after adjustments were made.

† If counter adjusting is more than 3-5 wrench flats in either direction please call JIMS<sup>®</sup> for further advice.

# THE "HYDROSOLID"

## IS IT HYDRAULIC? OR IS IT SOLID?

This amazing tappet has broken the barriers of previous tappet designs. This tappet performs like a hydraulic tappet from start up to about 5500 RPM, and then turns into a solid from 5600 RPM to your set RPM rev limiter. At the same time it becomes a solid, it also adds about 3-6 more usable horsepower. What this all comes down to is that about the time your springs start to surge and go into harmonic distortion and the tappet rollers start lifting off the back side of the cam, you can be at ease knowing that your JIMS® Hydrosolid Tappet will not pump up, allowing your valves to hit. Must use with adjustable pushrods.

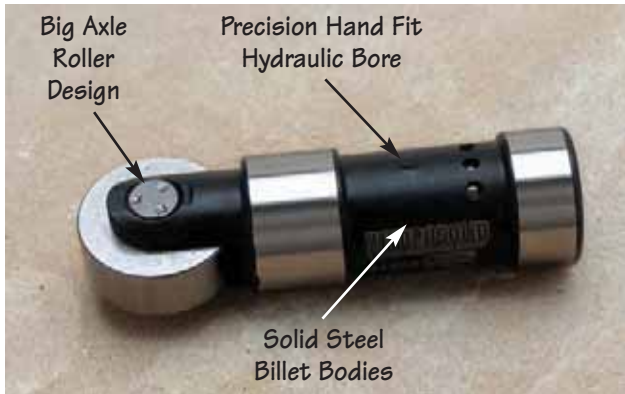

9

### BIG TWIN HYDROSOLID TAPPET

This tappet replaces and surpasses H-D® No.1852386 and S&S® No.33-5341.

For more details see No.1800-IS instructions.

Total Hydraulic Movement: 0.050"

No.1800 - Use on Big Twin 1984-99, Sportster® 1986-90 and Buell® 1987-90. Standard O.D. .8425".

No.1800-2 - Oversize +.002".

No.1800-5 - Oversize +.005".

**\*IMPORTANT NOTE:** Preliminary tappet adjustment will make the pushrod tight. You must wait 5-15 minutes or longer to fully bleed off the hydraulic tappet (Tappets come pre-oiled). It is very important that the engine is not rotated while pushrods are tight. The pushrod will spin with your fingers after the tappet has bled off. Never turn the engine over if the tappet will not spin with your fingers after adjustments were made.



### TWIN CAM® HYDROSOLID™ II TAPPETS

This tappet replaces and surpasses H-D® No.18538-99. Use with JIMS® No.1043 billet lifter covers.

For more details see No.1820-IS instructions.

Total Hydraulic Movement: 0.050"

No.1820 - Use on All Twin Cam®, standard O.D. is .8420".

Use on Sportster® 2000-present.

Use on Buell® 2000-present, except 1125R.

No.1821 - Oversize +.001".

No.1822 - Oversize +.0015".



### SPORTSTER® HYDROSOLID TAPPETS

This tappet replaces and surpasses H-D® No.18529-89. Std. O.D. is .9035".

For more details see No.1803-IS instructions.

Total Hydraulic Movement: 0.050"

No.1803 - Use on all 1991-99 XL & Buell.



# BIG TWIN EVO TAPPETS

## JIMS BIG AXLE "POWERGLIDE™"

### HYDRAULIC TAPPETS FOR EVO PERFORMANCE AND STOCK CAMS (WILL ALSO WORK WITH SOLID STYLE CAMS)

The title tells the whole story. Power is what you are after when you've installed a high performance hydraulic cam in your EVO motor.

To get full power, you must have zero valve lash, and eliminate collapsing of the hydraulic tappet as found in stock hydraulic units. This is referred to as the shock absorber syndrome. Failing to open the full amount as the cam is designed to do, results in power loss.

"Powerglide™" eliminates the shock absorber action. "Powerglide™" is as close to a solid tappet as possible and is still able to compensate for heat expansion.

Glide is what you get when hand matching hydraulic components to a running fit of .0002". For this reason "Powerglide™" tappets have a microfinished bore for the hydraulic unit to glide over. "Powerglide™" tappets are right at home in H-D® tappet blocks, unlike other performance tappets that require special tappet blocks. These tappets will run in cast iron or aluminum tappet blocks. JIMS® recommends fitting the tappets to the blocks with a clearance of .0007" to .0012". For worn out tappet blocks JIMS® is proud to offer +.002", +.005" and some .010" oversize tappets.

### MADE FROM BILLET BEARING STEEL EVO HYDRAULIC TAPPET

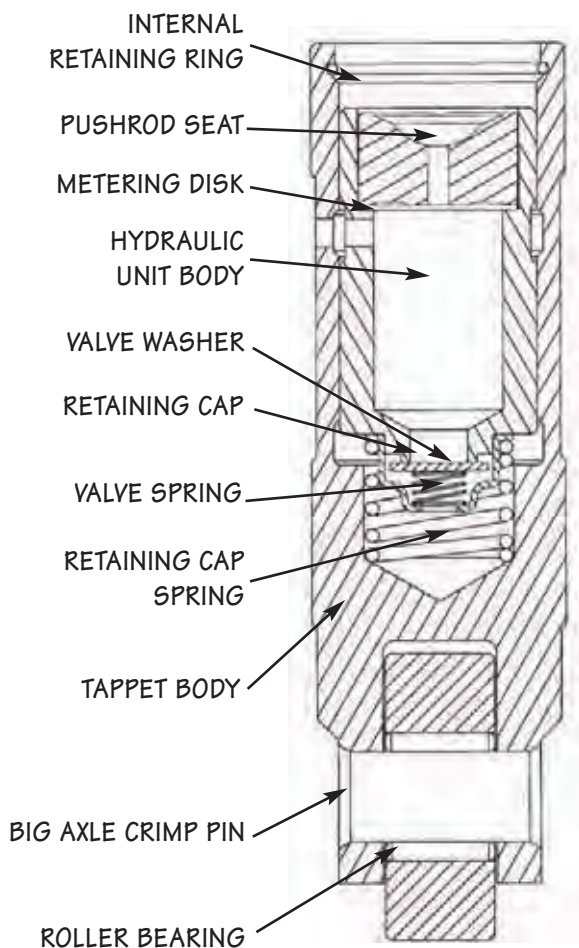

#### THE POWERGLIDE™ ADVANTAGE

1. Longest valve train engine life.
2. Produced from billet bearing steel. The same high quality steel our shafts and crank pins are made from.
3. The best made JIMS® big axle roller.
4. The ultimate in hydraulic control system, performs better under both the lower and the higher RPM limits, and high spring pressures.
5. A true centerline for roller life and exact cam timing.
6. State of the art pushrod seat, machined with the same segmented parabolic cup as the JIMS® roller rockers. Helps eliminate pushrod whip.
7. Engineered on a state of the art CAD System, and machined in some of the world's most accurate precision computer controlled machinery.
8. Hand fit hydraulic unit to a running fit of .0002", with ultra precision air gauging system.
9. All hydraulic units are tested 100% for function under a simulated pressure test fixture.
10. The best warranty policy in the industry.

"Powerglide™" tappets are capable of the highest RPM a Harley® can safely turn (about 8025 RPM) at a valve lift of .700", with the right valve springs, valves, cam, oil, etc. We recommend using with JIMS® tappet blocks No.1094. It is not necessary to use a limiting travel washer in "Powerglide™" tappets. For ALL OUT performance use a Hydrosolid tappet.

# BIG TWIN EVO XL TAPPETS

## BIG AXLE POWERGLIDE HYDRAULIC



### BIG AXLE POWERGLIDE™ BIG TWIN HYDRAULIC TAPPET

Standard O.D. is .8425". Individual tappet weighs 149 grams. This tappet replaces and surpasses H-D® No. 18523-86 and S&S® No.33-5341. For more details see No.2272-IS instructions.

No.2456-1 - Use on Big Twin Single Cam only 1984-99, aftermarket engines.

Use on Sportster® 1986-90.

Use on Buell® 1987-90.

No.2457-1 - Oversize +.002".

No.2458-1 - Oversize +.005".

## BIG AXLE SOLID EVO



### BIG AXLE SOLID TAPPET

Must use adjustable pushrod. Std O.D. is .8425". Individual tappet weighs 109 grams.

No.2465-1 - Use on Big Twin Single Cam only 1984-present, aftermarket engines.

Use on Sportster® 1986-90.

Use on Buell® 1987-90.

No.2466-1 - Oversize +.002".

No.2467-1 - Oversize +.005".

## EVO HYDROSOLID



### BIG TWIN HYDROSOLID TAPPET

This tappet replaces and surpasses H-D® No.18523-86 and S&S® No.33-5341. For more details see No.1800-IS instructions.

Total Hydraulic Movement: 0.050"

No.1800 - Use on Big Twin 1984-99, Sportster® 1986-90 and Buell® 1987-90. Standard O.D. .8425".

No.1800-2 - Oversize +.002".

No.1800-5 - Oversize +.005".



### JIMS TAPPET PUMP AND TEST STAND

Having issues getting your tappets to pump up or not sure if you have an oiling problem? Isolate the issue by using the new JIMS tappet pump and test stand. Fits standard size Twin Cam or Evolution lifters. For more information see part No. 765 and No. 766 on page 131.



## **STOP TAPPET NOISE FOREVER WITH "POWERGLIDE™" HYDRAULIC TAPPETS FOR PAN AND SHOVEL PERFORMANCE CAMS (WILL ALSO WORK WITH SOLID STYLE CAMS)**

Now you can have the same hydraulic function as EVO's. Are stock hydraulic units wearing you down? Are you installing solid tappets just so you will know what adjustment your tappets are set at? STOP! You need the "Powerglide™" solution. At about 30% cost savings and about 85% more stability, these tappets are perfect in Panhead and Shovelhead tappet blocks use with H-D® Part No.18600-53 (front) and No.18610-53 (rear). Will also work in any tappet block and case having oil passages to tappet blocks pre EVO. These tappets will accommodate a .550" lift or more without modification depending on the cam base circle size when using JIMS® tappet blocks No.1095. If using stock H-D® tappet blocks, check for roller to block clearances. Use with H-D® No.17904-66 or JIMS® No.2369 Pushrods for Shovelhead. For Panhead, use H-D® No.17905-53B or JIMS® No.2404 pushrods.

### **BILLET STEEL PERFORMANCE POWERGLIDE™ HYDRAULIC TAPPET FOR PANS AND SHOVELS**



#### **POWERGLIDE™ PAN AND SHOVEL HYDRAULIC TAPPET**

For more details see No.1800-IS instructions.

Std. O.D. is .731".

No.2459-1 - Use on Big Twin 1953-84, aftermarket engines. See Instructions No.2275-IS.

No.2460-1 - Oversize +.002".

No.2461-1 - Oversize +.005".

**NOTE:** Surpasses and replaces H-D® No.18522-53 tappet and H-D® No.17920-53A hydraulic unit. We recommend using with JIMS® tappet blocks No.1095. Standard outer diameter is .731" (Caution: some H-D® blocks 1978-84 have oil drain hole location problems with some high lift cams).



#### **"POWERGLIDE™" UPGRADE KIT**

Now all of you Shovel motor riders, using JIMS® "Powerglide™" Tappets No.2459-1, can upgrade to the latest design improvements. Use on stock or performance applications. Kit comes with four new 3/8" diameter pushrod seats to make the Powerglide™ 5/8" shorter, and four new Pro-Lite Worksavers® Shovel Pushrods (no hole) with complete instruction sheet. For use with above tappets 2459-1 when used with pushrod seats. For more details see No.2400-IS instructions.

No.2400 - Use on all Shovel Big Twins using JIMS® "Powerglide™" 2459-1, 2460-1, 2461-1. Shovelhead Tappets with shovel top ends. 24 threads per inch.



## HYDRAULIC TAPPET

Superseded by 18522-53. Standard. O.D. is .731".  
Weighs 89 grams

No.2462-1 - Use on Big Twin 1953-84, aftermarket engines.

No.2463-1 - Oversize +.002".

No.2464-1 - Oversize +.005".

**NOTE:** For use with No.2370 Hydraulic unit - (Pictured right).  
For solid tappets use No.2474-1 (See below).



## PAN & SHOVEL HYDRAULIC UNIT FOR STOCK HYDRAULICS

Crane® Pan and Shovel stock hydraulic unit. Use with Tappet No.18522-53. For pushrods on Shovelheads, use JIMS® No. 2369. For Panheads, use JIMS® No.2404 with a 5/16" rocker ball end, (**NOTE:** designed for stock hydraulic style cams and valve springs at stock RPM of about 5500 max). For the best hydraulics, use 2459-1. Hydraulic unit weighs 38 grams.

No.2370 - Use on Big Twin 1953-84, aftermarket engines.

9



## SOLID ADJUSTABLE TAPPET

Superseded by 18492-48. Standard. O.D. is .731".  
Weighs 86 grams. 9/32"-32 thread.

No.2474-1 - Use on Big Twin 1948-84, aftermarket engines. Use with JIMS® tappet blocks No.1095 or No.1095C.

No.2475-1 - Oversize +.002".

No.2476-1 - Oversize +.005".



## KNUCKLEHEAD SOLID ADJUSTABLE TAPPET

Use on 1936-47 H-D® Knucklehead and aftermarket engines. Standard O.D. is .731". 9/32"- 32 thread.

No.2607 - Use on 1936-47, Exhaust,

No.2608 - Use on 1936-47, Exhaust +.005".

No.2609 - Use on 1936-47, Intake.

No.2610 - Use on 1936-47, Intake +.005".

**NOTE:** For solid adjustable tappets - Adjusters and nuts sold separately, see page 59.



**“POWERGLIDE™” HYDRAULIC TAPPETS FOR SPORTSTER® AND BUELL® PERFORMANCE AND STOCK CAMS**



**BILLET STEEL POWERGLIDE II™ HYDRAULIC TAPPETS FOR SPORTSTER® AND BUELL®**

**NOTE:** This tappet replaces and surpasses H-D® No.18538-99B.

For more details see No.1807-IS instructions.

No.1807 - Use on Sportster® 2000-present. Use on Buell® 2000 to 2009. Use on Twin Cam®, standard O.D. is .8420”.

No.1808 - Oversize +.001”.

No.1809 - Oversize +.0015”.

No.1810 - Oversize +.005”.



“Powerglide™” tappets are capable of the highest RPM a Harley® can safely turn at a valve lift of .700” with the right valve springs, valves, cam, oil, etc. It is not necessary to use a limiting travel washer in “Powerglide™” tappets.



**BILLET STEEL POWERGLIDE™ HYDRAULIC TAPPETS FOR SPORTSTER® AND BUELL®**

Designed for high performance motors. Standard O.D. is .9035”. Clearanced for about .700” lift cams, however, you must still check lifter travel for performance cams. Individual tappet weighs 143 grams. For more details see No.2273-IS instructions.

No.18526-PG - Use on Sportster® & Buell® 1991-99.

No.18526-PG1 - Oversize +.001”.

No.18526-PG2 - Oversize +.002”.

No.18526-PG5 - Oversize +.005”.



**BIG AXLE POWERGLIDE™ HYDRAULIC TAPPETS FOR SPORTSTER® AND BUELL®**

Standard O.D. is .8425”. Individual tappet weighs 149 grams. This tappet replaces and surpasses H-D® No.19523-86 and S&S® No.33-5341. For more details see No.2272-IS instructions.

**NOTE:** Fits aftermarket engines.

No.2456-1 - Use on Sportster® 1986-90, Buell® 87-90.

No.2457-1 - Oversize +.002”.

No.2458-1 - Oversize +.005”.



**4340 CHROMOLY STEEL SCREW,  
WITH OIL HOLE, TO FEED TOP END.**

### SOLID ADJUSTABLE TAPPETS FOR SPORTSTER® AND BUELL®

Solid adjustable. Standard O.D. is .9035". Use non adjustable pushrods. (Clearanced for about .700" lift cams, however, you must still check lifter travel for performance cams.) Individual tappet weighs 146 grams.

No.18526-89SA - Use on Sportster® & Buell® 1991-99.

No.18526-89SA1 - Oversize +.001"

No.18526-89SA5 - Oversize +.005"

**WHILE  
SUPPLIES  
LAST**



### SOLID TAPPETS FOR SPORTSTER® AND BUELL®

Solid. Standard O.D. is .9035". Use adjustable pushrods (Clearanced for about .700" lift cams, however, you still must check lifter travel for performance cams). Individual tappet weighs 123 grams.

No.18526-89S - Use on Sportster® & Buell® 1991-99.



### SOLID TAPPET

Must use adjustable pushrod. Standard O.D. is .8425". Individual tappet weighs 109 grams.

**NOTE:** Fits aftermarket motors.

No.2465-1 - Use on Sportster® 1986-90, Buell® 87-90.

No.2466-1 - Oversize +.002".

No.2467-1 - Oversize +.005".



### SPORTSTER® HYDROSOLID™ II TAPPETS

This tappet replaces and surpasses H-D® No.18538-99. Use with JIMS® No.1043 billet lifter covers. For more details see No.1820-IS instructions. Standard O.D. is .8420".

Total Hydraulic Movement: 0.050"

No.1820 - Use on Sportster® 2000 to present.

Use on Buell® 2000-2009, except 1125R.

No.1821 - Oversize +.001".

No.1822 - Oversize +.0015".



**4340 CHROMOLY STEEL SCREW,  
WITH OIL HOLE, TO FEED TOP END**

### HYDROSOLID TAPPETS FOR SPORTSTER® AND BUELL®

Standard O.D. is .9035". This tappet replaces and surpasses H-D® No.18529-89.

For more details see No.1803-IS instructions.

No.1803 - Use on Sportster® & Buell® 1991-99.



### SOLID ADJUSTABLE TAPPET

Standard Solid Tappet. Standard O.D. is .731" 9/32"-32 thread. The 9/32"-32 thread adjuster screws and nuts must be purchase separately.

No.2471-1 - Use on Sportster® 1957-85.

No.2472-1 - Oversize +.002".

No.2473-1 - Oversize +.005".



# SIDE VALVE TAPPET & HARDWARE

**NOTE:** These rollers are intended for use on all small axle tappets. The Big Axle tappet rollers cannot be rebuilt.



## TAPPET ROLLERS

Made from 52100 bearing material, with 4340 chromoly axle.

No.18534-29A - Use on all models 1929-84.

No.18534-CP - 4340 chromoly axle only.

Caution: This axle must be crimped at 6000 psi minimum, with a radius crimping anvil.



No Thru Oil Hole

## TAPPET SCREW

Sold in a pack of 4. 3/8" ball end. 9/32"-32 thread.

No.18555-36K - Use on Big Twin tappet No.18492-48. Use on all JIMS® or any adjustable tappet having 9/32"-32 thread.



## TAPPET SCREW NUTS

Use on tappet screws. Sold in a pack of 4. 9/32"-32 thread.

No.18570-38K - Use on all JIMS® or any adjustable tappet having 9/32"-32 thread.



## TAPPET SCREW

Sold in a pack of 4. 5/16" ball end. 9/32"-32 thread.

No.18554-57K - Use on Sportster® tappet No. 18508-52B. Use on all JIMS® or any adjustable tappet having 9/32"-32 thread.



## SOLID ADJUSTABLE TAPPET

Use on 45", 74" and 80" Sidevalves 1930-73, and "K" Models 1952-56. Individual tappet weighs 74 grams. The 9/32"-32 thread adjuster screws and nuts must be purchase separately.

No.2426-1 - Standard. O.D. is .731".

No.2427-1 - Oversize +.005".



## TAPPET SCREW

Sold in a pack of 4. 9/32"-32 thread.

No.18556-40K - Use on "K" models 1952-53. Use on Sidevalves 1915-73. Use on all JIMS® or any adjustable tappet having 9/32"-32 thread.



## JIMS® BILLET TAPPET COVERS FOR TWIN CAM® "A" OR "B"

These are the ultimate in high tech tappet covers with extra smooth lines. These covers are CNC machined from billet 6061-T6 and utilize the best chroming procedures available to guarantee the precision tolerances that JIMS® is known for. Covers come with gaskets and chrome hardware. Replaces H-D® No.25369-01.



CNC milled from 6061T billet aluminum.

9

**CHROME** No.1043 - (Chrome set) Use on all Twin Cam® 1999-Present.

**NEW** No.6031 - Polished

**NEW** No.6030 - Black Anodized



## **NEW** JIMS HANDCRAFTED BILLET WELDED TAPPET COVERS

These new Twin Cam billet handcrafted tappet covers come with the latest look, RawCut & Welded. They come to you plated with a Bright Dipped or Black Anodized finish. These covers have a handcrafted look, combined with clean precision cut machining and add in some welded accents make these pieces the latest in style. See other Handcrafted items to match up with on page 68. Screws & gasket included.

**NEW** No.6032 - Use to replace any Twin Cam OEM.No 25369-01 tappet cover, Alpha or Beta. Bright dipped anodized.

No.6033 - Black anodized.



## PAN & SHOVEL BILLET 7075-T651 TAPPET BLOCKS



These blocks replace and surpass H-D® No.'s 18603-80A and 18610-76A. Made from 7075-T651 billet aerospace quality aluminum, these beautiful highly polished Pan and Shovel tappet blocks are the perfect way to upgrade your earlier Big Twin. With no compromises, these extra strong tappet blocks are machined to the centerline of the cam and hold  $\pm.002$ ". The bores are held perpendicular to the flange to  $\pm.0002$ ". Pushrod cover pockets are machined to accept early style corks or later quad seals. Pushrod cover angles have been optimized for a leak tight seal. Designed to accommodate .550" lift at the valves. Blocks can be cleared for a higher lift cam with simple modification; see "Index" for tappet block clearancing. For use on 1953-Early 1976, use 1/4"-24 screws (JIMS® No.2406). For use on Late 1976-84, use 1/4"-20 screws (JIMS® No.1205). We recommend using JIMS®

tappets No.'s 2459-1 & 2462-1. (H-D No.18522-53) or JIMS No.2474-1 (H-D No.18492-48). For more details see No.1095-IS instructions.

No.1095 - Polished, Use on Pan and Shovel - Big Twins 1953-84. Includes 1-front block, 1-rear block and gaskets. See "Screw Applications" on next page.

No.1095C - Chrome, Use on Pan and Shovel - Big Twins 1953-84. Includes 1-front block, 1-rear block and gaskets. See "Screw Applications" on page 63.

**CHROME**



# EVO TAPPET BLOCK KITS

Optimized Pushrod Tube Counter Bores To Eliminate All Possible Oil Leakage

Counter Bored Screw Holes To Eliminate Chrome Popping



Tappet Blocks Keep Tappets Perpendicular and Flat to Cam Lobe, for the Ultimate in Tappet Roller Life

Squareness of Tappet Block Bore to Cam Lobe Centerline

## EVO BILLET 7075-T651 TAPPET BLOCKS

These blocks replace and surpass numbers 18542-83A and 18540-83A. Billet EVO Tappet Blocks are designed to accommodate a gross valve lift of .655" at the valves. This is about .350" at the tappets, leaving a clearance of .035" roller to block freeplay. Will clear most small base circle cams having a lift of .600" or more. We recommend using with JIMS® Tappets No.2456-1. Any cam over .655" lift needs to be checked and should have .035" to .045" roller to block clearance. **NOTE:** If using a cam with a higher lift, a simple modification to tappet blocks is all that is needed. For more details see No.1094-IS instructions.

**Caution:** You still need to follow cam manufacturers guidelines. Use JIMS® EVO tappet block alignment tool No.33443-84.

No. 1094 - Billet Polished Tappet Block Kit - Use on Big Twin single cam only 1984-1999, includes gaskets.

No. 1094-K - Billet Polished Tappet Block Kit - Use on Big Twin single cam only 1984-1999, includes gaskets & chrome screws.

**CHROME** No. 1094-C - Billet Chrome Tappet Block Kit - Use on Big Twin single cam only 1984-1999, includes gaskets.

**CHROME** No. 1094-CK - Billet Chrome Tappet Block Kit - Use on Big Twin single cam only 1984-1999, includes gaskets and chrome screws.



### BIG BORE EVO TAPPET BLOCK KIT

Use this kit on all Big Bore cases that have the cam case area moved out 1/4"-3/8". Supplied with our performance hydrosolids. For more details see No.1800 & No.1094-IS instructions.

**CHROME** No. 1092K - Use on all aftermarket Big Bore crankcases, chromed, with gaskets and screws.



### BIG BORE EVO TAPPET BLOCKS

Same as our No.1094 Tappet Blocks, but with corrected pushrod cover angles for Big Bore Cases that have cam case areas that are moved out up to 1/4"-3/8". For more details see No.1094-IS instructions.

**CHROME** No. 1092C - Use on all aftermarket Big Bore crankcases, chromed, with gaskets.

## STOP TAPPET NOISE FOREVER!



### JIMS® CHROMING

Here at JIMS®, we insisted we would never chrome our products, for the simple reason it is too hard to guarantee the precision tolerances that JIMS® is known for. However, now we're chrome plating with the best chroming and masking processes available. JIMS® guarantees that there is no chrome in the crucial motor areas. Take a look for yourself.

#### KIT COMES WITH:

- FRONT & REAR TAPPET BLOCKS
- "POWERGLIDE™" TAPPETS
- JIMS TAPPET BLOCK GASKETS
- CHROME TAPPET BLOCK SCREWS



## EVO BILLET, POLISHED, & CHROME 7075-T651 TAPPET BLOCK KIT WITH THE BIG AXLE "POWERGLIDE™" TAPPETS

This kit replaces and supercedes black wrinkle tappet block numbers 18622-85A, 18623-85A, and Plain tappet blocks No.'s 18540-86A and 18542-83A. Designed to accommodate a gross valve lift of .655" at the valves, leaving a clearance of .035" roller to block free play (Please note: If using a cam with a higher lift, a simple modification is all that is needed). These blocks will clear most small base circle cams having a lift of .655" or more.

JIMS® EVO Tappet Block Kit was produced to improve the stock tappet and tappet block area. Made from billet 7075-T651 aluminum with a tensile strength 3 times stronger than cast aluminum tappet blocks. These tappet blocks are machined to the center line of the cam and hold  $\pm .002$ ". Also, the bores are held perpendicular to the mounting flange to  $\pm .0002$ ".

Add the precision quality of JIMS® Tappet and you can't buy a better tappet block kit for your bike (Gaskets and chrome screws included).

For the ultimate in valve train technology and stability, add JIMS® Roller Rocker Arms (20 grams lighter than stock) and JIMS® Billet Cam Cover. Use with any EVO Big Twin adjustable pushrods. Use JIMS® EVO tappet block alignment tool No.33443-84 to align tappet block. *For more details see No.2276 and 1094-IS instructions.*

No. 2418 - Polished blocks, with screws and gaskets use on Big Twin single cam only, 1984-99.



No. 2419 - Chrome blocks, with screws and gaskets use on Big Twin single cam only, 1984-99.



## DRAG RACING VERSION



### BILLET 7075-T651 SPORTSTER® RACING TAPPET GUIDE

This is a RACING version of our best Sportster® tappet guide. This performance part is for special applications ONLY! (Tappet guide has no oil grooves or pushrod tube cover bores) These blocks are designed to accommodate a lift of about .800" at valve, or about .500" lift at cam. *For more details see No.2367-IS instructions. Sold in a set of 4.*

No.18607-57AR - Racing Version. Special application, no oil grooves or pushrod tube cover bores.



### SPORTSTER® BILLET POLISHED OR CHROME 7075-T651 TAPPET GUIDE

Made from the strongest aluminum alloy available, 7075-T651, and precision machined from billet stock with Helical style oil grooves for better lubrication. Use with JIMS® tappets No.2471-1. *For more details see No.18607-IS instructions.*

No.18607-57A - Polished, Use on Sportster® 1957-85.

No.18607-57AC - Chrome, Use on Sportster® 1957-85.

REMOVE OLD TAPPET WITH JIMS® TOOL NO.95724-57, TAPPET GUIDE PULLER.

CHROME

9

CHROME



### 12 PT. CHROME SCREWS

Use on Big Twin tappet blocks. Designed for EVO, late Shovels. **Sold in a set of 8.**

1/4"-20. All screws are 7/8" long.

No.1205 - Use on Big Twin single cam only Late 1976-99 (1/4"-20 thread). These screws replace and surpass H-D® No.3770.

No.2406 - Use on Big Twin 1953-Early 1976 (1/4"-24 thread). For use on late style tappet blocks that have no counter bore for screw.



### BLACK GASKET FOR TAPPET BLOCK

These are the highest quality gaskets available for use on Harley-Davidsons®. Our tests have shown these gaskets to be the best for alignment, and the best to take the torque evenly for excellent tappet block alignment. **Sold in a pack of 10.**

No.2358K - Front gasket. Use on Big Twin single cam only 1948-99. Pack of 10. These gaskets replace and surpass H-D® No.18634-48B.

No.2359K - Rear gasket. Use on Big Twin single cam only 1948-99. Pack of 10. These gaskets replace and surpass H-D® No.18633-48C.



**KIT COMES WITH:**

- **FRONT & REAR TAPPET BLOCKS**
- **"POWERGLIDE™" TAPPETS**
- **JIMS TAPPET BLOCK GASKETS**

## **PAN AND SHOVEL "POWERGLIDE™" BILLET 7075-T651 TAPPET BLOCK KIT**

- .761" diameter tappets not interchangeable with stock diameter (.731") tappets or blocks.
- Pan and Shovel "Powerglide™" Tappet Block Kits are capable of the highest RPM a Harley® can safely turn, at a valve lift of .700" with the right valve springs, valves, cam, oil, etc.
- Pan and Shovel motors can have all the hydraulic benefits of the late EVO style hydraulic system by installing JIMS® Shovel "Powerglide™" Hydraulic Tappets.
- These kits will eliminate the total oil loss of the stock hydraulic units, No.17920-53A.
- Billet Pan and Shovel Tappet Blocks with "Powerglide™" Hydraulic Tappets. Total Hydraulic Lift: 0.100".
- Comes complete with instructions.
- Tappet block gaskets included.

These tappet blocks replace and surpass lifter block No.'s. 18603-80A, 18610-76A and tappet No.'s. 18522-53A. Fits Pan and Shovel Big Twins 1953 through 1984. Use 1/4"-20 screws, JIMS® No.1205, from late 1976 through 1984. Use 1/4"-24 screws, JIMS® No.2406, from 1953 through early 1976. These blocks are designed to accommodate a gross valve lift of .550" at the valves, leaving a clearance of .035" roller to block freeplay (Please note, if using a cam with a higher lift, a simple modification is all that is needed). See page 61 for tappet block clearancing. Use with JIMS® pushrod No.2369 for Shovelheads, or No.2404 for Panheads, or equivalent. Blocks can be cleared for higher cam lift.

All JIMS® Billet Polished Tappet Blocks are made from 7075-T651 aluminum with a tensile strength of 83,000 psi, which is double the amount of 6061-T6 aluminum and almost triple the amount of cast aluminum tappet blocks. These tappet blocks are machined to the center line of the cam and hold to  $\pm.002"$ . Also, the bores are held perpendicular to the mounting flange to  $\pm.0002"$ . (Use quad seals for the best oil sealants possible.) *For more details see No.2274-IS instructions.*

No. **1029-53B** - Polished, with gaskets fits Pan 1953-65 & Shovel Big Twins 1966-84.

**CHROME** No. **1029-53C** - Chrome, with gaskets fits Pan 1953-65 & Shovel Big Twins 1966-84.

### **REPLACEMENT TAPPETS**

No. **1029ACAB** - Standard replacement tappet

No. **1029ACAB2** - .002" Oversize replacement tappet

No. **1029ACAB5** - .005" Oversize replacement tappet

**SEE JIMSUSA.COM FOR DETAILED INSTRUCTIONS**



# SHOVEL TAPPET BLOCKS



## **SUPER "POWERGLIDE™" TAPPET BLOCK KIT**

JIMS® has designed and engineered a complete block kit for shovel motors, whether stock or performance application. This kit has an upgraded pushrod seat at a 3/8" diameter and a 5/8" lower seat. Lowering the pushrod seat will help reduce the severe tappet pushrod angle, making JIMS® kit as close to an EVO tappet as possible. Kit comes with four Tappets with new pushrod seats, 7075-T651 tappet blocks polished, four Pro-Lite Worksavers® Shovel (No hole) pushrods, and two tappet block gaskets. These have a .761" diameter tappet with a total Hydraulic Lift of 0.100". For more details see No.2411-IS instructions.

**CHROME**

No.2411 - Polished, use on all Big Twins 1966-1984 (all Shovelheads).

No.2411C - Chromed, use on all Big Twins 1966-1984 (all Shovelheads).

**Replacement tappets for above kits; No.2411 and No.2411C, sold each:**

No.1029AP - Standard

No.1029AP2 - +.002 Oversized.

No.1029AP5 - +.005 Oversized.



## **PERFORMANCE "POWERGLIDE™" KIT (SHOVELHEAD)**

JIMS® lowered the rod seat and increased the pushrod seat diameter to 3/8" making this tappet as close to an Evo as possible. Kit comes with 4 JIMS® Powerglide™ Tappets, standard O.D. of .731, and a set of Pro-Lite Worksavers® Shovel (No hole) Pushrods. These tappets will fit in JIMS® Shovelhead Tappet Blocks, No. 1095, or stock tappet blocks. See No.2428-IS instruction sheet. Total Hydraulic Lift: 0.100". For more details see No.2428-IS instructions.

No.2428 - Use on Big Twin Shovelhead 1966-1984.

No.2428-5 - Use on .005 oversize on Big Twin Shovelhead 1966-1984.

# SHOVEL TAPPET BLOCK KITS



## KIT COMES WITH:

- **FRONT & REAR TAPPET BLOCKS**
- **"POWERGLIDE™" TAPPETS**
- **JIMS TAPPET BLOCK GASKETS**
- **JIMS PUSHROD SET WITH OIL HOLE**
- **JIMS ROLLER ROCKER ARM SET**

## REPLACEMENT TAPPETS FOR THE BELOW KITS;

**No.1046 & No.1046P, sold each:**

No.1029AP - Standard replacement

No.1029AP2 - .002" Oversize replacement

No.1029AP5 - .005" Oversize replacement

## MAKE YOUR SHOVEL COME ALIVE WITH JIMS® POWERGLIDE TAPPETS

With this kit installed in either a big 106 inch shovel or in a stock 74 inch daily rider – you will now have all the same high performance hydraulic tappet function as JIMS® high performance hydraulic tappet for EVO or Twin Cams.

Run the biggest cam you can find for a shovel to help squeeze out all the horsepower you have put in your shovel; with the right valves, valve springs, pistons and oil. No longer will the oil you have been trying to get to your rockers, through outside oil lines, be lost at the clearance around the rocker shaft to the rocker cover. With all four rocker shafts (new or used) having this clearance the amount of oil going to the rockers will be greatly reduced.

With these components; POWERGLIDE tappets, roller rocker arms, billet tappet blocks, adjustable pushrods, gaskets and plugs, you will have a valve train system that works without any maintenance. No longer will valve adjustments be needed every 2,000 miles as before with other hydraulic or solid tappets.

**POWERGLIDE TAPPETS:** These use the same hydraulic unit as JIMS® EVO and Twin-Cam tappets, they can be run against valve springs having over 800 lbs. of spring pressure (valve open) with cams having as much as .700" valve lift, axle roller installed within .0002" of parallelism to the body. The body is ground to better than a 16 finish and straight and round with in .0002". Also uses a low pushrod cup, having an optimized metering oil channel.

**ROLLER ROCKER ARMS:** The a ratio of 1.5:1 gives the valves far less roller tip push then any other shovel rocker being manufactured. Combining the above with 660 bronze bushings, line honed to .0007" fits to the rocker shaft. Roller tip and it's axle made from tool steel with pressurized oil hole, that will help lubricate not only the roller tip but also removes 35% more heat from the valve springs. Also a pushrod seat design (segmented parabolic) that will increase pushrod life by 35%, which now is lubricated with pressurized oil from the pushrods 3/8" ball end.

**TAPPET BLOCKS:** Blocks have been machined to the precision tolerances JIMS® is notorious for. All bores have been machined straight to the centerline of the cam thus increasing tappet and cam life. We've also designed the most advanced oil drains to help remove all the oil being returned from the heads to the return side of the oil pump. Included with all this precision machining we've added the best chroming process in the industry.

**PUSHRODS:** Adjustable pushrods with 24 threads per inch for ease of adjustment including stainless steel locking nuts to help hold adjusting screw tight. Light and straight with an oil hole threw both the pushrod ball ends similar to EVO and Twin Cams. With the above JIMS® powerglide tappets, JIMS® roller rockers and these pushrods, you will be able to remove your top end oil lines and plug them off with supplied plugs.

Now with all this installed to your valve train, your new top end oiling system will be updated to JIMS® top end oiling system, being the same as EVO and Twin Cams.

How it all works, oil that is pumped through the powerglide tappets, through each pushrod, thru each rocker.

For more details see No.1046-IS instructions.

**CHROME** No.1046 - (Chrome) Use on single cam only Big Twin 1966-84. (**NOTE:** Includes aftermarket engines.)  
(Use quad seals for the best possible oil sealant.)

No.1046P - (Polished) Use on single cam only Big Twin 1966-84. (**NOTE:** Includes aftermarket engines.)  
(Use quad seals for the best possible oil sealant.)



# SADDLEBAG LATCH COVERS, & FRONT HEAD MOTOR MOUNT



## BILLET SADDLEBAG LATCH COVERS



This new "A Cut Above" product will give you a touch of class with a custom look. The new billet saddlebag latch covers will easily bolt on original OEM latch mechanism. You have the option of ordering these covers plain or with custom engraved text up to a 15 space limit. See JIMS Sales Dept for details. *For more details see No.6037-IS instructions.*

Use on 1993 to present touring models:

No.6037 - Chrome

No.6036 - Polished

No.6035 - Black anodized



## BILLET FRONT HEAD MOTOR MOUNT



This new "A Cut Above™" billet engine mount has a more pleasing appearance and is stronger than an O.E.M. mount. The material is premium grade 6061T6 aluminum with optional chrome, polished, or black anodized finish. This mount comes with two chrome washers and allen screws for mounting to the head. An optional chrome heim joint link hardware kit is available with chrome screws and washer. Order link kit separately, No.1444, as shown below.

Front mounts are available for 2008 and later H-D® Touring Models or the same models using a JIMS® 120", 131", or 135" engine. Simple to install. Instructions included.

*For more details see No.1437-IS instructions.*

Billet engine head mount with chrome stabilizer link with hardware for 2008 to present touring models:

No.1437 - For chrome

No.1438 - For polished

No.1439 - For black anodized

Billet engine head mount with hardware for 2008 to present touring models.

JIMS 120", 131", or 135" engines.

No.1440 - For chrome

No.1441 - For polished

No.1442 - For black anodized

## CHROME HEIM JOINT LINK



This link kit includes a chrome plated heim joint assembly with chrome mounting hardware.

*For more details see No. 1437-IS instructions.*

No.1444 - Use on any JIMS Billet front Head Motor Mount, No.1437 through No. 1442, or 2008 to present touring models.

# WELDED CAM COVER, TAPPET BLOCKS, & TRANS SIDE COVER



## JIMS HANDCRAFTED COVERS

Picture this...Just over a year ago, Jim walking through a custom car show, downtown Ventura, CA. A handcrafted oil pan with skilled welds catches his eye. One year later, JIMS® has integrated a precision machined set of covers to outfit your late model HD with this latest new look - RawCut & Welded. Plating is a Bright Dipped Anodized. These are the same precision machined billet covers you would expect from JIMS - just hand welded. When combined with JIMS tappet covers, and a JIMS pushrod tube cover set these new JIMS covers will update your bike to a tough new handcrafted look. Screws & gasket included.

No. 2300 - Use on 2001 to present Twin Cam models. Bright Dipped Anodized.

No. 2301 - Black Anodized.



Black



## BILLET TWIN CAM OR EVO PUSHROD COVER SET

These "A Cut Above" billet pushrod covers are styled to give you a clean and smooth look. They feature a unique clip that looks like a complete tube while retaining the simple push-pull spring type function. Will work on any length cylinders utilizing spacer kits that are available below. **NOTE:** Will not fit JIMS stroker kit cylinders. For more details see No.3001-IS instructions.

### TWIN CAM

No.3000 - Bright Dipped Anodized.

No.3003 - Black Anodized.

No.3004 - Chrome.

No.3005 - Polished.

### EVOLUTION

No.3002 - Chrome.

No.3001 - Polished.



Black



11



## JIMS HANDCRAFTED BILLET WELDED TAPPET COVERS

These new Twin Cam billet handcrafted tappet covers come with the latest look, RawCut & Welded. They come to you plated with a Bright Dipped or Black Anodized finish. These covers have a handcrafted look, combined with clean precision cut machining, and add in some welded accents to make these pieces the latest in style. Screws & gasket included. Use to replace any TC OEM.No 25369-01 tappet cover.

No. 6032 - Alpha or Beta Bright Dipped Anodized.

No. 6033 - Black Anodized.



Black



## JIMS HANDCRAFTED TRANSMISSION SIDE COVER

These new billet transmission side covers come with the latest look, RawCut & Welded. They come to you plated with a Bright Dipped or Black Anodized finish. The cover has a handcrafted look, combined with a clean precision cut fin pack, and add in some welded accents making these pieces the latest in style. Order a JIMS Cam cover No. 2300 to match up with and you'll be No. 1. Screws & gasket included.

No. 2395 - Use on all 2006 to present H-D Cruise Drive 6-speed transmissions. Bright Dipped Anodized.

No. 2396 - Black Anodized.

No. 2394 - Use on all 1987 to 2006 Big Twin 5-Speed transmissions and aftermarket 6-speeds with a minor hardware change. (Not for FXR with controls.) Bright Dipped Anodized.

No. 2398 - Black Anodized.



Black





# BIKE POCKET & HEAT SINK CAM COVER



## JIMS BIKE POCKET

This new creative "A Cut Above" product will give your cam cover a new distinctive smooth look along with a "Bike Pocket" to hide your keys, registration, insurance paper work or your little black book. This cover easily attaches to any 2001 and later H-D Big Twin Cam cover. Just twist the outer cover for easy access. Now you can hide stuff on your motorcycle. For more details see No. 6038-IS instructions. **NOTE:** For use on any 2001 to present Big Twin Cam cover with a original style OEM, nose and timing cover.



Smooth Style

Bolt Circle Style

### SMOOTH STYLE

No. 6038 - Chrome

No. 6039 - Polished

No. 6040 - Black anodized

### BOLT CIRCLE PATTERN

No. 6050 - Chrome

No. 6051 - Polished

No. 6052 - Black anodized

**WARNING:** Do not place any items inside the Bike Pocket that can be effected by extreme heat to avoid damage, fire, or explosion. Do not try to handle the outer cover until the motorcycle has cooled off for at least an hour. Always wear heat proof gloves if not sure before handling.



## JIMS CAM COVER HEAT SINK



Chrome



Black & Rawcut



Not all engines maintain the same operating temperature. Big displacement, combustion chambers, cams, exhaust, spark, fuel, etc... can all increase operating temperatures. Introducing the patent pending JIMS Cam Cover Heat Sink. One of our calibration associates, Cornerstone Metrology ([www.cornerstonemetrology.com](http://www.cornerstonemetrology.com)) set out to prove that a fin pack design integrated into a stock cam cover could help reduce cam cover heat. When riding, this design uses outside air to help reduce cam cover temperatures up to 10 degrees. After adding a little JIMS DNA, you have a patent pending, American made cam cover insert not only looks cool, but helps reduce cam chest temperatures. These Heat Sink inserts are

completely machined out of solid 6061 aluminum, and are offered either in Chrome Plate, or RawCut black. Installation uses existing timing cover hardware and only takes minutes. For more details see No. 2311-IS instructions

No. 2303 - Black & RawCut – Use on 2001 to present Twin Cam models.

No. 2311 - Chrome - Use on 2001 to present Twin Cam models.

# EVO CAM COVERS

## "A CUT ABOVE™" POLISHED OR CHROME BILLET CAM COVERS

2-Piece Design

Includes Gaskets & Points Cover



The Perfect Centerline

Machined To Maintain Factory Centerlines For Perfect Cam/Pinion Alignment

Solid Bronze Bushings

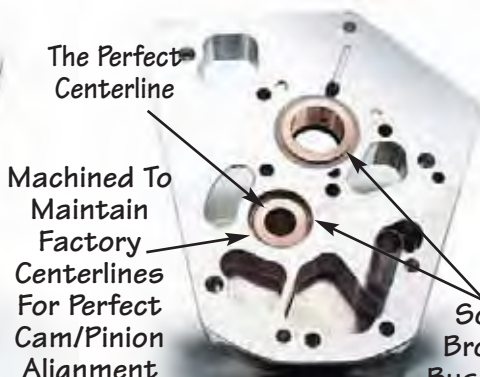

### BACKSIDE OF JIMS® CAM COVER 73-92 STYLE COVER

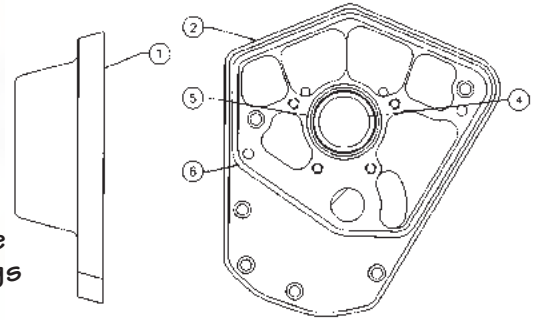

### POINTS COVER AND CAM COVER BASE GASKET INCLUDED

Made from 7075-T651 aluminum with a tensile strength of 83,000 PSI, which is double the amount of 6061-T6 aluminum and almost triple the amount of cast cam covers. This cam cover is positioned precisely to the centerline of the cam bushing and pinion bushing. In fact, this cam cover is within .0002" of where the factory intended it to be.

Why hold centerline that close, or why even care about centerline in a cam cover? We at JIMS® are concerned with the life of your motor. For this reason, we are helping you to achieve longer life for your valve train components, consisting of your cam, tappets and your tappet blocks.

Your camshaft must lie on the best possible foundation. The foundation we are concerned with is the centerline of the camshaft. If the camshaft is tilted off in any direction much more than the running clearance at each end of the camshaft, this will affect the way the tappet rollers ride on the cam lobe. If they are not riding flat, but on one edge of the roller, it could possibly shorten the life of your valve train. The camshaft is supported at both ends, while the inner cam bearing is a given. This means, the bearing is not going to move unless you do a lot of machining. Your cam cover must be right to the case centerline for the longest possible tappet and cam life. For early 73 to 92 cam covers see 25258-IS instructions or for late 93-99 use 25254-IS for more details.

### PARTS AVAILABLE SEPARATELY

NO.	QTY.	DESCRIPTION	PART NO.
1	1	CAM COVER OUTER - REP. 25258-80AC	2412
1	1	CAM COVER OUTER - CHROME	2521
2	1	BASE PLATE - EARLY	2522
2	1	BASE PLATE - EARLY CHROME	2524
2	1	BASE PLATE - LATE	2518
2	1	BASE PLATE - LATE CHROME	2525
4	1	SEAL CAM - USE ON 1970-PRESENT REP. H-D® NO.83162-51 (SINGLE CAM)	2169
5	1	O-RING SMALL	2170
6	1	O-RING LARGE	2171
7	2	SOCKET HEAD CAP SCREW LONG 1-1/2"	2027
8	8	SOCKET HEAD CAP SCREW SHORT 1-1/8"	2028

### CAM COVERS

No.25258-80A - Polished - Use on Big Twin single cam only 1973-92. **(NOTE: Includes aftermarket engines.)**

**CHROME**

No.2413 - Chrome - Use on Big Twin single cam only 1973-92. **(NOTE: Includes aftermarket engines.)**

No.25254-93A - Polished - Use on Big Twin single cam only 1993-99. **(NOTE: Includes aftermarket engines.)**

**CHROME**

No.2414 - Chrome - Use on Big Twin single cam only 1993-99. **(NOTE: Includes aftermarket engines.)**

### JIMS® BILLET & CHROMED BILLET POINTS COVER

Replaces H-D® No.32524-83. Use on Big Twin single cam 1970-present, Sportster® 1971-present and Buell® 1987-present. .190" thick polished 6061-T6 aluminum points cover. Covers come with JIMS® logo lasered on the face or plain. Two chrome flat head allen screws and gasket included.

No.2239 - Plain polished. Use on Big Twin (Single Cam) and Sportster®.

**CHROME**

No.2239C - Plain chrome. Use on all Big Twin (Single Cam) and Sportster®.

No.2239L - Polished, JIMS® logo. Use on Big Twin (Single Cam).

**CHROME**

No.2239LC - Chrome, JIMS® logo. Use on Big Twin (Single Cam).







## INNER CAM BEARINGS EARLY TWIN CAM®

These American made bearings are a must for any cam change or service. To remove bearings from case use JIMS® No.1279 Cam Bearing Remover Tool. To install bearings use JIMS® Tool No.1278. Doing service in this area will require other JIMS® tools as listed: No.1277 - Cam Shaft Remover and Installer; No.1285 - Cam / Crank Sprocket Lock; No.1283 - Cam Chain Tensioner Tool, and No.1280 - Outer Cam Bearing Puller (optional). **Sold in a pack of 2.**

No.9198K - Use on 1999 - 2006 FLH. Use on 2000 - 2006 FXST. Use on 1999 - 2005 FXD.



## INNER CAM BEARINGS LATE TWIN CAM®

These American made bearings are a must for any cam change or service. To remove bearings from case use JIMS® No.993 Cam Bearing Remover Tool. To install bearings use JIMS® Tool No.991. Doing service in this area will require other JIMS® Tools as listed: 2 - No.33443-84 - Pump Alignment Screws; No.1285- Cam/Crank Sprocket Lock; No.994 and No.990- Cam Assembly Tools. **Sold in a pack of 2.**

No.8991K - Use on 2006 - Present FXD. Use on 2007 - Present FXST and FL.



## MID TWIN CAM OUTER CAM BEARING KIT

These are quality bearings that meet or exceed factory OEM specifications H-D® No.8983 and 8990A. Use JIMS® tool No.1280 to pull bearing from front cam. To pull rear-bearing use JIMS® No.963 your bearing race puller wedge attachment. To install and remove camshafts use JIMS® No. 1277.

No.8150 - Use on mid 2000 - 2006 FLH & FXST.  
Use on mid 2000 - 2005 FXD.



## EARLY TWIN CAM® OUTER CAM BEARINGS

These are quality bearings that meet or exceed factory OEM specifications. Replaces H-D® No.8890. **Sold in pairs.**

No.8990K - Use on Twin Cam 88® 1999 - mid 2000.



## INNER CAM BEARING SPORTSTER®

American made by Torrington®. For the best results install bearing with JIMS® Cam Bearing Installation JIMS® Tool No.97273-60. To remove bearing use JIMS® Tool 95760-XL.

No.9057 - Use on Sportster® 1957-1990, Use on Buell® 1987-1990.

(NOTE: Includes aftermarket engines.)



## INNER CAM BEARING BIG TWIN

This is the original and only cam bearing to use in your Big Twin. American made by Torrington®. Don't trust any other Cam Bearing. For the best results, install bearing with JIMS® Cam Bearing Installation Tool No.2188. To remove Cam Bearing use JIMS® No.95760-TB Cam Bearing Puller. To remove cam cover use JIMS® Tool No.2243.

No.9058 - Use on Big Twin 1958-99 single cam only.

(NOTE: Includes aftermarket engines.)



## CNC MACHINED BUSHINGS

All of JIMS® bushings are made from solid bronze bar stock, Mil Spec 11553C12. Each bushing is machined in one operation that holds the concentricity to less than .0002". Also, each bushing has a lead in, for ease of installment.



### CAM BUSHING, IN CAM COVER

Big Twin Standard O.D. is 1.2015". Standard I.D. is 1.000". Use JIMS® line reamer No.1023-70. Install with JIMS® No.1012-70TB.

No.25581-70 - Use on Big Twin 1970-99 single cam only. **(NOTE: Includes aftermarket engines.)**

No.25581-705 - Oversize +.005"

No.25581-80AB - Smaller I.D. is .9875". Use to repair out of center line cam cover.

### CAM BUSHING, IN CAM COVER

Standard O.D. is 1.0035". Install with JIMS® No.1011-36TB, remove with JIMS® No.2281.

No.25581-36 - Use on O.H.V. Big Twin 1936-69. **(NOTE: Includes aftermarket engines.)**



### CAM BUSHING

Sportster®, Buell®, 45", and Sidevalves. Standard O.D. is .9405". Install with JIMS® No.1017-37TB.

No.25586-37 - Use on Sportster® 1954-present.  
Use on Buell® 1987-present.  
Use on 45" 1937-73.  
Use on 74" and 80" Sidevalves 1937-48. **(NOTE: Includes aftermarket engines.)**

No.25586-375 - Oversize +.005"



### CAM BUSHING, IN RIGHT CASE

Standard O.D. is 1.0035". Install with JIMS® No.1011-36TB.

No.25597-36 - Use on Big Twin 1936-57.

No.25597-365 - Oversize +.005"



### CAM BUSHING REAR INTAKE

Sportster® - Standard O.D. is 1.3775".

No.25588-57 - Use on Sportster® 1957-90.

Use on Buell® 1987-90

No.25588-575 - Oversize +.005"



### STAKING PIN FOR STAKING BUSHINGS

Use on all bushings. These pins hold bushing in place. Use with JIMS® bushing installers drilling jigs. Sold in a pack of 10. Replaces H-D® No.275.

No.2201K - **(NOTE: Includes aftermarket engines.)**





## PINION SHAFT BUSHING

Standard O.D. is 1.0035".

Use JIMS® line reamer No.94805-57. Use the hole side of this bushing for motors 1954-72, for side feed oiling pinion shafts. Use the slotted side of this bushing for motors 1973-92 for end oiling pinion shafts. Remove with JIMS® No.95760-TP, Install with JIMS® No.1013-54TB.

No.25582-54/73 - Use on Big Twin 1954-92.

(NOTE: Includes aftermarket engines.)

No.25582-54/735 - Oversize +.005"



## PINION SHAFT BUSHING SMALL I.D.

Use JIMS® line reamer No.94805-57. I.D. is .5455". Must mill oil groove on side or drill hole. Use to repair out of centerline cam covers. Remove with JIMS® No.95760-TP.

No.25582-80AB - Use on Big Twin 1973-92.

(NOTE: Includes aftermarket engines.)



## PINION SHAFT CAM COVER BUSHING

End oiling. Standard O.D. is 1.0035". Use JIMS® line reamer No.94805-57. Remove with 95760-TP.

No.25582-93 - Use on Big Twin 1993-99 single cam only.

(NOTE: Includes aftermarket engines.)

No.25582-935 - Oversize +.005"



## PINION SHAFT BUSHING

Standard O.D. is .8775".

No.25593-57 - Use on Sportster® 1957-76.



## PINION SHAFT BUSHING

Standard O.D. is .815".

No.25593-74 - Use on Sportster® 1977-present.

Use on Buell® 1987-present.

(NOTE: Includes aftermarket engines.)

No.25593-745 - Oversize +.005"



## PINION SHAFT BUSHING

Standard O.D. is 1.0015". Install with JIMS® No.1018-37TB.

No.25582-36 - Use on Big Twin 1936-53.

No.25582-365 - Oversize +.005"



## IDLER AND CIRCUIT BREAKER GEAR BUSHING

No.25785-30A - Use on Big Twin 1932-69, and all Sidevalves 1930-73.

(NOTE: Includes aftermarket engines.)

# CRANK PINS

FRONT OF MOTOR RIGHT SIDE

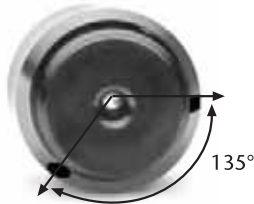

OIL HOLE TO KEY WAY

**BIG TWIN**  
**1941-EARLY 1981**



FRONT OF MOTOR RIGHT SIDE

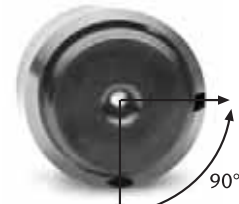



OIL HOLE TO KEY WAY

**BIG TWIN**  
**LATE 1981-PRESENT**  
**SINGLE CAM ONLY**

## CRANK PINS

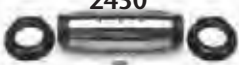

All crank pins are precision manufactured here in Camarillo, California. We start with a special order of steel from an American foundry, then saw, turn, mill, and grind all on numerical controlled machines. From sawing to the final phase of machining, each part is thoroughly inspected and after heat treating, all threads go through a special process to make them withstand greater torque stress. On crank pins, approximately 50% more torque can be applied. All flywheel shafts are ground to a 16 micron finish or better unless otherwise specified. All ground diameters are concentric to within .0003" or less, in order to simplify all phases of flywheel truing and rebuilding. We strongly recommend using JIMS® high performance nuts in combination with our crank pins.

### EARLY BIG TWIN MODELS - COMPLETE CRANK PIN KITS INCLUDES AFTERMARKET FLYWHEELS

Part No.	Year/ Application	Oiling Holes		O.D.	Crank Pin	Kit Includes: Crank Pin Nuts	Woodruff Key
		2	3				
 2429	Big Twin 1941-Early 81	X		1.2490"	1-23961-412	2-23966-54A	1-2186 (H-D® No.23985-18)
 2430	Big Twin 1941-Early 81		X	1.2490"	1-23961-413	2-23966-54A	1-2186 (H-D® No.23985-18)
 2438	Big Twin 1941-Early 81	X		1.2490"	1-23961-41 1"-20 threads	*2-23969-83	1-2186 (H-D® No.23985-18)

\*CAUTION! On pre-1956 models, check nut to case clearances.





### LATE BIG TWIN MODELS - COMPLETE CRANK PIN KITS INCLUDES AFTERMARKET FLYWHEELS

Part No.	Year/ Application	Oiling Holes		O.D.	Crank Pin	Kit Includes: Crank Pin Nuts	Woodruff Key
		2	3				
 2431	Big Twin single cam Late 1981-99	X		1.2495"	1-23961-80A2	2- 23969-83	1-2187 (H-D® No.11218)
 2432	Big Twin single cam Late 1981-99		X	1.2495"	1-23961-80A3	2- 23969-83	1-2187 (H-D® No.11218)





# CRANK PINS





## EARLY BIG TWIN MODEL CRANK PINS INCLUDES AFTERMARKET FLYWHEELS

Part No.	Year/Application	Oiling Holes			O.D.	Use with Nut	Use with Key
		1	2	3			
 23961-411	Big Twin 1941-Early 81	X			1.2490"	23966-54A	2186K
 23961-412	Big Twin 1941-Early 81		X		1.2490"	23966-54A	2186K
 23961-413	Big Twin 1941-Early 81			X	1.2490"	23966-54A	2186K
 23962-40	Big Twin 1937-52, O.H.V., 74" and 80" Sidevalves	X			1.250"	23966-36	2186K

## SPECIAL DESIGNS - EARLY BIG TWIN MODEL CRANK PINS INCLUDES AFTERMARKET FLYWHEELS

Part No.	Year/Application	Oiling Holes			O.D.	Use with Nut	Use with Key
		1	2	3			
 23961-41S	Big Twin 1941-Early 81			X	1.2490"	23966-54A	2186K
Special 180 degree oiling design that better lubricates your bearing diameter.							
 23961-41ST3	Big Twin 1941-Early 81			X	1.2490"	23966-54A	2186K
For the engine builder that likes less rod end play. This crank pin is ground .025" shorter from taper to taper.							

## LATE BIG TWIN MODEL CRANK PINS INCLUDES AFTERMARKET FLYWHEELS



Part No.	Year/Application	Oiling Holes		O.D.	Use with Nut	Use with Key
		2	3			
 23961-80A2	Big Twin single cam only Late 1981-99	X		1.2495"	23969-83	2187K
 23961-80A3	Big Twin single cam only Late 1981-99		X	1.2495"	23969-83	2187K
 23974-873	Big Twin single cam only Late 1981-99		X	1.2505" (Oversize +.001")	23969-83	2187K
 23975-873	Big Twin single cam only Late 1981-99		X	1.2515" (Oversize +.002")	23969-83	2187K

# CRANK PINS & ANTIQUE SHAFTS

## SPECIAL DESIGN - LATE BIG TWIN MODEL CRANK PINS INCLUDES AFTERMARKET FLYWHEELS

Part No.	Year/Application	Oiling Holes	O.D.	Use with Nut	Use with Key
	23961-80AS	3 Hole 180 Degree	1.2495"	23969-83	2187K
	Special 180 degree oiling design that better lubricates your bearing diameter.				

## 45" SPORTSTER & BUELL® MODEL CRANK PINS INCLUDES AFTERMARKET FLYWHEELS

Part No.	Year/Application	Oiling Holes			O.D.	Use with Nut	Use with Key
		1	2	3			
	23960-29	45" Models 1937-73	X			1.00"	2186K
	23960-54	Sportster 1954-81			X	1.250"	23967-54A 2186K
	23960-80A3	Sportster Late 1981-99 Buell 1987-99			X	1.250"	23901-81 2187K



### HARLEY DAVIDSON 1915-1936 CRANKPIN

Replaces H-D® No.'s 348-15 and 348-30.  
Standard O.D. is 1.000" - Thread is 13/16"-18.

No.348-15 - Use on 1915-36 61", 74" F, J, JD, VC,  
models.



### INDIAN SHAFTS DRIVE SHAFT

No.41043 - Use on 1933-48 Indian Chief.



### CRANK PIN

No.43067 - Use on 1933-53 Indian Chief.  
Use on 1933-42 Indian Sportscout.



### INDIAN NUTS PINION AND DRIVE SHAFT NUT

No.D180 - Use on 1933-53 Indian Chief.  
Use on 1928-42 Indian Sportscout.

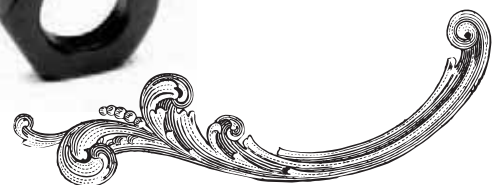



# NUTS

## JIMS® NUTS - THE ULTIMATE HOLDING POWER



In an increasing demand for quality and durability with crank pin, sprocket and pinion shaft nuts, we have been able to exceed our own high standards by maintaining the pitch diameter perpendicular to the face within .0002" (Which is 40% better than our previous .0005" tolerance!). Not only is this mandatory for pulling the shafts and crank pin straight into the flywheels, but it also ensures that both nut and flywheel faces are perfectly parallel, facilitating perfect contact. All of this translates into simplifying the truing process and maintaining essential flywheel integrity! All of our nuts are high performance CNC machined for uses ranging from stock motors, to top fuel and drag bike applications.

### CRANK PIN NUTS



(NOTE: CRANK PIN NUTS ARE SOLD IN A PACK OF 2)

	Part No.	Year/Application	Thread and Tool
 BIG TWIN	23966-36	Big Twin 74" O.H.V. 1936-52 Big Twin 80" Sidevalves 1937-48	7/8"-18
	23966-54A pictured	Big Twin 1954-81	1"-18 (Use with JIMS® No.1029-TS socket.)
 SPORTSTER	23969-83	Big Twin Single Cam Only Late 1981-99	1"-20 (Use with JIMS® No.1030-TS socket.)
	23967-54A	Sportster 1954-Early 1981	1"-20
	23901-81 pictured	Sportster 1954-81 and 1981-99, Buell® 1987-99 stroker motors. (Check for clearances.)	1"-20 (Use with JIMS® No.1033-TS and JIMS® No. 1039-TS sockets.)

### SPROCKET SHAFT NUTS

	Part No.	Year/Application	Thread	Sprocket Side	Flywheel Side
 BIG TWIN	24017-80 pictured	Big Twin - Use on JIMS® big tapered shafts. Use on all JIMS® 72" & 80" sprocket shafts. Check for rod clearance.	1-1/8"-16 (Use with JIMS® No.1032-TS socket.)		X
	24023-36	Big Twin 1930-70	3/4"-18		X
 BIG TWIN	24003-55 pictured	For belt drive & non-compensating sprockets. Use on 1955-06 FL, 1972-05, FX, FXR, FXD, 1984-06 FXST.	7/8"-14	X	

### PINION SHAFT NUTS

	Part No.	Year/Application	Thread	Gear Side	Flywheel Side
 BIG TWIN	24023-36 pictured	Big Twin 1930-Early 81 pinion shaft	3/4"-18		X
	24016-80	Big Twin Late 1981-89	3/4"-20 (Use with JIMS® No.1031-TS socket.)		X
 BIG TWIN	24022-90	Big Twin 1990-92	5/8"-24 left hand thread. (Use with JIMS® No.94555-55A socket to remove and install pinion nut.)	X	
	24023-54 pictured	Big Twin 1954-89		X	



## SPROCKET SHAFT HISTORY

The radius of the shoulder has been ground to a 16 or better finish to eliminate stress risers.

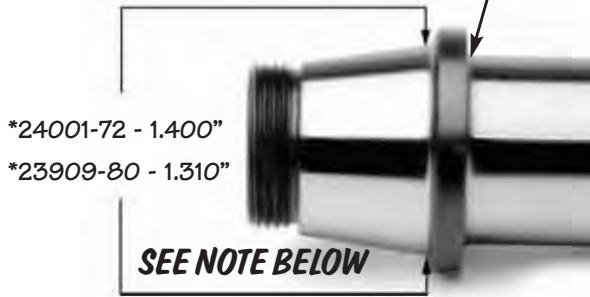

To help with the identification of Big Twin sprocket shafts, JIMS® would like to provide you with a little history into the design of the sprocket shaft. From first conception to approximately 1954, H-D® used a 6 degree taper on the flywheel side. In 1956, there was a change to 8-1/2° degrees, with a major diameter of about 1.060" at the largest end of taper. 1955 had a special sprocket shaft and flywheel, at 8-1/2° degrees, without a bearing shoulder on the shaft. The 8-1/2° degree x 1.060" taper lasted until 1972. It retained the 8-1/2° degree taper, but was increased in size to about 1.400" at the biggest part of the taper. This shaft also used a bigger nut, 1-1/8" -16, and the flywheels still used a nut locking plate and screw until early 1981.

In late 1981 they became what H-D® called the "communized" taper, which is the old 6 degree, but with a size of about 1.310" at the largest part of taper. The flywheel side nut has the same thread at 1-1/8" -16, but the flywheels do not have a screw hole for a locking plate.

**\*NOTE:** All (-72) and (-80) sprocket shafts will have one of the above diameters. You can also check flywheels for this diameter to determine the right sprocket shaft for your application.

## PINION SHAFT HISTORY

The first non-splined, (tapered with key) pinion shaft was introduced in 1954. Taper was 6 degrees on flywheel side.

This remained the same until 1990 with the introduction of the integral shaft flywheels.

- 1954-72 Pinion shafts had the oil hole in flywheel and shaft, 135 degrees to the key (side oiler hole design).
- 1973 Was the first year of constant oil flow to the crank pin oil hole in flywheel and shaft, 135 degrees to the key (end oiler design).
- 1981-89 Pinion shaft was communized taper design. Oil hole in flywheel and shaft 90 degrees to the key (end oiler design).
- 1954 - Early 1981 has 3/4 - 18 thread on flywheel side.
- Late 1981-89 has 3/4 - 20 thread on flywheel side.

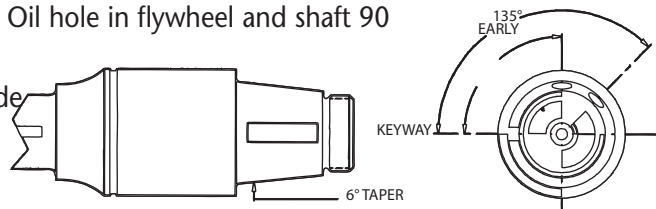

All sprocket and pinion shafts are precision manufactured here in Camarillo, California. We start with a special order of steel from an American foundry then saw, turn, mill, and grind all on numerically controlled machines. From sawing to the final phase of machining, each part is thoroughly inspected. After heat treating, all threads go through a special process to make them withstand greater torque stress. On big threaded sprocket shafts, approximately 50% more torque can be applied. All flywheel shafts are ground to a 16 micron finish or better unless otherwise specified. All ground diameters are concentric to within .0003" or less, to simplify all phases of flywheel truing and rebuilding. We strongly recommend using JIMS® high performance nuts.

### THE FOLLOWING IS A QUOTE FROM THE HARLEY-DAVIDSON® SERVICE MANUAL

*When truing the flywheels the number of blows required, and how hard they should be struck depends on how far shafts are out of true, and how tight nuts are drawn. Always remove the flywheels from the stand and strike the flywheel rim at 90° to the crank pin. Use only a soft metal mallet. Never strike wheels while in truing stand. This could result in a broken pinion shaft or other parts and tools.*





# SPROCKET SHAFTS

## BIG TWIN SPROCKET SHAFTS

Part No.	Year/ Application	Product Details	Use with Nut		Use with Key
			Sprocket Side	Flywheel Side	
24001-30	Big Twin 1930-54, also use on 74" and 80" Sidevalves 1937-48		JIMS® 24003-30	JIMS® 24023-36	JIMS® 2488
24001-56	Big Twin 1956-64	This shaft is 3.51" long from bearing shoulder to end of small thread. Taper is 8-1/2°.	JIMS® 24003-55	JIMS® 24023-36	JIMS® 2489
24001-65	Big Twin 1965-69	This shaft is 3.750" long from bearing shoulder to end of small thread. Taper is 8-1/2°.	JIMS® 24003-55	JIMS® 24023-36	JIMS® 2489
24001-70	Big Twin 1970-71	This shaft is 4.262" long from bearing shoulder to end of small thread. Taper is 8-1/2°.	JIMS® 24003-55	JIMS® 24023-36	JIMS® 2489
24001-72	Big Twin 1972-81. Sprocket shaft does not have keyway.	This shaft is 4.262" long from bearing shoulder to end of small thread. Taper is 8-1/2°. The biggest part of the taper is approximately 1.400".	JIMS® 24003-55	JIMS® 24017-80	N/A
23909-80	Big Twin Late 1981-Early 1985 for H-D® flywheels & all aftermarket flywheels, single cam only	Has keyway for aftermarket flywheels, 4.262" long from bearing shoulder to end of small thread. Taper is 6°. Biggest part of taper will be approximately 1.310" on all 80" Big Twin sprocket shafts.	JIMS® 24003-55	JIMS® 24017-80	JIMS® 2489



## 45" MODELS & SPORTSTER SPROCKET SHAFTS

	Part No.	Year/Application	Flywheels		Use with Nut		Use with Key
			H.D.	Others	Sprocket Side	Flywheel Side	
	24000-29	45" Models 1929-73	X	X	H-D® 7991	H-D® 7974	JIMS® 2488
	24000-57	Sportster 1957-76	X	X	H-D® 40387-70	H-D® 8011	JIMS® 2488
	24000-75	Sportster 1977-Early 1981	X	X	H-D® 40387-70	H-D® 8011	JIMS® 2488
	24000-80	Sportster Late 1981-85	X	X	H-D® 40387-70	H-D® 23902-81	N/A

# PINION SHAFTS

## BIG TWIN PINION SHAFTS

Part No.	Year/ Application	Product Details	Oiling		Use with Key		Use with Nut	
			End	Side	Pinion Gear Side	Flywheel Side	Pinion Gear Side	Flywheel Side
24007-39	Big Twin 1939-53	Standard O.D. is 1.000" 24020-51 screw included		X		JIMS® 2488	N/A	JIMS® 24023-36
24006-54A	Big Twin 1954-57	Plug #2197 included		X	JIMS® 2480	JIMS® 2488	JIMS® 24023-54	JIMS® 24023-36
24006-58	Big Twin 1958-72	Plug #2197 included		X	JIMS® 2480	JIMS® 2488	JIMS® 24023-54	JIMS® 24023-36
24006-73	Big Twin 1973-81	Includes Aftermarket Engines	X		JIMS® 2480	JIMS® 2488	JIMS® 24023-54	JIMS® 24023-36
24006-80/83	Big Twin 1981-86	Metered oil screw jet included No.2196	X		2480	JIMS® 2187	JIMS® 24023-54	JIMS® 24016-80
					2483 Oil Pump			
24006-83L	Big Twin	John Harman's big bore engine case and other CAM offset cases like Delkron cases. Measures .370" longer.	X		2480	JIMS® 2187	JIMS® 24023-54	JIMS® 24016-80
					2483 Oil Pump			
24006-87	Big Twin 1987-99	Use with 1987-99 single cam pinion bearing. Metered oil screw jet included No.2196	X		JIMS® 2483	JIMS® 2187	JIMS® 24023-54	JIMS® 24016-80
2439	Big Twin	Special application (cam case offset 1/4"). Same as JIMS® No.2437, but 1/4" longer, includes metered oil screw jet No.2196. (See No.2437 for more information)	X		2480	JIMS® 2187	JIMS® 24023-54	JIMS® 24016-80
					2483 Oil Pump			
2437	Big Twin 1987-99	Same as JIMS® shaft No.24006-80/83 but has a longer bushing nose for use with H-D® 1993 cam cover and JIMS® cam cover No.25254-93A. Also has a larger oil pump drive key slot. Pinion shaft designed for use with aftermarket stroker flywheels. Use with JIMS® pinion gears and oil pump drive gear. Can also be used with JIMS® pinion bearing assembly, see index for bearing listings. Shaft includes a metered oil screw jet No.2196 installed.			JIMS® 2480	JIMS® 2187	JIMS® 24023-54	JIMS® 24016-80
					JIMS® 2483 Oil Pump			



## 45", SPORTSTER, 74" AND 80" SIDE VALVE PINION SHAFTS

Part No.	Year/ Application	Product Details	Oiling		Use with Key	Use with Nut	
			Side	End		Pinion Gear Side	Flywheel Side
24005-37	45" Models 1937-73	Plug #2197 included	X		JIMS® 2488	N/A	H-D® 7974
24006-37	74" and 80" Sidevalves 1937-48	Left hand screw included, No. 24020-51	X		JIMS® 2488	N/A	JIMS® 24023-36
24005-57	Sportster 1957-76			X	JIMS® 2488	N/A	H-D® 8011
24005-80	Sportster 1981-85	Bearing diameter is 1.2482"		X	JIMS® 2187	H-D® 7913	H-D® 23902-81





# SPROCKET/PINION SHAFT KITS & SPACERS



### KIT INCLUDES:

- 1 - 24006-73, Pinion shaft
- 1 - 24023-36, Flywheel side nut
- 1 - 24023-54, Pinion side nut
- 1 - 2488, Flywheel key, Rep.23985-12
- 2 - 2480, Gear keys, Rep.23985-54
- 2 - 2482, Washers, Rep.24692-58
- 1 - 2481, Retaining ring, Rep.11007

**BIG TWIN 1973-81.** Same shaft as No.24006-73 (End oiling) pinion bushing.



### KIT INCLUDES:

- 1 - 24006-80/83, Pinion shaft
- 1 - 2196, Metered oil jet screw
- 1 - 24016-80, Flywheel side nut
- 1 - 2187, (H-D® No.11218), Flywheel side key
- 1 - 2480, (H-D® No.23985-54), Pinion gear key
- 1 - 2481, (H-D® No.11007), Retainer
- 2 - 2482, (H-D® No.24692-58), Washers
- 1 - 24023-54, Pinion Nut
- 1 - 2483, (H-D® No.26348-15), Oil pump drive gear key

**BIG TWIN 1981-EARLY 1986.** End oiling. (**NOTE:** Fits aftermarket and S&S® engines.) Use with H-D® flywheels 1981-Early 1986 or aftermarket flywheels with common taper design. This flywheel assembly can then be used in Big Twin 1973-92.

### BIG TWIN SPROCKET SHAFT KIT (Kit includes nuts and key)

	Part No.	Year/Application	Sprocket Shaft	Nuts		Key
				Sprocket Side	Flywheel Side	
	2433	Big Twin Late 1981-Early 1985 for H-D® flywheels & all aftermarket flywheels, single cam only	JIMS® 23909-80	JIMS® 24003-55	JIMS® 24017-80	JIMS® 2489

14



### SPROCKET SHAFT SPACER KIT

Use on Big Twin 1955-69. Spacers are machined to a 32 finish, and burr free for extended seal life. Made to fit the rubber sprocket shaft oil seal. This kit contains the following. **Spacers NOT sold separately.**

.336" Wide .516" Wide .546" Wide .574" Wide  
 .606" Wide .621" Wide .636" Wide .666" Wide  
 No.24029-KIT - Includes one of each of the above. Complete kit only.  
 Spacers NOT Sold Separately.



### SPROCKET SHAFT OIL SEAL SPACER

Spacers are machined to a 32 micron finish, and burr free for extended seal life. Use JIMS® tool No.39361-69 to install seal.

No.24002-70 - Use on single cam Big Twin 1970-99.  
 (**NOTE:** Includes aftermarket engines.)



### PINION GEAR SPACER

Quality replacement spacer for stock or aftermarket engines. (Use with matching JIMS® gear No.26349-84 or equivalent)

No.24703-54B - Use on Big Twin 1954-1989.

# PINION SHAFT HARDWARE, IDLER & CIRCUIT BREAKER SHAFTS & RETAINERS



## OIL METERING JET SCREW (WITH HOLE)

Use on JIMS® No.24006-80/83 and No.24006-87 Pinion Shafts. Use as needed for oil control to rod rollers with hole size of .087" (One included with JIMS® No.24006-87 & 24006-80/83). **Sold in a pack of 10.**

No.2196K - Oil metering screw



## PINION SHAFT PLUG (NO HOLE)

Replacement plug for JIMS® pinion shafts No. 24005-37, 24006-54A and 24006-58. 1 plug included with these shafts. Use only with side oiler shafts. **Sold in a pack of 10.**

No.2197K - Oil plug

**CAUTION: USING A "NO HOLE" PLUG IN A PINION SHAFT 1973-PRESENT WILL SHUT OFF OIL TO CONNECTING RODS, WHICH WILL RESULT IN ENGINE DAMAGE.**



## PINION GEAR SHAFT SCREWS

Left hand screws for early pinion shafts. **Sold in a pack of 10.**

No.24020-51K - Use on pinion shaft No.24006-37 and No.24007-39.



## PINION BEARING RETAINER

Use with steel bearing retainers and JIMS® bearings, See page 86 and 87 for bearings. Replaces H-D® No.11007. **Sold in a pack of 10.**

No.2481K - Use on Big Twin 1958-86, may also be used on 1986-1999 single cam only when using the right bearings and retainers. **(NOTE: Includes aftermarket engines.)**



## CIRCUIT BREAKER SHAFT

No.25856-36 - Use on Big Twin 1936-69.

**(NOTE: Includes aftermarket engines.)**



## CIRCUIT BREAKER SHAFT & BUSHING KIT

Kit includes: 1 - 25856-36 shaft, 2 - 25785-30A bushings.

No.25856-KIT - Use on Big Twin 1936-69.

**(NOTE: Includes aftermarket engines.)**



## IDLER SHAFT AND BUSHING KIT

No.25791-KIT - Use on Big Twin 1936-69.

**(NOTE: Includes aftermarket engines.)**



## IDLER GEAR SHAFT

No.25791-36 - Use on Big Twin 1936-69.

**(NOTE: Includes aftermarket engines.)**



## PINION BEARING WASHERS

Use with steel bearing retainers. **Sold in a pack of 5.** Replaces H-D® No.24692-58.

No.2482K - Use on Big Twin 1958-86, may also be used on 1986-1999 single cam only when using the right flywheels and pinion shafts. **(NOTE: Includes aftermarket engines.)**



## SPROCKET & PINION SHAFT KEY

Sprocket & pinion shaft flywheel key. Replaces H-D® No.23985-12. Sold in a pack of 10.

No.2488K - Use on all Big Twins 1912-80 pinion shafts. Use on all Big Twins 1912-55 sprocket shafts. (**NOTE:** Includes aftermarket engines.)



## SPROCKET SHAFT KEY

Sprocket shaft flywheel key. Replaces H-D® No.23985-56. Sold in a pack of 10.

No.2489K - Use on all Big Twin 1956-present single cam only sprocket shafts, or when using aftermarket flywheels. (**NOTE:** Includes aftermarket engines.)



## CRANK PIN KEY EARLY

Early crank pin key. Use on crank pins No.23960-29, 23960-54, 23961-41 & 23962-40. Replaces H-D® No.23985-18. Sold in a pack of 10.

No.2186K - Use on Big Twin Late 1941- Early 1981. (**NOTE:** Includes aftermarket engines.)



## CRANK PIN & PINION SHAFT KEY LATE

Late crank pin & pinion shaft key. Use on crank pins No.23960-80 & 23960-81. Sold in a pack of 10. Replaces H-D® No.11218.

No.2187K - Use on Big Twin crank pins late 1981-present single cam only. Use on Sportster® crank pins late 1981-1999. Use on Buell® crank pins 1987-1999. Use on Big Twin pinion shafts late 1981-89 and all aftermarket flywheels. Use on Sportster® pinion shafts late 1981-85. (**NOTE:** Includes aftermarket engines.)



## PINION GEAR KEY

Replaces H-D® No.23985-54. Sold in a pack of 10.

No.2480K - Use 2 keys on Big Twin 1954-Early 75. Use 1 key for pinion gear Late 1975-89. (**NOTE:** Includes aftermarket engines.)



## OIL PUMP DRIVE SHAFT KEY

Replaces H-D® No.26348-15. Sold in a pack of 10.

No.2483K - Use 2 keys on Big Twin pinion and oil pump drive gear Late 1975-89. Use 3 keys on Big Twin oil pump drive shaft 1968-present single cam only. Use 2 keys on Big Twin oil pump drive shaft 1936-67. Use on K models 1952-59. Use on Sportster® models 1972-76. (**NOTE:** Includes aftermarket engines.)



# PINION GEARS

JIMS® pinion gears are made with the finest American aerospace quality tool steel. Precision machined to exact tolerances with no compromises in workmanship.

JIMS® offers eight different sizes of early gears and seven sizes of the late style gears, providing you with the perfect fit for any cam gear fitment job. This cam gear fitment is essential to quiet valve train operation. Too loose of a fit will result in a clicking noise, sometimes confused with lifter noise, and too tight of a fit will produce a severe gear whine.

No matter what situation, use a gear you can depend on and one that's backed by over 44 years of manufacturing experience. For quality known world wide, use...JIMS®.



JIMS® RECOMMENDS:	
PART NO.	DESCRIPTION
1110	GAUGE PINS
1111	GAUGE PINS
2237	LOCKER TOOL
96830-51	PULLER
94555-55A	NUT SOCKET

## PINION GEAR

Use on Big Twin 1954-Early 1977. (**NOTE:** Includes aftermarket engines.)

ORDER NO.	GEAR SIZE OVER .105 PINS	CAM GEAR OVER .105 PINS	COLOR CODE
No.24010-OR	1.4490-1.4485	2.7665-2.767	Orange
No.24010-RE	1.4480-1.4475	2.7675-2.768	Red
No.24010-BLU	1.4475-1.447	2.768-2.7685	Blue
No.24010-GR	1.4470-1.4465	2.7685-2.769	Green
No.24010-WH	1.4465-1.446	2.769-2.7695	White
No.24010-BR	1.4460-1.4455	2.7695-2.770	Brown
No.24010-YE	1.4455-1.445	2.770-2.7705	Yellow



## PINION GEAR

Use on Big Twin Late 1977-1989. (**NOTE:** Includes aftermarket engines.)

ORDER NO.	GEAR SIZE OVER .105 PINS	CAM GEAR OVER .105 PINS	COLOR CODE
No.24040-78	1.4751-1.4756	2.7324-2.7334	Orange
No.24041-78	1.4745-1.4751	2.7334-2.7344	White
No.24042-78	1.4737-1.4745	2.7344-2.7354	Yellow
No.24043-78	1.4729-1.4737	2.7354-2.7364	Red
No.24044-78	1.4721-1.4729	2.7364-2.7374	Blue
No.24045-78	1.4715-1.4721	2.7374-2.7384	Green
No.24046-78	1.4710-1.4715	2.7384-2.7394	Black



## ROD ROLLERS FOR BIG TWIN FEMALE ROD

These are the best rollers to use for longer motor life. Why? These rollers are made in the U.S.A. to JIMS® specs from aerospace quality 52100 bearing material. Standard O.D. is .1875", and a length of .325". Use JIMS® No.24336-51K retainers on 1941-present single cam only or any Big Twin using a 1-1/4" crank pin. **Sold in packs of 100 pcs.** (NOTE: Includes aftermarket engines.)

JIMS® NO.	SIZE	O.D. SIZE	H-D® NO.
No.2440	Std. O.D.	O.D. is .1875"	9101A
No.2442	+.0004"	O.D. is .1879"	9103A
No.2443	+.0006"	O.D. is .1881"	9104A
No.2444	+.0008"	O.D. is .1883"	9105A
No.2445	+.001"	O.D. is .1885"	9106A
No.2446	+.002"	O.D. is .1895"	
No.2447	+.003"	O.D. is .1905"	



## ROD ROLLERS BIG TWIN MALE ROD

Note: Male rollers are longer in length than female rollers. Standard O.D. is .1875", and a length of .660". Use JIMS® No.24366-51K retainers on 1941-present single cam only or any Big Twin using a 1-1/4" crank pin. **Sold in packs of 100 pcs.** (NOTE: Includes aftermarket engines.)

JIMS® NO.	SIZE	O.D. SIZE	H-D® NO.
No.2448	Std. O.D.	O.D. is .1875"	9171A
No.2449	+.0002"	O.D. is .1877"	9172A
No.2450	+.0004"	O.D. is .1879"	9173A
No.2451	+.0006"	O.D. is .1881"	9174A
No.2452	+.0008"	O.D. is .1883"	9175A
No.2453	+.001"	O.D. is .1885"	9176A
No.2454	+.002"	O.D. is .1895"	
No.2455	+.003"	O.D. is .1905"	



## CONNECTING ROD BEARING SETS FOR SINGLE CAM BIG TWINS

These American made Torrington® rod bearing sets consisting of three packaged bearings with 16 rollers in steel cages. They will retro fit back to 1941. They are available in a standard size only. When refitting rods, use this set with JIMS® oversize crankpins.

No.3999 - Use on 1941-99, Single Cam Big Twin Motors. Replaces H-D®No.24346-87A. (NOTE: Includes aftermarket engines.)



## ROD ROLLER RETAINERS 18 ROLLERS IN EACH

Made from billet steel. Sold in a pack of 4.

No.24366-51K - Use on Big Twin 1941-99 single cam only. (NOTE: Includes aftermarket engines.) Use with rollers listed above.

**THESE RETAINERS ARE MADE FROM 1144 STRESS PROOF BILLET STEEL. THEY ARE THE ULTIMATE IN ROD ROLLER RETAINERS.**

# ROLLER BEARING



## ROD ROLLERS FOR BIG TWIN MALE ROD

These rollers are made in the USA to JIMS® specifications from aerospace quality 52100 bearing material.

Use on Big Twin 1973-86 with aluminum cages. Standard bearing O.D. is .1875" x .590" long.

Sold in packs of 100 pcs.

(NOTE: Includes aftermarket engines.)

JIMS® NO.	SIZE	O.D. SIZE
No.9180	+ .0002"	O.D. is .1877"
No.9181	+ .0004"	O.D. is .1879"
No.9182	+ .0006"	O.D. is .1881"
No.9183	+ .0008"	O.D. is .1883"
No.9184	+ .0010"	O.D. is .1885"
No.9186A	+ .0020"	O.D. is .1895"
No.9186AA	+ .0030"	O.D. is .1905"
No.9185	- .0002"	O.D. is .1873"



## ROD ROLLERS FOR SPORTSTER® MALE ROD

These rollers are made in the USA to JIMS® specifications from aerospace quality 52100 bearing material.

Use on Sportster® 1954 - 86 with aluminum cages. Standard bearing O.D. is .1875" x .480" long. Sold in packs of 100 pcs.

(NOTE: Includes aftermarket engines.)

JIMS® NO.	SIZE	O.D. SIZE
No.9150A	STD. O.D.	O.D. is .1875"
No.9152A	+ .0002"	O.D. is .1877"
No.9154A	+ .0004"	O.D. is .1879"
No.9156A	+ .0006"	O.D. is .1881"
No.9158A	+ .0008"	O.D. is .1883"
No.9160A	+ .0010"	O.D. is .1885"
No.9417	+ .0020"	O.D. is .1895"
No.9150AA	+ .0030"	O.D. is .1905"
No.9161	- .0002"	O.D. is .1873"



## ROD ROLLERS FOR BIG TWIN AND SPORTSTER®, FEMALE ROD

These rollers are made in the USA to JIMS® specifications from aerospace quality 52100 bearing material.

Use on Sportster® 1954-86 with aluminum cages. Use on Big Twin 1973-86 with aluminum cages. Standard bearing O.D. is .1875 x .290" long.

Sold in packs of 100 pcs.

(NOTE: Includes aftermarket engines.)

JIMS® NO.	SIZE	O.D. SIZE
No.9441A	STD. O.D.	O.D. is .1875"
No.9442A	+ .0002"	O.D. is .1877"
No.9443A	+ .0004"	O.D. is .1879"
No.9444A	+ .0006"	O.D. is .1881"
No.9445A	+ .0008"	O.D. is .1883"
No.9446A	+ .0010"	O.D. is .1885"
No.9418	+ .0020"	O.D. is .1895"
No.9441AA	+ .0030"	O.D. is .1905"
No.9450A	- .0002"	O.D. is .1873"



## RIGHT CASE PINION SHAFT ROLLERS, BIG TWIN 1955-1957

## RIGHT CASE PINION SHAFT ROLLERS, SPORTSTER® 1957-1976

These rollers are made in the USA to JIMS® specifications from aerospace quality 52100 bearing material.

Standard bearing O.D. is .1875" x .800" long.

Sold in packs of 100 pcs.

(NOTE: Includes aftermarket engines.)

JIMS® NO.	SIZE	O.D. SIZE
No.9422	+ .0002"	O.D. is .1877"
No.9423	+ .0004"	O.D. is .1879"
No.9424	+ .0006"	O.D. is .1881"
No.9425	+ .0008"	O.D. is .1883"
No.9426	+ .0010"	O.D. is .1885"



# ROLLER BEARINGS



## ROLLER BEARINGS

- Right Case Pinion Shaft Roller, Big Twin 1958-86
- Left Case Sprocket Shaft Rollers, Big Twin 1930-57
- Front & Rear Wheels, All Twins 1925-67

These rollers are made in the USA to JIMS® specifications from aerospace quality 52100 bearing material.

Standard bearing O.D. is .250" x .490" long.  
Sold in packs of 100 pcs.

(NOTE: Includes aftermarket engines.)

JIMS® NO.	SIZE	O.D. SIZE
No.9221A	+.0002"	O.D. is .2502"
No.9222A	+.0004"	O.D. is .2504"
No.9223A	+.0006"	O.D. is .2506"
No.9224A	+.0008"	O.D. is .2508"
No.9225A	+.0010"	O.D. is .2510"
No.9220AA	+.0020"	O.D. is .2520"

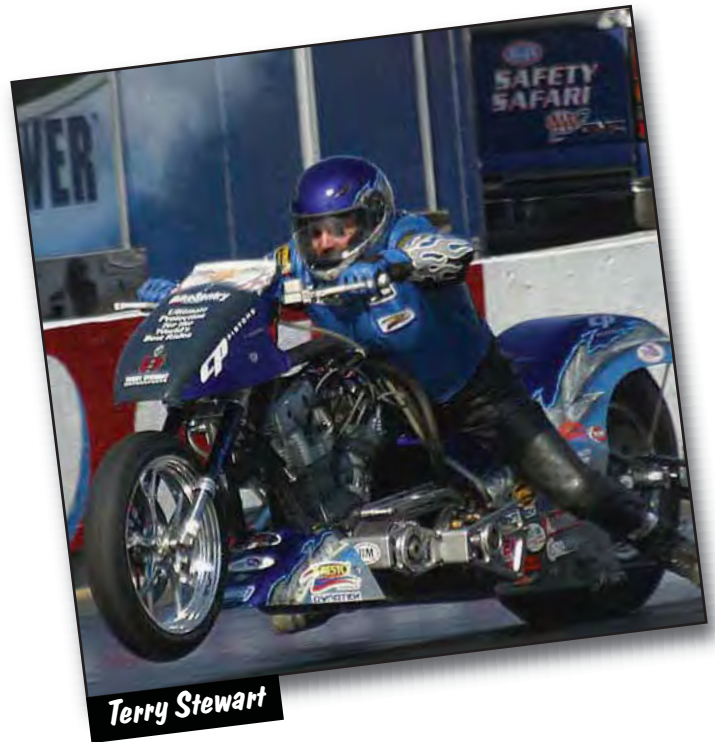

## PINION SHAFT BEARINGS BIG TWIN

Use on Big Twin 1987 - 99 single cam only. Use these bearings with JIMS® Pinion Shaft No.2437. For H-D® flywheels 1981-86 and some aftermarket flywheels. Some aftermarket flywheels may need bearing washers for centering this bearing onto the bearing journal. If no outer bearing washer is used, use H-D® No.11177A snap ring for retaining bearing to pinion shaft. Overall length of bearing is 1.280". (NOTE: Includes aftermarket engines.)

JIMS® NO.	COLOR	BEARING O.D. X 2	PINION SHAFT O.D.	EXAMPLE OF LAPPED CASE RACE I.D.	EXAMPLE OF BEARING ON PINION SHAFT RUNNING FIT	
					High	Low
24628-87	Green	.2502" x 2 = .5004"	1.2500" ±.0002"	1.7508"/1.7515"	.0009"-.0013"	.0002"-.0006"
24626-87	White	.2503" x 2 = .5006"	1.2500" ±.0002"	1.7510"/1.7517"	.0009"-.0013"	.0002"-.0006"
24641-87	Red	.2504" x 2 = .5008"	1.2500" ±.0002"	1.7512"/1.7519"	.0009"-.0013"	.0002"-.0006"
24643-87	Blue	.2505" x 2 = .5010"	1.2500" ±.0002"	1.7514"/1.7521"	.0009"-.0013"	.0002"-.0006"

The list of examples are a reference starting point. Be sure to follow H-D® Service Manual specifications.



## BIG TWIN BEARING RACE

With locking detents.

Right Case - Standard O.D. is 2.1270"

- No.24599-58 - Use on Big Twin 1958-78.  
 (NOTE: Includes aftermarket engines.)  
 No.24600-58 - Oversize +.002".  
 No.24601-5810 - Oversize +.010".  
 No.24601-5832 - Oversize +.032".



## BIG TWIN BEARING RACE

- Right Case Standard O.D. is 2.1270" - 360° oiling hole  
 No.24599-58B - Use on Big Twin 1993-99 single cam.  
 (NOTE: Includes aftermarket engines.)  
 No.24600-58B - Oversize +.002".  
 No.24601-58B10 - Oversize +.010".  
 No.24601-58B32 - Oversize +.032".



## BIG TWIN BEARING RACE

Without locking detents.

Right Case - Standard O.D. is 2.1270"

- No.24599-58A - Use on Big Twin 1979-92.  
 (NOTE: Includes aftermarket engines.)  
 No.24600-58A - Oversize +.002".  
 No.24601-58A10 - Oversize +.010".  
 No.24601-58A32 - Oversize +.032".



## BIG TWIN BEARING RACE

- Left Case Standard O.D. is 2.0015"  
 No.24621-40 - Use on 74" and 80" Big Twin 1940-54. Use on 74" and 80" Sidevalves 1940-48.  
 No.24623-40 - Oversize +.005".  
 No.24623-4032 - Oversize +.032".



## BIG TWIN SV BEARING RACE

Right Case - Standard O.D. is 2.0015"

- No.24595-40 - Use on 74" and 80" Sidevalves 1940-48.  
 No.24597-40 - Oversize +.005".



## 45" BEARING RACE

- Left Case Standard O.D. is 1.753"  
 No.24610-39 - Use on 45" 1939-73.  
 No.24612-39 - Oversize +.005".



## 45" BEARING RACE

- Right Case standard O.D. is 1.753"  
 No.24585-39 - Use on 45" 1939-73 Right Case.  
 No.24587-39 - Oversize +.005".



## BIG TWIN BEARING RACE

- Right Case - Standard O.D. is 2.0015"  
 No.24599-40 - Use on Big Twin 1940-54.  
 No.24601-40 - Oversize +.005".



## SPORTSTER, K BEARING RACE

Right Case - Standard O.D. is 1.7515"

- No.24585-57 - Use on Sportster® and K model 1954-76.  
 No.24585-575 - Oversize +.005"



## BIG TWIN BEARING RACE

- Right Case - Standard O.D. is 2.0015"  
 No.24599-55 - Use on Big Twin 1955-57.  
 No.24601-55 - Oversize +.005".

# ROD RACES & BUSHINGS



## ROD RACES

Made from 52100 aerospace quality Timken® bearing stock. **Sold in a set of 3.**

No. **1025-15** - Use on 1915-36 61" and 74" - F, J, JD, VC, VL, VE, VLD, and VLH.



## ROD RACES

Made from 52100 aerospace quality Timken® bearing stock. **Sold in a set of 3.** Replaces H-D® No.24345-36A female rod race, and No.24356-36A male rod race. I.D. is 1.622", Std. O.D. is 1.8195".

No. **1046-36A** - Use on Big Twin 1941-99 single cam only.

**(NOTE: Includes aftermarket engines.)**



## PISTON PIN BUSHING

Twin Cam® Bushings are **Sold in packs of 2.** For removal and installation, use JIMS® tool No.1051. To ream to correct size, use JIMS® No.1726-3 wrist pin reamer. Bushing O.D. is 1.017"±.0005, I.D. is .927", replaces No.24316-99.

No. **3998K** - Use on all Twin Cam® 1999-2006 FL, FXD, 2000-2006 FXST.



## PISTON PIN BUSHING

Bushings are **Sold in a pack of 2.** Big Twin - Standard O.D. is .8955". Ream with JIMS® No.1726-1, remove and install with JIMS® No.95970-32C.

No. **24334-36** - Use on Big Twin 1936-99 single cam. **(NOTE: Includes aftermarket engines.)**

No. **24335-36** - Oversize +.005".



## PISTON PIN BUSHING

Bushings are **Sold in a pack of 2.** Ream with JIMS® No.1726-2. Remove and install with JIMS® tool No.95970-32C. Sportster® and 45"- Standard O.D. is .8955".

No. **24331-36** - Use on Sportster® and 45" 1936-present. Use on Buell® 1987-present.

**(NOTE: Includes aftermarket engines.)**

RECOMMENDED JIMS® ROD TOOLS	
PART NO.	DESCRIPTION
1003	Rod Race remover/installer
96740-36	Rod Lapping set
1051	Rod Bushing
96920-32C	Rod Bushing
1284	Rod Holder
1148	Rod Alignment
1010	Rod Alignment
1158	Rod Alignment
1726-1	Pin Bushing Reamer
1726-2	Pin Bushing Reamer
1726-3	Pin Bushing Reamer





## JIMS® FULLY CNC MACHINED BILLET OIL PUMP ASSEMBLIES

### FEATURES:

- This Flow Pro 1 will give an increase in oil return (scavenge) volume over stock pumps, thus increasing horsepower by decreasing drag on the flywheels and other rotating parts.
- Choice of end cover for custom or stock oil line connections.
- Cover and body are polished Billet, or OEM style black wrinkle finish 6061-T651 Aluminum CNC machined to exact tolerances for strong, more durable and wear resistant oil pumps.
- “Matched” Feed and Return gears, individually “Matched” to each body. (See page 92)
- Available for late 1973-present Single Cam Big Twins, use on 74" to 140" motors. 1981-present bolts on with no modification. **NOTE:** 1973-80 cases will require a simple drilling for oil drain hole.
- No provisions for front or rear chain oiling.
- Oil pumps are supplied with late style, 1/4"-20 mounting hardware only.

For more details see No.1752-IS instructions.



**BOTTOM FEED**

**TOP FEED**

16

PART NO.	APPLICATION	FINISH	FEED POSITIONS
No.1754	Big Twin 1973-91	Polished	Top
No.1754B	Big Twin 1973-91	Black	Top
No.1753	Big Twin 1992-99	Polished	Bottom
No.1753B	Big Twin 1992-99	Black	Bottom
No.1755	Big Twin 1973-91	Polished	Bottom
No.1755B	Big Twin 1973-91	Black	Bottom
No.1752	Big Twin 1992-99	Polished	Top
No.1752B	Big Twin 1992-99	Black	Top

RECOMMENDED JIMS® TOOLS FOR OIL PUMP SERVICE	
PART NO.	DESCRIPTION
No.1053	Oil pump seal installer
No.1052	Oil pump snap ring installer
No.2361	Dental pick

### IMPORTANT NOTICE

Chrome plating is not recommended by JIMS®. The chroming process and contaminants are very sensitive to the oil pump, therefore JIMS® voids all warranty if the pump is plated.

**NOTE:** Oil Pumps are supplied with late style, 1/4"-20 mounting hardware only.

## JIMS® FULLY CNC MACHINED BILLET OIL PUMPS

This Flow Pro 1 will give an increase in oil return (scavenge) volume over stock pumps.

### Features:

- Increase horsepower by decreasing drag on the flywheels and other rotating parts.
- Polished, or OEM style black wrinkle Billet 6061-T651 Aluminum. CNC machined to exact tolerances for the strongest, most durable, wear resistant oil pumps.
- "Matched" Feed and Return gears, individually "Matched" to each body.

Available for late 1973-present Big Twins, use on 74" to 140" motors. 1981- present bolts on with no modification. **NOTE:** 1973-80 cases will require a simple drilling. (for oil drain hole)

For more details see No.1711-IS instructions.

No.1711E - Polished Oil Pump Body, Use on Big Twin 1973-91.

No.1711EB - Black Oil Pump Body, Use on Big Twin 1973-91.

No.1711L - Polished Oil Pump Body, Use on single cam Big Twin 1992-99.

No.1711LB - Black Oil Pump Body, Use on single cam Big Twin 1992-99.



**NOTE:** See tools for oil pump work on previous page.

**NOTE:** No provision in the cover for front or rear chain oiling.



### POLISHED & BLACK WRINKLE BILLET OIL PUMP COVER (BOTTOM FEED)

Designed with late oil pressure relief enabling return of excess oil to feed side of oil pump. Use with all aluminum oil pump bodies. (**NOTE:** No provision in the cover for front or rear chain oiling).

No.1698E - Polished, Use on JIMS® billet oil pump bodies and Big Twin 1973-91.

No.1698EB - Black, Use on JIMS® billet oil pump bodies and Big Twin 1973-91.

No.1698L - Polished, Use on JIMS® billet oil pump bodies and Big Twin 1992-99.

No.1698LB - Black, Use on JIMS® billet oil pump bodies and Big Twin 1992-99.

#### IMPORTANT NOTICE

Chrome plating is not recommended by JIMS®. The chroming process and contaminates are very sensitive to the oil pump, therefore JIMS® voids all warranty if the pump is plated.

### POLISHED & BLACK WRINKLE BILLET OIL PUMP COVER (TOP FEED)

This cover was designed for models not having oil tank under transmission. Designed with late oil pressure relief enabling return of excess oil to feed side of oil pump. Use with all aluminum oil pump bodies. (Note: No provision in the cover for front or rear chain oiling).

No.1699E - Polished, Use on JIMS® billet oil pump bodies and Big Twin 1973-91.

No.1699EB - Black Use on JIMS® billet oil pump bodies and Big Twin 1973-91.

No.1699L - Polished, Use on JIMS® billet oil pump bodies and Big Twin 1992-99.

No.1699LB - Black Use on JIMS® billet oil pump bodies and Big Twin 1992-99.

**NOTE:** Oil Pumps are supplied with late style, 1/4"-20 mounting hardware only.



## OIL PUMP RELIEF VALVE SPRINGS

- No.26207-83 - Use on Big Twin late 1973-99 single cam only (including JIMS® oil pumps).
- No.26262-80 - Use on Big Twin 1981-99 single cam only (including JIMS® oil pumps).



## OIL PUMP PRESSURE VALVE

- No.26400-82 - Replaces H-D® 26400-82B. Use on Big Twin late 1982-99 (including JIMS® oil pumps).  
Use on Twin Cam®, cam support plates 1999-present.



## OIL PUMP GEARS

These gears are made from Solid Billet Steel. Use on Big Twin 1968-99 single cam only (including JIMS® Flow Pro) oil pumps and aftermarket pumps. Just by installing JIMS® gear you'll have you an increase over 5% of pressure, as well as an increase of over 5% in volume.

- No.26315-68A - Return drive gear.  
No.26317-68A - Return idler gear.  
No.26326-62A - Feed idler gear.  
No.26328-74 - Feed drive gear.



## OIL PUMP DRIVE GEAR

Made with premium aerospace quality Alloy Bar Steel, heat treated for wear resistance and precision cut to exact tolerances, JIMS® replacement gears are the finest gears available for your stock or replacement engine. (Use with matching JIMS® Gear No. 26345-73 or equivalent)

- No.26349-84 - Use on Big Twin 1954-1990.

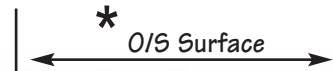

## OIL PUMP DRIVE SHAFT

- No.26346-36 - Use on Big Twin 1936-67.
- \*No.1744 - Use on Big Twin 1936-67, +.005" Oversize O.D.

JIMS® oversize oil pump shafts are designed to eliminate the job of replacing the oil pump drive shaft bushing and ream or hone the worn bushing to size.

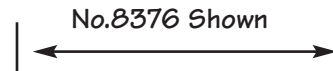

## OIL PUMP DRIVE SHAFT

- No.26346-69/70 - Use on Big Twin 1968-99 single cam only.
- \*No.1719 - Use on Big Twin 1968-present single cam only, +.005" Oversize O.D.



## OIL PUMP SHAFT KIT

- No.2435 - Use on Big Twin 1936-67.  
Kit includes the following:
- 1 - 26346-36 Oil Pump Shaft.
  - 1 - 2486 (H-D® 26340-36) Key.
  - 2 - 2483 (H-D® 26348-15) Keys.
  - 2 - 2487 (H-D® 26348-36) Retaining Rings.



## OIL PUMP SHAFT KIT

- No.2436 - Use on Big Twin 1968-1999 single cam only.  
Kit includes the following:
- 1 - 26346-69/70 Oil Pump Shaft
  - 3 - 2483 (H-D® 26348-15) Keys
  - 1 - 2487 (H-D® 26348-36) Retaining Ring
  - 1 - 2485 (H-D® 11002) Retaining Ring



## OIL PUMP DRIVE GEAR

Billet Steel replacement drive gear made to fit stock and replacement shafts. Precision machined and heat treated to far outlast stock parts. (Use with matching JIMS® gear No.26349-84 or equivalent)

- No.26345-73 - Use on Big Twin 1954-present single cam only, 24 tooth.



# BREATHER VALVE GEARS



## **BREATHER VALVE GEAR (STD SIZE)**

Made from the finest aerospace quality steel and CNC machined to JIMS® highest standards, for precise control of exhausting crank case pressure. Designed to replace the stock plastic breather valve gear. Also available in  $+.030''$  oversize, to correct a damaged breather valve hole.

No. **2338S** - Use on Big Twin 1948-Early 1977.

No. **2337S** - Use on Big Twin Late 1977-99 single cam only.



## **BREATHER VALVE GEAR $+.030''$**

Made in the USA from aerospace grade steel, this is another quality JIMS® product. Oversize by  $+.030''$ , this breather is used to repair a damaged breather hole. Use JIMS® Breather Hole Reamer Tool. A damaged breather hole used to be a costly problem, now it is not. Disassembly of the engine, welding and machining are the usual procedure to repair. Use JIMS® No.1706 tool. No special tools required, just hand tools.

No. **2338** - Use on Big Twin 1948-Early 1977.

No. **2337** - Use on Big Twin Late 1977-1999 single cam only.



## **BREATHER VALVE GEAR WITH ELONGATED OIL HOLE**

This breather gear has an elongated rear hole to aid in better crankcase flywheel cavity vacuum. Made from the finest aerospace quality steel and CNC machined to JIMS® highest standards. Designed to replace the stock plastic breather valve gear. Standard size only.

No. **2337ST** - Use on Late 1977-99 Big Twin single cam only.



## **STEEL BREATHER GEAR ENDPLAY SHIMS**

These shims are manufactured out of stress proof steel. Designed to fit steel breather gears only. These shims are available in 9 different sizes.

(Sold in packs of 5)

### **USE ON BIG TWIN LATE 1979-82, AND MOST ALL STEEL AFTERMARKET GEARS.**

No. **2505** -  $.110''$  (No.25320-79).

No. **2510** -  $.135''$  (No.25326-79).

No. **2506** -  $.115''$  (No.25321-79).

No. **2511** -  $.140''$  (No.25327-79).

No. **2507** -  $.120''$  (No.25322-79).

No. **2512** -  $.145''$  (No.25328-79).

No. **2508** -  $.125''$  (No.25323-79).

No. **2513** -  $.150''$  (No.25328-93).

No. **2509** -  $.130''$  (No.25325-79).

# STARTERS

## JIMS® 1.5KW PERFORMANCE STARTER



JIMS has just released a new 1.5w starter for 07 to present Big Twins. This new style starter can be removed without the need of taking the outer primary off to disconnect the jackshaft bolt. Our new 1.5kw starter has an enclosed housing that supports the starter shaft and starter gear that is attached to the shaft like a Sportster. Available in polished chrome or Black Wrinkle.

 No. 652 - Use on 2007 to present Touring Models, Dyna's, or Softails. (Polished/Chrome finish)

 No. 653 - Use on 2007 to present Touring Models, Dyna's, or Softails. (Black wrinkle finish)



## JIMS® 1.8KW HIGH TORQUE STARTER

These starters incorporate superior windings, high tolerance heavy duty clutch, and a thicker commutator that resists flying shorts. Static balanced for smoother operation, it has the torque to start today's high performance, big inch engines with the least amount of amperage drain. The lower profile design will clear the electronic speedometer for easy installation. These starters are available in Polish/Chrome and Black Wrinkle finish.

**NOTE:** Requires use of spacer block JIMS No.8088 when used on 1990-2006 FLT models. On Softails, Dynas and FXR models you must relocate oil lines and some wiring. See page 103.

No.635 - (Polished/Chrome finish)

Use on Big Twin Models 1989-93.

No.636 - (Black finish)

Use on Big Twin Models 1989-93.

No.637 - (Polished/Chrome finish)

Use on Big Twin - EVO's 1994-99, Twin Cam® Dyna® 1999-05, Twin Cam® FXST 2000-06, Twin Cam® FL 1999-06.

No.638 - (Black finish)

Use on Big Twin - EVO's 1994-99, Twin Cam® Dyna® 1999-05, Twin Cam® FXST 2000-06, Twin Cam® FL 1999-06.

# STARTER RING GEARS & CABLES

## HIGH TORQUE STARTER RING & PINION GEAR SET



Starting issues more often revolve around a stock starter ring and pinion gear, and are often mistaken for a weak starter motor, when actually the solution is a high torque starter ring and pinion gear. Today's modified Big Twin engines with exotic ignition timing and high compression will occasionally cough or backfire during startup. This can lead to broken or chipped teeth on the OEM 102 tooth starter ring gear (94 and later.) Here is the answer that you've been looking for! JIMS® heavy duty high-torque starter ring and pinion gear kit consists of both 66 tooth ring gear, pinion gear, and ring gear mounting hardware.

No.639 - Use on 1994-97 Big Twin Models.

No.640 - Use on EVO, Big Twin 1998-99. Use on Twin Cam® FXST 2000-06. Use on Twin Cam® FXD 1999-05. Use on Twin Cam® FL 1999-06.



## JIMS® STARTER RING GEAR RIVET FIXTURE TOOL

No.965 - Use on 1990-2006 FL, FXST, & 1990-2005 FXR, & FXD

**NOTE:** Use to remove rivets from old starter ring gear on clutch basket. See page 191. For more details see No. 965-IS instructions.

## JIMS® SUPER FLEX PERFORMANCE BATTERY CABLE SETS



JIMS® 1,666 strand Super Flexible Battery Cables exceed all OEM standards. They deliver maximum power from the battery to the starter. Top quality materials assure superior durability, strength and heat resistance.

The unique terminal design and construction provides positive connections for trouble free installation and dependable service. JIMS® Mega-Lugs have at least twice as much copper weight

as standard lugs, and are manufactured with 99% pure electrolytic copper, and then we finish it with 24K gold plating for greater conductivity. These are the heaviest starter ground lugs in the industry and will deliver more cranking power with less voltage drop than any other battery cable. Cable lengths listed in parenthesis for set.

PART NO.	DESCRIPTION
No.641	Use on 1989-06 Softail Models (10" & 12").
No.642	Use on 1984-88 Softail Models (8", 15" & 17").
No.643	Use on 1993-06 FL Models (13", 14" & 8").
No.644	Use on 1989-92 FL Models (33" & 33").
No.645	Use on 1980-88 FL Models (9", 30" & 30").
No.646	Use on 1965-79 FL Models (9", 16" & 16").

PART NO.	DESCRIPTION
No.647	Use on 1991-06 Dyna™ Models (10", 15" & 8").
No.648	Use on 1989-94 Low Rider FXR Models (12" & 16").
No.649	Use on 1982-88 Low Rider FXR Models (12", 16" & 16").
No.650	Use on 2004-06 Sportster® XL Models (12" & 13").
No.651	Use on 1981-03 Sportster® XL Models (11" & 16").



# JIMS PERFORMANCE CLUTCHES



**No.8376 SHOWN**

## **JIMS® HIGH PERFORMANCE BILLET CLUTCH**

JIMS® sets the standard for performance V-Twin Clutches! Whether your bike is stock or modified - street or strip - the JIMS® clutch has what it takes to get the job done. These billet clutches feature a 100% increase in clutch surface area compared to stock. Each clutch includes a CNC machined billet aluminum pressure plate, friction plates, steel plates, a steel inner hub, and additional sets of coil springs (40, 58, or 82LB) to allow you to tune your clutch to your needs. The JIMS® High Performance clutch can also be run wet or dry in an open or enclosed primary. *For more details see No. 8375-IS instructions.*

No.8375 - Use on 1990-97 Big Twin models.

No.8376 - Use on 1998-99 EVO's Big Twins.

Use on 1999-06 FL's.

Use on 1999-05 FXD's.

Use on 2000-06 FXST.

No.8379 - Use on 2007 - 2010 FXST, FL and 2006 - present FXD.

**NEW** No.8382 - Use on all 2011 to present Big Twins.

17



**Terry Stewart**



**Mark Colburn**



**No.8381 SHOWN**

## **JIMS® PERFORMANCE CLUTCH SETS**

JIMS® replacement clutch plate sets were developed for the Big Inch, performance motors. These clutch sets consists of friction and steel drive plates.

- No.8381 - Use on JIMS® Clutch Kit No. 8375 for 90-97 Big Twin models.
- No.8380 - Use on JIMS® Clutch Kit No. 8376, 8379, and 8382 for 1998 to present Big Twins.



## **CLUTCH ASSEMBLY SERVICE TOOL FOR BIG TWINS**

This tool will safely disassemble and assemble the clutch shell assembly. Easily removes and installs the clutch hub from it's bearing. Safely removes and installs the clutch shell ball bearing (H-D® No.37906-90) without any damage to the new bearing. This is done by pushing on the outer perimeter of bearing. For more details see No. 971-IS instructions.

No.971 - Use on all Big Twins 1990-2006.



**Mike, Garry, & Jim at Old Faithful**



## RIGHT SIDE DRIVE COMPLETE TRANSMISSIONS EVO & TWIN CAM®

Right Side Drive done the right way! JIMS® Right Side Drive (RSD) 6-Speed Transmissions have the most innovative design, strength, quality and durability in the industry. Twin Cam® transmissions ship with chrome H-D® top covers. It looks as good as it works too. All other covers are CNC machined from billet aluminum. They are then polished and chrome plated to JIMS® high standards. Accepts either hydraulic or cable clutch actuation, and is a drop-in for most major manufacturers right side drive frames. No frame modifications are required.

Built with large powerful engines in mind, JIMS® Right Side Drive transmission have unique features important to its strength and durability. It has an outboard support bearing for the output mainshaft. This bearing minimizes flexing of the shaft and enhances reliability with engines like the JIMS® 120. The outboard bearing support, are pressure fed by a built-in oil pump. The transmission shafts are positively located. There is no stronger right side transmission available.

Every part of the JIMS® RSD is manufactured in America from the finest materials. Every part is machined to JIMS® close tolerances. Because of JIMS® manufacturing efficiency, the JIMS® Right Side Drive transmission is also a smart economical choice.....The best for Less!

For more details see No. 8236-IS instructions.

### RIGHT SIDE DRIVE "EVO" COMPLETE TRANSMISSIONS

Right Side Drive EVO Softail® transmissions have been installed into Softail® cases specific to the "transmission mount". ANY installation of an RSD transmission is considered a CUSTOM application, thus modifications may be necessary. RSD transmissions are NOT compatible with a stock chassis.

Gear . . . .Ratio
1 . . . . .2.94
2 . . . . .2.21
3 . . . . .1.57
4 . . . . .1.23
5 . . . . .1.00
6 . . . . .0.86:1 (Overdrive)

PART NO.	APPLICATION/ YEAR	1ST GEAR RATIO	CASE	PULLEY COVER	JIMS® TRAP DOOR
8248	Softail® 90-99	Close Ratio	Black	Mechanical	Chrome 7075T
8249	Softail® 90-99	Close Ratio	Silver	Mechanical	Chrome 7075T
8250	Softail® 90-99	Close Ratio	Polished	Mechanical	Chrome 7075T
8251	Softail® 90-99	Close Ratio	Black	Hydraulic	Chrome 7075T
8252	Softail® 90-99	Close Ratio	Silver	Hydraulic	Chrome 7075T
8253	Softail® 90-99	Close Ratio	Polished	Hydraulic	Chrome 7075T



**EARLY SOFTAIL PICTURED**

### RIGHT SIDE DRIVE TWIN CAM® COMPLETE TRANSMISSIONS

Right Side Drive Twin Cam® transmissions are installed into transmission cases specific to the Twin Cam® "transmission mount". ANY installation of an RSD transmission is considered a CUSTOM application making modifications be necessary. RSD transmissions are NOT compatible with stock chassis.

PART NO.	APPLICATION/ YEAR	1ST GEAR RATIO	CASE	PULLEY COVER	JIMS® TRAP DOOR
8259	Softail® 00-06	Close Ratio	Black	Mechanical	Chrome 7075T
8260	Softail® 00-06	Close Ratio	Silver	Mechanical	Chrome 7075T
8266	Softail® 00-06	Close Ratio	Black	Hydraulic	Chrome 7075T
8267	Softail® 00-06	Close Ratio	Silver	Hydraulic	Chrome 7075T



**LATE SOFTAIL PICTURED**



# RIGHT SIDE DRIVE TRANSMISSION

## RIGHT SIDE DRIVE, 6-SPEED OVERDRIVE, SUPERKITS TWIN CAM® & EVO SOFTTAILS

Built with large powerful engines in mind, JIMS® Right Side Drive transmission has unique features that are important to its strength and durability. It has an outboard support bearing for the output mainshaft. This bearing minimizes flexing of the mainshaft and enhances reliability with engines like the JIMS® 120", 131" & 135". The bearing, including the outboard support bearing, are pressure fed by a built-in oil pump. There is no stronger RSD transmission available.

JIMS® RSD 6 Speed Super kits are designed to install in any H-D® Softail® transmission case or aftermarket Softail® cases. Some minor modifications may be required to trans case depending on the manufacturer. Complete instructions for installation are provided with each kit. RSD super kits are supplied with a chrome aluminum trap door.

You'll have a choice of a hydraulic actuated clutch pushrod system or a mechanical actuated pushrod. It is best if these assembled RSD transmissions are installed in a RSD style frame offered by most frame manufacturers for ease of installation and fitment. *For more details see No. 8236-IS instructions.* RSD transmissions will not bolt into a stock style frame without extensive modification to the frame.

**NOTE:** Different parts options are listed below, depending on the year and type of trans case being used, either an EVO or Twin Cam®.

### RSD SUPER KIT FITS:

- No.8235 - 1990 - 2006 Softail® transmission cases, supplied with hydraulic actuated clutch pushrod system. This hydraulic system will require a master cylinder, hydraulic line and Dot 5 or equivalent (example of master cylinder kit H-D® No.45232-03A.)
- No.8236 - 1990 - 2006 Softail® transmission cases, supplied with mechanical actuated clutch pushrod system has a ball and ramp system that works with common O.E.M. type clutch cables.

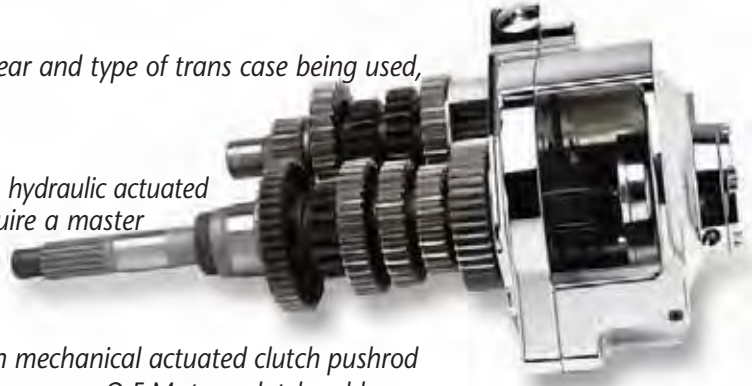

### OPTIONAL PRODUCT FOR INSTALLING A RSD IN A 1990-1999 EVO TRANSMISSION CASE:

The following list of product will be required for installation, if not previously obtained or on the transmission case.

- No.7514 - Trans-case shifter shaft sleeve (replace existing sleeve or modify the longer early existing sleeve).
- No.1664 - Trans-case shifter shaft sleeve remover / installer tool, use to install JIMS® No.7514 shifter shaft sleeve.
- No.33904-00 - Neutral switch with o-ring (this late switch must be installed when using a neutral light).
- No.8135 - Neutral switch wiring kit: (use on 1990-1997) use of this wiring kit will convert a single pole wiring harness into a two pole wiring harness, instructions included.
- No.8136 - Neutral switch spacer kit: Required when using a OEM top cover (lid) from 1990 to 1997 and switch No.33904-00.



No.8247  
MECHANICAL VERSION

### OPTIONAL PRODUCTS FOR INSTALLING A RSD IN A 2000-2006 TWIN CAM® TRANSMISSION CASE:

The following list of product will be required for installation, if not previously obtained or on the transmission case.

- No.33904-00 - Neutral switch with o-ring (this late switch must be installed when using a neutral light).
- No.8135 - Neutral switch wiring kit: use of this wiring kit will convert a single pole wiring harness into a two pole wiring harness or for custom wiring application, instructions included.



No.8246  
HYDRAULIC VERSION

## FAT 5™ SUPERKIT OVERDRIVE TRANSMISSIONS EVO & TWIN CAM®

You want strong? We have strong! JIMS® "Fat 5™ Overdrive" is simply the strongest, toughest gearbox made. Period. JIMS® took advantage of its, more compact shifter technology to increase the width and strength of every gear. The width increase varies from 18% to 53%, depending upon the loads each gear set must carry.

Big Power is more popular than ever. Large engines like the JIMS® 120", 131" & 135" deliver double the stock power and torque. When such power is linked to the ground through high torque clutches and big sticky tires, the peak loads on transmission gears rise far above what anyone but JIMS® ever expected their trannies to have to endure.

An oil filler spout spacer, JIMS No.8088 may be required on 1993 to 2006 FL's. See page 103.

For more details see No. 8273-IS instructions. One final note – "Buy American!"



Gear . . .	Ratio
1 . . . . .	2.91
2 . . . . .	1.93
3 . . . . .	1.31
4 . . . . .	1.00
5 . . . . .	0.886
<i>(Overdrive)</i>	





## FAT 5-SPEED OVERDRIVE COMPLETE TRANSMISSIONS & OVERDRIVE SUPERKITS

Got strong? We have strong! JIMS® "Fat 5 Overdrive" is simply the strongest, toughest gearbox made. Period. JIMS® took advantage of its new, more compact shifter technology to increase the width and strength of every gear. The width increase varies from 18% to 53%, depending upon the loads each gear set must carry.

Big power is more popular than ever. Large engines like the JIMS® 135" deliver double the stock power and torque. When such power is linked to the ground through high torque clutches and big sticky tires, the peak loads on transmission gears rise far above what anyone but JIMS® ever expected their trannies would need to endure.

All are available with a mechanical clutch activated system only. The Fat 5 Overdrive fits both Evo and Twin Cam® chassis. However, it is wider on the right side which may interfere with other components. For this reason, we consider our Fat 5 Overdrive to be part of a custom build and not a drop-in product. It is available as a JIMS® Super Kit or complete transmission. As you'd expect, all Fat 5 gears are manufactured to JIMS® renowned standards of strength and quality. *For more details see No. 8273-IS instructions.*

### FAT 5 OVERDRIVE COMPLETE TRANSMISSIONS

Fat Gear™ complete transmissions are shipped as a complete assembly installed in a case. Transmissions DO NOT include pulley. Fat Gear™ Transmissions are a CUSTOM application. Modifications to the exhaust bracket and oil filler spout may be necessary.

PART NO.	APPLICATION/ YEAR	1ST GEAR RATIO	CASE	JIMS® TRAP DOOR
8279	00-06 FXST	2.91	Silver	Chrome
8280	00-06 FXST	2.91	Black	Chrome
8282	90-99 FXST	2.91	Silver	Chrome
8283	90-99 FXST	2.91	Black	Chrome
8284	90-99 FXST	2.91	Polished	Chrome

### FAT 5 OVERDRIVE SUPERKITS

Fat Gear™ Superkits are shipped as a gear cluster installed into a trap door. All necessary shifting components, gaskets and unique components are supplied to be installed into an existing transmission case. Fat Gear™ Transmissions are a CUSTOM application. Modifications to the exhaust bracket and 1993 to 2006 FL's oil filler spout may be necessary. Also trans top lid will require shift lever clearance modification on certain models.

**\* AN OIL FILLER SPOUT SPACER, JIMS NO.8088 MAY BE REQUIRED ON 1993 TO 2006 FL'S.**

PART NO.	APPLICATION/ YEAR	1ST GEAR RATIO	JIMS® TRAP DOOR
8273	91-00 FXD	2.91	Chrome
8273	90-99 FXST & FXR	2.91	Chrome
* 8273	90-00 FLH	2.91	Chrome
8274	00-06 FXST	2.91	Chrome
* 8274	01-06 FLH	2.91	Chrome
8275	01-05 FXD	2.91	Chrome



**6 YEARS /  
60K MILES  
WARRANTY**

**VERY IMPORTANT:** The Fat Gear transmissions incorporate a unique trapdoor and a mechanical cable type side cover design that extends approximately .560" from a stock side cover. For this reason, certain modifications may be necessary to the exhaust bracket and or FL's oil filler spout to properly install a Fat Gear transmission. For this reason, this is a custom application only.





## 5 SPEED TRANSMISSIONS & 6-SPEED OVERDRIVE TWIN CAM® & EVO TRANSMISSIONS



**6 YEARS /  
60K MILES  
WARRANTY ON  
COMPLETES**



**\*SPECIAL APPLICATION NOTE:** JIMS® Softail® and FXR single cam transmissions can be used in any year, single cam only, when used with the late starter motor, inner and outer primaries, clutch, etc...



### 5-SPEED PRECISION-CUT GEARS

JIMS® Precision-Cut 5-Speed transmissions feature late style 5-speed shifter upgrade, chromed covers, trap door, and are shipped complete with bottled transmission oil and instruction sheet No.8000-IS.

PART NO.	APPLICATION/ YEAR	1ST GEAR RATIO	CASE	CASE FINISH	JIMS® TRAP DOOR
8000	Softail® 1990-99*	Close Ratio	JIMS®	Plain Aluminum	Chrome 7075T
8002	Softail® 1990-99*	Stock Ratio	JIMS®	Black Wrinkle	Chrome 7075T
8004	Softail® 1990-99*	Close Ratio	JIMS®	Polished Aluminum	Chrome 7075T
8001	FXR 1990-94 & 1999	Close Ratio		Plain Aluminum	Chrome 7075T
8003	FXR 1990-94 & 1999	Stock Ratio		Polished Aluminum	Chrome 7075T

### 6-SPEED OVERDRIVE PRECISION-CUT GEARS

JIMS® Precision-Cut 6-Speed transmissions with late model improved shift drum and shift lever assemblies. Includes chromed covers, trap door and are shipped complete with bottled transmission oil and instruction sheet No.8085-IS.

PART NO.	APPLICATION/ YEAR	1ST GEAR RATIO	CASE	CASE FINISH	JIMS® TRAP DOOR
8000C6	Softail® 1990-99*	Close Ratio	JIMS®	Plain Aluminum	Chrome 7075T
8002C6	Softail® 1990-99*	Close Ratio	JIMS®	Black Wrinkle	Chrome 7075T
8004C6	Softail® 1990-99	Close Ratio	JIMS®	Polished Aluminum	Chrome 7075T
8001C6	FXR 1990-94 & 1999	Close Ratio		Plain Aluminum	Chrome 7075T
8003C6	FXR 1990-94 & 1999	Close Ratio		Polished Aluminum	Chrome 7075T
8111	Softail® 2000-2006	Close Ratio	H-D®	Plain Aluminum	Chrome 7075T
8112	Softail® 2000-2006	Close Ratio	H-D®	Black Wrinkle	Chrome 7075T

## TRANSMISSION TECH INFORMATION

### PRECISION CUT FORGED GEARS

Gears are made complete on CNC machine centers, and made from materials that exceed 8620 steel. All shifting dogs are CNC machine cut with lead in ramps for better and quicker shifting. All gears are checked dimensionally and for surface finish for quiet smooth shifting.

### CLOSE RATIO VS. STOCK RATIO

Stock ratio transmission gears for 5-speed Big Twins were developed by Harley-Davidson® engineers for all of their models. An overall internal gear ratio was chosen to work well with everything from a Dresser to a Dyna™ Super Glide.

This stock ratio (3.21:1 ratio low gear) works fine with the approximately 69 horsepower that the stock Harley Davidson® motor makes.



**CLOSE RATIO 1ST**



**JIMS No.2385-7  
5-SPEED SUPER KIT**

### JIMS® 6-SPEED OVERDRIVE TRANSMISSION GEARS

JIMS® is proud to offer 6-speed overdrive transmission gears made in the U.S.A. by JIMS®. Imagine riding down the road at 75 MPH in 5th gear and by shifting into 6th you reduce your engine RPM by almost 500 RPM.'s. It's possible to have this option with the strength and reliability of JIMS® quality gears and shafts. All gears are standard width for performance and strength, with first gear being close ratio 2.94, and the last four being the same ratio as a stock 5-speed. 6th gear goes to .86:1 overdrive.

Gear . . . .Ratio
1 . . . . .2.94
2 . . . . .2.21
3 . . . . .1.57
4 . . . . .1.23
5 . . . . .1.00
6 . . . . .0.86:1 (Overdrive)

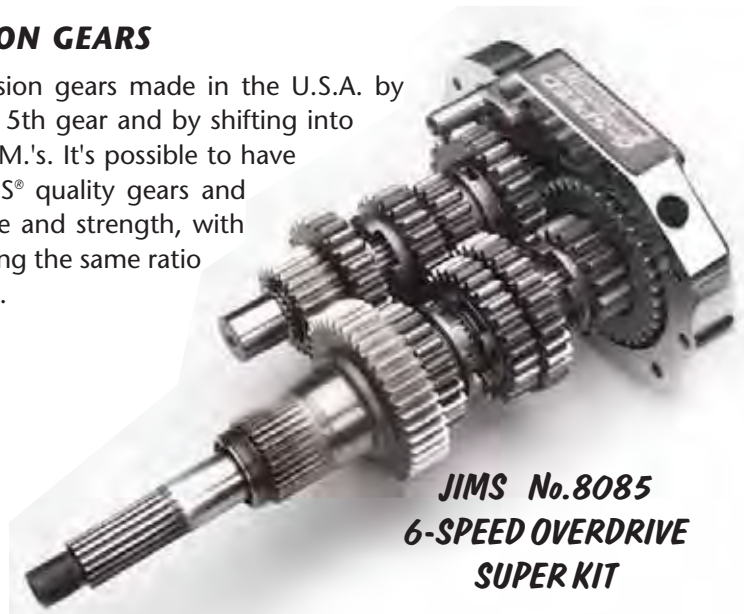

**JIMS No.8085  
6-SPEED OVERDRIVE  
SUPER KIT**



### JIMS® FL OIL FILLER SPOUT SPACER

This is a universal spacer designed to give you clearance for the OEM oil fill spout covers on the FL model 5-speed transmissions or aftermarket 6-speeds. This spacer is a must for the longer High Performance starters motors. Also used for trapdoor clearance or spout cover vent line/speedo sensor clearance on aftermarket 6-speeds. You will need to do some fabrication work on the spacer and possibly the spout cover depending on what clearance you are dealing with and year of FL. This polished aluminum spacer is 1-7/8" thick.

No.8088 - Use on 1993 - 2006 Big Twin FL 5-speed transmissions or aftermarket 6-speeds.

## 6-SPEED OVERDRIVE FOR A 4-SPEED FRAME & 5-SPEED FOR A 4-SPEED FRAME



6  
/  
4

JIMS® 4/5 and 4/6 conversion transmissions are designed to fit most 1970 – early 1984 Harley-Davidson Shovelhead electric start models only. However, we do not consider our 4/5 and 4/6 transmissions to be a "drop-in" product. We offer them as custom transmissions, requiring installation by an experienced Harley mechanic.

Gear . . . . .	Ratio
1 . . . . .	2.94
2 . . . . .	2.21
3 . . . . .	1.57
4 . . . . .	1.23
5 . . . . .	1.00
6 . . . . .	0.86:1 (Overdrive)

These transmissions are shipped fully loaded with the finest components available by JIMS®, such as: forged gears with lead-in ramping and back-cut engagement dogs, close ratio 1st gear, precision machined and heat-treated counter and main shafts, chrome billet trap doors, chrome billet top and side covers, and JIMS® performance gaskets. For more details see No. 8028C6-IS instructions.

### 6-SPEED FOR A 4-SPEED FRAME

PRECISION-CUT 4/6 SPEED

PART NO.	APPLICATION/ YEAR	CASE
8028C6	FX & FL 1970 early '84	Plain Aluminum
8030C6	FX & FL 1970 early '84	Polished Aluminum

#### BUILDERS NOTE:

If installed on any other motorcycle other than one that came stock with a dry clutch, it will be the responsibility of the builder to install the proper parts needed to make this transmission installation work and function safely. For example: Primaries and other related parts. There is not a standard list of parts and or modifications required to install these transmissions.

#### Additional Parts Required:

- Clutch pushrods: No.37090-79 (left), No.37088-79 (center) and No.37089-79 (right)
- Clutch release bearing kit:  
JIMS® No.2226 or H-D® No.37312-75 (1) + No.37313-80 (2), + No.11096 (1)
- 1986 and later clutch cable & pivot pin
- 22T or larger offset sprocket for early 5-speed (1980 – 83) or special pulley
- Main drive gear nut (No.35211-36)
- Inner primary seal (No.12018)
- Inner primary bearing (No.9037)
- Shift lever:  
JIMS® No.33715-85AC or H-D® No.33715-85
- Shovelhead style "dry" clutch hub as used on 4-speed (tapered shaft with woodruff key)
- 1986 or later clutch cable
- Forward or aftermarket mid-controls
- Offset rear sprocket or special pulley
- Chain or belt electric start primary drive

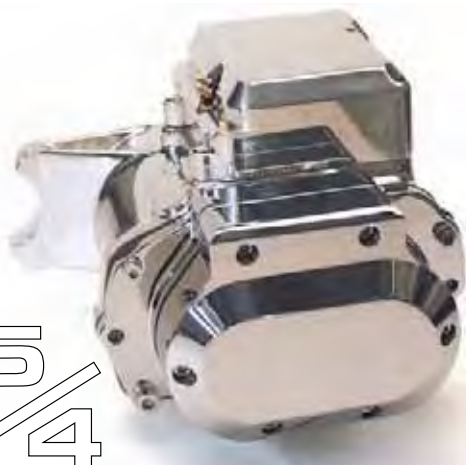

5  
/  
4

Gear . . . . .	Ratio
1 . . . . .	2.94
2 . . . . .	2.21
3 . . . . .	1.57
4 . . . . .	1.23
5 . . . . .	1:1

#### Optional Parts: (See Build Note)

- If you wish to use a belt final drive, a special front pulley is required.
- Electronic speedometer sensor

#### Possible fitment issues:

- Some installations may require modification or fabrication of exhaust, oil tank or electric starter mounting brackets.
- 22-tooth chain sprockets require modification of the transmission casting to clear the chain.
- Some inner primary covers require modification to clear the main drive nut.
- Some electric starter installations require modification of the transmission case for clearance.

### 5-SPEED FOR A 4-SPEED FRAME

PRECISION-CUT 4/5 SPEED

PART NO.	APPLICATION/ YEAR	CASE
8028	FX & FL 1970 early '84	Plain Aluminum
8030	FX & FL 1970 early '84	Polished Aluminum

For more details see No. 8028-IS instructions.



## JIMS® 6-SPEED OVERDRIVE SUPER KITS

Reduce vibration that creates wear and enjoy a relaxing cruise with JIMS® Overdrive 6-speed transmission. Our Overdrive 6th gear (.86:1 ratio) lowers engine rpm by almost 475 at 75 mph. In addition, 1st gear is a 2.94:1 close ratio that widens your bike's speed range in 1st gear and lessens the rpm drop when shifting into second. You can enjoy having a gear for every situation, from putting in traffic to open road cruising. Combined with the convenience of well-spaced gearing is the renowned strength and reliability of JIMS® race-proven, American made gears and shafts.

### GENERAL NOTES:

- All JIMS® Super Kits require a No.8042K Speedo Sensor Block-Off Plate Kit. If the speedometer is not driven from the transmission, then two block off plates kits are required.
- All JIMS® 6-speed installations require the speedometer be recalibrated. For calibration kits see this page.
- The JIMS® Trap Door extends 3/8" farther to the right than the stock part. Alterations to some parts that attach to or around the trap door may be required.
- JIMS® Spout Spacer No.8088 on page 103 will be required on FL's and spout may need modification.

### 6-SPEED OVERDRIVE TRANSMISSION SUPER KITS

Just like our popular 5-speed transmission super kits, our 6-speed kits are made with the same aerospace quality steel and precision machining. These kits are carefully assembled and ready to slip into your transmission case without removing it from your motorcycle. Detailed instructions and a JIMS® gasket set included. Use as a complete gear set. *For more details see No. 8085-IS instructions.*

All kits incorporate JIMS® PRECISION CUT™ gears.



Gear . . .	Ratio
1 . . . . .	2.94
2 . . . . .	2.21
3 . . . . .	1.57
4 . . . . .	1.23
5 . . . . .	1.00
6 . . . . .	0.86:1 (Overdrive)

KIT NO	APPLICATION
* 8085L	2000-2006 Twin Cam® FXST (Softail®) and 2001-06 FLHT, and 2001-05 FXD
8085	Big Twins 1990-1999 and 1999-2000 FLHT, FXD

\* **IF INSTALLING IN 2002 TO 2006 FL TRANS CASE, YOU WILL NEED A JIMS No. 8088 OIL FILLER SPOUT SPACER FOR CLEARANCING TRANS TO MOTOR VENT LINE.**



### JIMS® 6-SPEED OVERDRIVE SUPER KIT & PARTS

FOR 4-SPEED FRAME STYLE CONVERSION CASE

Gear . . .	Ratio
1 . . . . .	2.94
2 . . . . .	2.21
3 . . . . .	1.57
4 . . . . .	1.23
5 . . . . .	1.00
6 . . . . .	0.86:1 (Overdrive)

4-5-6 Super Kit: 6-speed parts to fit in JIMS® 4-5 trans case. This Super Kit uses the same proven 6-speed transmission parts as found in JIMS® other 6-speed Super Kits and JIMS® 6-speed complete transmissions. Comes complete with forged Precision-Cut gears, close ratio 1st gear, shafts, JIMS® chrome trap door, shift drum, bronze shift forks, gaskets and bearings and ready to install in one of the cases No.8096 or No.8096P. *For more details see No. 8028C6-IS instructions.*

No.8101 - Precision-Cut gears. Use on all 1970 - early 1984 FX electric start only, and FL style frames with JIMS® new 4-5 trans case or aftermarket equivalent.

# 5 & 6-SPEED TRANSMISSION SUPER KITS



Gear . . . .	Ratio
1 . . . . .	2.94
2 . . . . .	2.21
3 . . . . .	1.57
4 . . . . .	1.23
5 . . . . .	1.00
6 . . . . .	0.86:1 (Overdrive)

## JIMS® 6-SPEED OVERDRIVE SUPER KIT & PARTS

FOR 4-SPEED FRAME STYLE CONVERSION CASE

4-5-6 Super Kit: 6-speed parts to fit in JIMS® 4-5 trans case. This Super Kit uses the same proven 6-speed transmission parts as found in JIMS® other 6-speed Super Kits and JIMS® 6-speed complete transmissions. Comes complete with forged Precision-Cut gears, close ratio 1st gear, shafts, JIMS® chrome trap door, shift drum, bronze shift forks, gaskets and bearings and ready to install in one of the cases No.8096 or No.8096P. For more details see No. 8028C6-IS instructions.

No.8101 - Precision-Cut gears. Use on all 1970 - early 1984 FX electric start only, and FL style frames with JIMS® new 4-5 trans case or aftermarket equivalent.

## 5-SPEED TRANSMISSION SUPER KITS

We use JIMS® proven transmission parts to start with, then top it off with a JIMS® Gasket set, together in one convenient package. This super kit is ready to slip into your favorite transmission case, H-D® or aftermarket. All super kits are built in house with the finest air gauging instruments available, with inspections before and after assembly. All kits incorporate JIMS® PRECISION CUT™ gears (Use as a Complete Gear Set). For more details see No. 2386-IS instructions.



Kit No.	Application	FEATURES
2386-7	Big Twin 1990-06 Single & Twin Cam®	Close Ratio First Gear - 7075-T651 Billet Polished Aluminum Trap Door
2386	Big Twin 1990-06 Single & Twin Cam®	Stock Gear Ratio - 7075-T651 Billet Polished Aluminum Trap Door
2385-7	Big Twin 1985-89	Close Ratio First Gear - 7075-T651 Billet Polished Aluminum Trap Door



Gear . . . .	Ratio
1 . . . . .	2.94
2 . . . . .	2.21
3 . . . . .	1.57
4 . . . . .	1.23
5 . . . . .	1:1

## JIMS® 5-SPEED SUPER KIT AND PARTS

FOR 4-SPEED FRAME STYLE CONVERSION CASE

4-5 Super Kit: 5-speed parts to fit in JIMS® 4-5 trans case. This Super Kit uses the same proven transmission parts as found in JIMS® other Super Kits and JIMS® complete transmissions. Comes complete with: JIMS® forged Precision-Cut gears, close ratio 1st gear, shafts, JIMS® chrome trap door, shift drum, bronze shift forks, gaskets and bearings and ready to install in one of the cases No.8096 or No.8096P. For more details see No. 8100-IS instructions.

No.8100 - Precision-Cut gears. Use on all 1970 - early 1984 electric start only, FL style frames with JIMS® new 4-5 trans case.

# TRANSMISSION REBUILD SERVICE RSD & FAT 5 REBUILD KITS



## JIMS NOW OFFERS A TRANSMISSION REBUILD SERVICE FOR HARLEY DAVIDSON® AND AFTERMARKET TRANSMISSIONS.

**THIS INCLUDES YOUR OLD 5-SPEED ALL THE WAY THROUGH THE NEW CRUISE DRIVE!**

We all know times are tough. For some, that means keeping your "older" motorcycle running good instead of upgrading to a new bike. That's where this new Transmission Rebuild Service from JIMS comes in. You can now send your old, tired transmission into JIMS for a complete overhaul: JIMS will completely disassemble your transmission, inspect all wear surfaces and replace all bearings, and seals\*. This is a great option for those who are trying to "maintain" their current bike instead of buying a new transmission or a new motorcycle. JIMS has built a reputation for manufacturing and assembling quality transmissions, including 5 and 6 speeds, Right Side Drives with bearing support and the JIMS Fat 5™ overdrive. This expertise is now available as an affordable option by industry professionals.

For more information, please contact JIMS.

\*If new gears or shafts are deemed necessary, additional charges may apply.

PART NO.	DESCRIPTION
8131	All Screamin' Eagle 6 SPD Transmissions.
8132	All H-D Cruise Drive 6 SPD Transmission.
8133	All Aftermarket 6 SPD Transmissions.
8134	All H-D 5 SPD Transmissions.

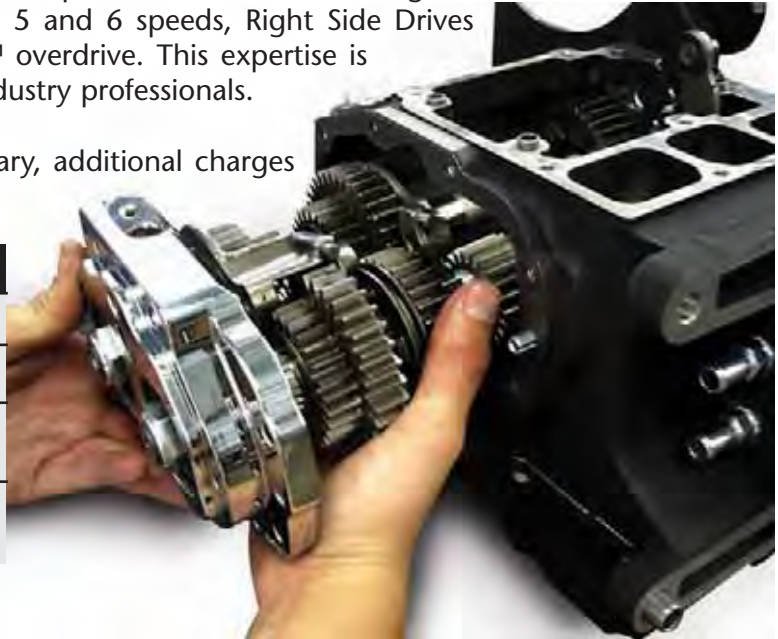

## JIMS RIGHT SIDE DRIVE TRANSMISSION REBUILD KIT

JIMS now offers a rebuild kit for any of JIMS Right Side Drive complete transmissions or JIMS Super Kits using mechanical or hydraulic clutch. This kit includes all retainers, seals, o-rings, bearings, races, and gaskets. For parts list and more detail see No. 8236-IS.



No. 8269 - Use rebuild kit on any JIMS Right Side Drive complete transmissions or Super Kits with mechanical or hydraulic clutch.



No. 890 - JIMS RSD mechanical clutch gasket & seal kit only. For more details see 890-IS.

No. 891 - JIMS RSD hydraulic clutch gasket & seal kit only. For more details see 891-IS.



## JIMS FAT 5 TRANSMISSION REBUILD KIT

JIMS now offers a rebuild kit for any of JIMS Fat 5 complete transmissions or Super Kits. This kit includes all retainers, seals, o-rings, bearings, races, and gaskets. For parts list and more detail see No. 8273-IS.

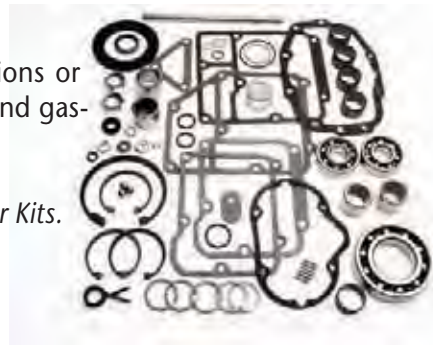

No. 8277 - Use rebuild kit on any JIMS Fat 5 complete transmissions or Super Kits.



No. 892 - JIMS FAT5 gasket & seal kit only. For more details see 892-IS.



# 4,5, & 6 -SPEED TRANSMISSION REBUILD KITS

**NEW**

## JIMS COMPLETE TRANSMISSION REBUILD KITS

If you've ever used any of JIMS rebuild kits in the past, then you know the convenience, and time saved by ordering just one part number that comes with all the necessary gaskets, seals, locks and bearings you will need to completely rebuild a transmission all at one time. One part number, one price and you're done. For more Cruise Drive details see No. 1056-IS instructions or for Screamin Eagle details see No.1060-IS instructions.



**KIT No.1067 SHOWN**

### CRUISE DRIVE (LATE 6 SPEED TRANS)

- No. 1056 - Use on 2007 - present FLH
- No. 1067 - Use on 2006 - present FXD
- No. 1068 - Use on 2007 - present FXST

### SCREAMIN' EAGLE 6 SPEED TRANS

- No. 1060 - Use on 1990 - 2006 FLH
- No. 1061 - Use on 1991 - 2005 FXD
- No. 1062 - Use on 1990 - 2006 FXST

## 5 OR AFTERMARKET 6-SPEED OVERDRIVE TRANSMISSION REBUILD KITS

We use JIMS® proven transmission parts to start with, then top it off with a JIMS® gasket set, together in one convenient package. This is a big time saver. For more details see No.1035-IS instructions.

KIT NO.	APPLICATION
1019	Big Twin 1980-Early 1984 5-Speed
1020	Big Twin Late 1984-1990 5-Speed
1021	Big Twin 1991-1998 5-Speed or aftermarket 6-Speed
1035	Big Twin 1999-2006 5-Speed or aftermarket 6-Speed



## 4-SPEED TRANSMISSION REBUILD KITS

We use JIMS® proven transmission parts to start with, then top it off with a JIMS® Gasket set, together in one convenient package. This is a big time saver. Note: Most kits include standard O.D. size races – please order over-size races separately. For more details see No.1035-IS instructions.

KIT NO.	APPLICATION	ASSEMBLY TIPS
33031-36	Big Twin 1936-Early 1976	Use JIMS® Shift Fork Gauge No.96384-39 to align Shifter forks
33031-76E	Big Twin Late 1976-Early 1977	Use JIMS® Shift Fork Gauge No.96384-39 to align Shifter forks
33031-76L	Big Twin Late 1977-Early 1979	Use JIMS® Shift Fork Gauge No.96384-39 to align Shifter forks
33031-80	Big Twin Late 1979-1986	Use JIMS® Shift Fork Gauge No.96385-78A to align Shifter forks

# TRANSMISSION CASES & NEUTRAL SWITCHES

## JIMS® 5-SPEED OR 6-SPEED TRANSMISSION CONVERSION CASE FOR A 4-SPEED FRAME

JIMS® 4/5 or 4/6 transmission case is cast from 356T6 aerospace quality aluminum material and manufactured on the latest C.N.C. equipment. With this case, you can build a new 5-speed, using kit No.8100, 8100P, and JIMS® 6-speed overdrive transmission No.8101, 8101P for your 4-speed motorcycle. For 4/6-Speeds, some case modification are required. Complete instructions included. *For more details see No. 8028C6-IS instructions.*



**No.8096** - (Plain Finish) Use on all 1970 - early 1984 FL style frames.

**No.8096P** - (Polished Finish) Use on all 1970 - early 1984 FL style frames.



## FXR TRANSMISSION CASE

All cases are made from 356-T6 prime heat treated aluminum. The cases are then CNC machined to exact tolerances, which provide a superior strength and fit. All cases are offered in brilliant show polish or plain finish. Either are perfect for that custom application or for just upgrading your existing ride. These cases are 2 to 3 times stronger than stock and accept all OEM and JIMS® transmission parts and covers. This case has provisions for stock speedo sensor pickup. If a speedo sensor is not used, or you are installing a 6-speed gear set, you must install a speedo block-off plate (JIMS® No.8042K).

**No.2530** - 1990-94, 1999 FXR, Plain finished case. Single Cam only.

**No.8013** - 1990-94, 1999 FXR, Polished case. Single Cam only.

## JIMS® SOFTAIL TRANSMISSION CASE

JIMS® case, along with JIMS® gears, can handle the loads of big inch motors as well as stock engines. JIMS® casting is made of 356T6 aluminum aerospace quality material. Case comes with provisions to install speedo sensor, or if not used order JIMS® No.8042K speedo sensor blockoff plate kit. JIMS® transmission cases are machined to close tolerance and will accept JIMS® gears as well as OEM or other aftermarket gears. *For more details see No. 7999-IS instructions.*



**No.7999B** - Use on Softail®, black finish, replaces H-D® No.34732-96 Single Cam only.

**No.7999** - Use on Softail®, plain, replaces H-D® No.34732-96 Single Cam only.

**No.7999P** - Use on Softail®, polished, replaces H-D® No.34732-96 Single Cam only.

**NOTE:** Can be used for any year 5-speed Softail® application, single cam, if used with a late starter motor, No.31553-90 or equivalent, inner and outer primaries, clutch etc.

## TRANSMISSION NEUTRAL SWITCH

All are quality American made switches and meet or exceed OEM specifications and directly replace H-D® Part Numbers.



Normally closed switch replaces H-D No.33900-59C

**No.621** - Use on 1959-64 FLS, Late 1973 - early 1979 FL and FX, 1982-94 FXR, 1991-97 FXD, 1980-97 FLT, 1986-97 FXST, 1986-98 XL.



Normally closed switch replaces H-D® No.33902-98. Use with H-D® harness 72405-98BK or 72405-98TN.

**No.33902-98** - Use on 1998-00 FXD, FLT, 1998-99 FXST, and 1999 FXR.



This is a normally open switch. Replace H-D® No.33904-00A.

**No.33904-00** - Use on Big Twin 2001-06 FL's, FXST's. Use on Big Twin 2001-05 FXD's.

# BILLET TRAP DOORS



Exhaust Mount Hole



## JIMS® 5-SPEED BILLET TRAP DOORS

All of JIMS® trap doors are designed to be used with the 100 HP+ High Performance engines used in today's Big Twins. They are 5 times stronger than cast stock trap doors, manufactured with premium aluminum and can be ordered in show quality chrome or polished form. The bearing bore holes are held perpendicular to the mounting flange to +.0002". These doors will accept either early or late clutch release covers.

**NOTE:** If using an earlier clutch release cover this will not cover unchromed surface completely when mounted.

### TRAP DOORS WITH EXHAUST MOUNT FOR SMALL BEARING #8998

Small bearing trap doors were originally used on all Big Twins 1980-98. For more details see No. 2347-IS instructions.

No.2347-7 - Polished trap door without bearings or retainers. Use on any Big Twin 5-Speed 1980-06.

No.2347-7C - Chrome trap door without bearings or retainers. Use on any Big Twin 5-Speed 1980-06.

**CHROME**

### TRAP DOOR ASSEMBLIES WITH EXHAUST MOUNT FOR SMALL BEARING #8998

Small bearing trap doors were originally used on all Big Twins 1980-98. For more details see No. 2347-IS instructions.

No.2347-7B - Polished trap door with installed bearings and retainers. Use on any Big Twin 5-Speed 1980-98.

No.2347-7CB - Chrome trap door with installed bearings or retainers. Use on any Big Twin 5-Speed 1980-06.

**CHROME**

### TRAP DOORS ASSEMBLIES WITH EXHAUST MOUNT FOR BIG BEARING #8992

Big bearing trap doors were originally used on all Big Twins 1999-06 5-speeds. For more details see No. 2326-IS instructions.

No.2326B - Polished trap door with installed bearings and retainers. Use on any Big Twin 5-Speed 1980-06.

No.2326CB - Chrome trap door with installed bearings and retainers. Use on any Big Twin 5-speed 1980-06.

**CHROME**

**NOTE:** Use JIMS® Tool No.2283 or No.1014 to remove door assembly.

### TRAP DOORS ASSEMBLIES WITHOUT EXHAUST MOUNT FOR BIG BEARING #8992

Big bearing trap doors were originally used on all Big Twins 1999-06 5-speeds. For more details see No. 2326-IS instructions.

No.2327B - Polished trap door with installed bearings and retainers. Use on any Big Twin 5-Speed 1980 to 2006 or all 4/5 Speed transmissions.

No.2327CB - Chrome trap door with installed bearings and retainers. Use on any Big Twin 5-Speed 1980 to 2006 or all 4/5 Speed transmissions.

**CHROME**

### TRAP DOORS WITHOUT EXHAUST MOUNT FOR SMALL BEARING #8998

Small bearing trap door without exhaust mount hole were originally used on 1994-1998 FLT. For more details see No. 2347-IS5 instructions.

No.2347-75C - Chrome trap door without bearings or retainers. Use on any Big Twin FLT 5-Speed 1994-98, or all 4/5 Speed transmissions.

**CHROME**



**NEW**



Black Anodized



## JIMS HANDCRAFTED TRANSMISSION SIDE COVER

These new billet transmission side covers come with the latest look, Raw Cut & welded. They come to you plated with a Bright Dipped or Black Anodized finish. The cover has a handcrafted look, combined with a clean precision cut fin pack & add in some welded accents make these pieces the latest in style. Gaskets & screws included. Order a JIMS Cam cover No. 2300 to match up with & you'll be No. 1. See page 68. Screws and gaskets included for No. 2394, 2395, 2396, 2398.

No. 2395 - Use on all 2006 to present H-D Cruise Drive 6-speed transmissions Bright Dipped Anodized.

No. 2396 - Black Anodized.

No. 2394 - Use on all 1987 to 2006 Big Twin 5-Speed transmissions and aftermarket 6-speeds with a minor hardware change. (Not for FXR with controls.) Bright Dipped Anodized.

No. 2398 - Black Anodized.



## JIMS® BILLET TRANSMISSION TOP COVER

JIMS® Billet aluminum transmission top cover is made from 6061-T6 aircraft quality aluminum. Covers come with gasket and chrome allen screws. Replaces OEM No.(chrome) 34468-98 or No.(polished) 34464-98.

No.8999PK - (Polished kit) Use on 1998-1999 FLH and Softail® and 6-speed models.

No.8999CK - (Chrome kit) Use on 1998-1999 FLH, Softail®, and 6-Speed models.

**CHROME**

**NOTE:** Will fit 1987-97 FLH and FXST models when using H-D® No.33902-98 switch and H-D® No.33320-98 shifter drum.



## CHROME BILLET TRANSMISSION SIDE COVER KIT

This precision machined billet cover is made of 6061-T651 aluminum and is designed to reduce the amount of flex force, as seen in most end covers when using either a stock or high pressure clutch spring. Includes six chrome allen screws, inner and outer ramp, three ball bearings, snap-ring, coupler, chrome allen dipstick with o-ring, and gasket. For more details see No. 2371-IS instructions.

No.2371CK - Chrome with ball ramp release, gaskets and screws. Use on all 5-speed models. 1987-2006. (except FXR with mid controls) May be used on aftermarket 6-Speed if using 6-Speed hardware.

**CHROME**



## BILLET CLUTCH END RELEASE COVER

This billet clutch release end cover is precision machined and comes polished or chrome. This very clean and light end cover is designed to reduce the amount of flex force as seen in most end covers, when using either a stock or high pressure clutch spring. Includes gaskets and screws. For more details see No. 2371-IS instructions.

No.2371CH - (Chrome) Use on all 5 speed models. (May be used with aftermarket 6-speed by using different hardware.) 1987- 2006, (except FXR with mid controls.)

**CHROME**

No.2371P - (Polished) Use on all 5-Speed models 1987- 2006. (Except FXR with mid controls.) (May be used with aftermarket 6-speed by using different hardware.)

# 5 SPEED PRECISION-CUT FORGED GEARS

## COUNTERSHAFT GEARS

## MAINSHAFT GEARS



### 4<sup>TH</sup> GEAR COUNTERSHAFT

No.35625-79B -

Use on Big Twin 1980-2006 5 Speed transmissions.

19T



### 4<sup>TH</sup> GEAR MAINSHAFT

No.8294 -

Replaces 35028-79B. Use on Big Twin 1980- 2006 5-Speed transmissions.

29T

MATES WITH



### 1<sup>ST</sup> GEAR COUNTERSHAFT

No.35622-79C -

Use on Big Twin 1980-2006 5-Speed transmissions.

31T



### 1<sup>ST</sup> GEAR MAINSHAFT

No.35025-79B -

Use on Big Twin 1980-2006 5-Speed transmissions

18T

MATES WITH



### 3<sup>RD</sup> GEAR COUNTERSHAFT

No.8291 -

Replaces 35026-79C. Use on Big Twin 1980-2006 5-Speed transmissions.

23T



### 3<sup>RD</sup> GEAR MAINSHAFT

No.8292 -

Replaces 35027-79B. Use on Big Twin 1980-2006 5-Speed transmissions

27T

MATES WITH



### 2<sup>ND</sup> GEAR COUNTERSHAFT

No.8292 -

Replaces 35027-79B. Use on Big Twin 1980-2006 5-Speed transmissions

27T



### 2<sup>ND</sup> GEAR MAINSHAFT

No.8291 -

Replaces 35026-79C. Use on Big Twin 1980-2006 5-Speed transmissions.

23T

MATES WITH



### 5<sup>TH</sup> GEAR COUNTERSHAFT

No.8299 -

Replaces 35626-79B. Use on Big Twin 1980-2006 5-Speed transmissions

17T

MATES WITH



### LATE 5<sup>TH</sup> GEAR MAINSHAFT

Replaces 35029-91A. Bearing and seal installed. Requires a mainshaft with a bearing diameter of .9845". Use this gear with mainshaft No.35042-91 for the 1990 model year.

No.8296 -

Use on Big Twin 1991-2006 5-Speed transmission.

32T

### EARLY 5<sup>TH</sup> GEAR MAINSHAFT

Replaces 35029-85A. Bearing and seal installed. Requires a mainshaft with a bearing diameter of 1.000".

No.8297 -

Use on Big Twin 1985-90 5-Speed transmission.

32T

### EARLY 5<sup>TH</sup> GEAR MAINSHAFT

Replaces 35029-79. Bearing and seal installed. Requires mainshaft with a bearing diameter of 1.000".

No.8298 -

Use on Big Twin 1979-84 5-Speed transmission.

32T

**NOTE:** Use JIMS® Tool No.35316-80 to remove and install 5th gear, mainshafts.

**25T                      16T**

**FIRST GEAR 2.94:1 CLOSE RATIO SET**

Makes first gear higher for lighter bikes and high performance motors, for more m.p.h. in first gear. Ramping has been machined in for cleaner and more positive shifting. For more details see No. 2220-IS instructions.

No.2220 - Use on Big Twin 1980-2006 5-Speed transmission. Fits Twin Cam 88®

(2 piece gear set, 35025-CR first gear mainshaft, 35622-CR first gear countershaft)



## COMPLETE 5 SPEED PRECISION-CUT FORGED GEAR SETS

JIMS® forged and shot peened gears sets and heat treated shafts come unassembled and ready to install in your stock or aftermarket 5-speed case. Gear sets are available with either a close ratio first gear 2.94:1, or standard ratio first gear as an option. For more details see No. 8015-IS instructions.

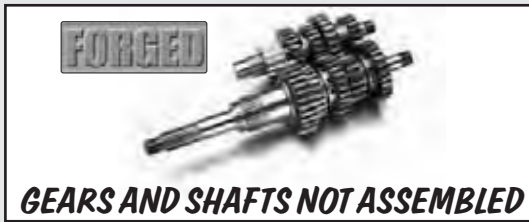

APPLICATION	STD RATIO	CLOSE RATIO
1980-1984	No.8044	No.8045
1985-1989	No.8046	No.8047
1990-2006	No.8015	No.8016

**NOTE:** Use JIMS® Tool No.2189 to install these shaft assemblies into trap doors.



### 5-SPEED MAINSHAFT

Use this mainshaft with gear No.35029-91A for the 1990 year models, bearing diameter area is .9845".

No.35042-91 - Use on Big Twin 1991-2006 5-Speed transmission. May be used on 1990 with main drive gear No.8296.



### COUNTERSHAFT

No.35632-79 - Use on Big Twin 1980-06 5-Speed transmission and Twin cam 88°.

### COUNTERSHAFT - 1/4" SHORTER

This countershaft is identical to JIMS® standard 5-Speed countershaft, above No.35632-79, except modified to work in a JIMS®, Sputhe or C.C.I. 4-5 Speed case which requires a 1/4" shorter countershaft.

No.35632S - Use on JIMS®, Sputhe's or C.C.I.'s special 5-Speed in a 4-Speed, transmission.



### 4-SPEED COUNTERSHAFT

Standard O.D. is .750".

No.35614-80 - Use on Big Twin 1980-86.



### 4- SPEED COUNTERSHAFT

Standard O.D. is .755".

No.35614-65 - Use on Big Twin 1936-76.



### 4-SPEED COUNTERSHAFT

Standard O.D. is .750".

No.35614-76 - Use on Big Twin late 1976-79.



### 5-SPEED MAINSHAFT

Main drive gear bearing diameter area is 1.000".

No.35042-85 - Use on Big Twin 1985-89 5-Speed transmission.



### 5-SPEED MAINSHAFT

Main drive gear bearing diameter area is 1.000".

No.35042-79 - Use on Big Twin 1980-1984 5-Speed transmission.



### 4-SPEED MAINSHAFT

Stock replacement mainshaft for all H-D® and aftermarket 4-Speed transmissions.

No.35039-80 - Use on Big Twin 70-Early 84 4-Speed transmission.

## FAT TIRE GEAR & MAINSHAFTS



### 5-SPEED MAINSHAFT +1" LONGER

This mainshaft is designed for use on Fat Rear Tire bikes. Must be used with JIMS No. 8099 1" longer Maindrive gear and No. 8299 countershaft 5th gear. No.0178-1010 - Use on Big Twin 1991-2006 5-Speeds.



### AFTERMARKET 6-SPEED MAINSHAFT +1" LONGER

This mainshaft is designed for use on Fat Rear Tire bikes. Must be used with JIMS No. 8099 1" longer Maindrive gear and No. 8299 countershaft 5th gear. No.0178-1033 - Use on Big Twin 1991-2006 5-Speeds.



### 5 & 6 SPEED +1" LONGER MAINDRIVE GEAR

This drive gear is designed for use on Fat Tire bikes. Can be used with JIMS No.0178-1010 1" longer Mainshaft for 5-Sp or JIMS No.0178-1033 for 6-Sp 1" longer Mainshaft.

No. 0178-1011 - Use on Big Twin 1991-'06 5-or aftermarket 6-speeds.





**NEW**



## INNER PRIMARY BEARING UPGRADE KIT

Thinking of running an open primary system, or looking for added durability in your high output engine? JIMS now has a new double row ball bearing with seal and retaining ring kit. Remove stock primary bearing with JIMS Tool No. 967 and remove bearing race from main shaft with JIMS Tool No. 34902-84. For more details see No. 8960-IS instructions.

No. 8960 - Use on 1990 to 2006 FLH & FXST, and on 1990 to 2005 Dyna models or any 5 or aftermarket 6-speeds using H-D bearing No.9135 (capatiable with Bandit clutch kits).

**NEW** No. 8961 - Seal for No.8960 kit above.



## SPLIT NEEDLE BEARING

Mainshaft - Countershaft bearing, 4 used per transmission - **Sold Individually.**

No.8876A - Use on all Big Twin 5-Speeds, or aftermarket 6-Speeds, 1980-2006.



## LATE 4-SPEED BIG TWIN AND SPORTSTER® COUNTERSHAFT BEARING

American made by Torrington. For the best results install bearing with JIMS® Countershaft Bearing Tool No.34733-77.

No.35961-52 - Use on Big Twin Late 1977-84, 2 per transmission. Use on Sportster® 1954-1984, 2 per trans. Use on Sportster® 1985-1990, 3 per trans. Use on Buell 1987-90, 3 per transmission.



## LATE 4-SPEED BIG TWIN MAIN DRIVE GEAR BEARING

American made by Torrington. For the best results install bearing with JIMS® Transmission Main Drive Gear Bearing Tool No.33428-78.

No.8905 - Use on Big Twin Late 1977-81.



## CLOSED END SPORTSTER® COUNTERSHAFT CASE BEARING

American made by Torrington.

No.35960-54 - Use on Sportster® and K models 1954-90. Use on Buell 1987-90.



## SPORTSTER® MAINSHAFT RIGHT CASE BEARING

American made by Torrington. Install bearing with JIMS® Mainshaft Bearing Tool No.34810-84.

No.9118 - Use on Sportster® 1984-90. Use on Buell 1987-90.



## CLUTCH RELEASE BEARING KIT

Kit comes with U.S.A. made bearing. Since this kit is made to JIMS® high standards, it ensures proper clutch operation. Replaces H-D® No.'s 37312-75, 37313-80 and 11096.

No.2226 - Use on Big Twin 1975-present 4, 5, and 6-Speed transmissions. Includes Twin Cam® Cruise Drive A and B motors.



## FIFTH GEAR BEARING

Use in fifth gear - 2 per transmission. Install with JIMS® Tool No.34734-80 to the right depth. See "Transmission Tool" section.

No.8904 - Use on Big Twin 1980-90.



## COUNTERSHAFT BEARING

Countershaft end bearing - Primary side.

No.8977 - Use on Big Twin EVO 1980-1999.

Use on 5-Speed Twin Cam® 1999-2006.

Use on Sportster® 1991-2005.

Use on Buell® 1991-2005.



## FIFTH GEAR BEARING

Use in fifth gear - 2 per transmission. Install with JIMS® Tool No.37842-91 to the right depth. See "Transmission Tool" section.

No.35051-89 - Use on all Big Twin 1991-06 FL, FXST and 1991-05 FXR and FXD.

Use on Sportster® 1991-present.

Use on Buell® 1991-present.



## 4 SPEED TRANSMISSION CASE BEARING

Quality mainshaft ball bearing. Manufactured in USA.

No.9020 - Use on Big Twin 1936-86 4-Speed.



## 5-SPEED LATE LARGE DOOR BEARING

Use on all 5 and 6 speed transmissions that use the larger O.D. (2.047") door (H-D® No.8992A) bearing. These bearings support the mainshaft and countershafts from the door side of all JIMS® standard left side drive 5 and 6 speed transmissions, and JIMS® billet doors requiring this large bearing. Use JIMS® Tool No.1014 to remove and install bearings. **Sold in a pack of 2.**

No.8992K - Use on all 1999-2005 FXD and 1999-2006, FXST and FLH.

## 5-SPEED TRAP DOOR BEARING

Use on all 5-Speed transmissions. These



quality American bearings (H-D® No.8998) support the transmission main and counter shafts. Use one on countershaft of Buell® and XL. Use JIMS® Tool No.1014 on Big Twin to remove and install bearings. **Sold in a pack of 2.**

No.8998K - Use on Big Twin 1980-1998 5-Speed transmission, Sportster® 1991-2003.

Use on Buell® 1991-2005.

## 5-SPEED TRANSMISSION CASE MAIN GEAR BEARING

Quality main drive gear transmission bearing, manufactured in USA. This bearing must be replaced whenever the main drive gear is replaced. Use JIMS® tool No.35316-80 on Big Twin, See "Transmission Tool" section. This bearing must be installed with the proper tool. Replaces H-D® No.8996A.

No.8996 - Use on Big Twin Late 1984-2006

5-Speed transmission, also Sportster & Buell 1991 to 2005.

## 5-SPEED TRANSMISSION CASE BEARING

Manufactured in USA, this bearing must be replaced every time the main drive gear is replaced. Use JIMS® No.35316-80 for installing bearing and main drive gear, See "Transmission Tool" section. This bearing must be installed with the proper tool.

No.8978 - Use on Big Twin 1980-Early 1984 5-Speed transmission.





## BIG TWIN 4-SPEED MAIN DRIVE GEAR AND COUNTERSHAFT ROLLER BEARINGS

These rollers are made in the USA to JIMS® specifications from aerospace quality 52100 bearing material. Standard bearing O.D. is  $.125" \times 2" = .250"$ . And with a main drive gear of 1.6290" to 1.6295" you get a total diameter of 1.8790" to 1.8795". For a running clearance of .0005" to .0019", lap case race to a size of 1.8795" (if your total diameter is 1.8790"). If your total diameter is 1.8795" lap to 1.880" and so on for oversize rollers. If using oversize rollers it is ok to leave out 1 roller, from 44 to 43. In some applications 43 rollers is all that will fit without force. Also, use for countershaft bearings with a standard bearing O.D. of  $.125" \times 2" = .250"$ . With a countershaft size of .7545" to .7550" you will have a total diameter of 1.0045" to 1.0050" for a running clearance of .0005" to .0019". Your countershaft gear I.D. should be 1.0050" to 1.069", use oversize as needed.

Sold in packs of 100 pcs.

Use on Big Twin 1936-early 1977 4-Speeds Main Drive Gear.

Use on Big Twin 1936-early 1976 4-Speeds Countershafts.

JIMS® No.	SIZE	O.D.
9084	STD	.1250"
9085	+ .0004"	.1254"
9086	+ .0008"	.1258"
9084A	+ .001"	.1260"



## MAINSHAFT INNER RACE

Inner primary race - pressed on mainshaft. Press on mainshaft with JIMS® Tool No.34902-84.

See "Transmission Tool" section.

No.34091-85 - Use on EVO Big Twin Late 1984-2000. Use on Twin Cam® 1999-2006 5-Speeds or aftermarket 6-Speeds.



## SPORTSTER® 4-SPEED MAINSHAFT END BEARING

These rollers are made in the USA to JIMS® specifications from aerospace quality 52100 bearing material. Sold in packs of 100 pcs.

Use on Sportster® 1952-Early 84.

JIMS® No.	SIZE	O.D.
9095	STD	.1562"
9096	+ .0004"	.1566"
9097	+ .0008"	.1570"



## TRANSMISSION MAIN BEARING RACE

Standard O.D. is 2.314", I.D. is 1.8802". It will depend on the amount of press fit and will determine the amount of line lapping required to fit new bearing and mainshaft.

No.35125-37 - Use on Big Twin 1937-Early 1977.

No.35125-372 - Oversize +.002".

No.35125-375 - Oversize +.005".

No.35125-3710 - Oversize +.010".



## TRANSMISSION MAIN BEARING RACE

Standard O.D. is 1.5635", I.D. is 1.3045". The amount of the press fit in the trans case will determine the amount of line lapping required to fit new bearing and mainshaft. Use JIMS® Tool No.34810-84 to install race.

No.35105-52 - Use on Sportster® and K Model 1954-83.

No.35105-525 - Oversize +.005".



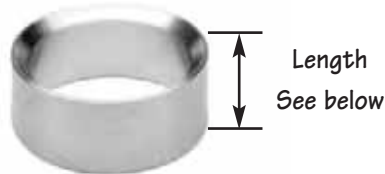

## TRANSMISSION SPROCKET SPACER

Smooth finish for a longer seal life.

No.33334-85 - Use on Big Twin Late 1984-Early 1994 . Use with transmisson seal No.12050, .850" length.

No.33334-79 - Use on Big Twin 1980-Early 1984. Use with transmission seal No.12044A, 687" length.

No.33344-94 - Use on Big Twin 5-Speed or aftermarket 6-Speed. Late 1994-2006. Use transmission seal No.12067A. .600" length.

## MAINSHAFT SPACER



Transmission mainshaft spacer. Made to OEM specs. Spacer fits between the transmission door and mainshaft 4th gear. This spacer has a shoulder on it; the countershaft spacer does not. **Sold in a pack of 5.**

No.35064-79K - Use on Big Twin 1980-2006 5-Speed and aftermarket 6-Speed transmissions.

## COUNTERSHAFT SPACER

Use on countershaft door side (The spacer without the step). **Sold in a pack of 5.**

No.35629-79K - Use on Big Twin 1980-2006 5-Speed and aftermarket 6-Speed transmissions.

## MAINSHAFT & COUNTERSHAFT SPACER



Use between the door bearing, JIMS® No.8998, and JIMS® nut No.35078-79. See "Transmission Tool" section. Use 2 per transmission. **Sold in a pack of 10.**

No.35076-79K - Use on Big Twin 1980-2006 5-Speed transmission.

## MAINSHAFT & COUNTERSHAFT LOCK JAM NUT



Use to lock mainshaft and countershaft to bearing No.8998. Always use a new one if it is being removed. **Sold in a pack of 2.**

No.35078-79K - Use on Big Twin 1980-2006 5-Speed and aftermarket 6-Speed transmissions. Use on Sportster® 1987- 2003 master cylinder. Phone 805-482-6913



## TRANSMISSION DRIVE GEAR BUSHING

After installing JIMS® bushing No.35094-65 with Jims tool remover and installer No.1005, the I.D. of bushing must be honed to size for a running clearance on mainshaft of .0017 to .0025 with a 32 or better finish.

No.35094-65 - Use on Big Twin 1931-86 4-Speed transmission.



## MAINSHAFT GEAR BUSHING

For second and third gears. After installing JIMS® bushing No.35094-65 with JIMS tool remover and installer No.1005, the I.D. of bushing must be honed to size for a running clearance on mainshaft of .0017 to .0025 with a 32 or better finish.

No.35322-38 - Use on Big Twin 1938-Early 1979.



## COUNTERSHAFT GEAR BUSHING

For low and second gears

No.35791-36 - Use on Big Twin 1940-86.

Low and reverse gears

No.35789-36 - Use on Big Twin 1936-86.



## SHIFTER SHAFT BUSHING

**Sold in a pack of 2.**

No.40520-63 - Use on Sportster® 1977-2005. Use on Buell® 1987-2006.



## LATE 5 SPEED DOOR RETAINING RINGS

Use these retaining rings to hold No.8992 JIMS<sup>®</sup> door bearings in place. American made to fit perfectly. **Sold in a pack of 10.** Also replaces H-D<sup>®</sup> No.35087-99.

No.35087-99K - *Use on all 1999-2005 FXD and 1999-2006, FXST and FLH.*

## EARLY 5-SPEED DOOR RETAINING RINGS

Use these retaining rings to hold No.8998 JIMS<sup>®</sup> door bearings in place. American made to fit perfectly. **Sold in a pack of 10.** Also replaces H-D<sup>®</sup> No.11020.

No.11020K - *Use on Big Twin 1980-98 5-Speed transmission. Use on Sportster<sup>®</sup> and Buell 1991-1998.*



## MAIN DRIVE GEAR RETAINING RING

Retains main drive gear bearing in 5-Speed transmission case. **Sold each.**

No.11161 - *Use on Big Twin Late 1984-2006 5-Speed and aftermarket 6-Speed transmissions.*

## MAIN DRIVE GEAR RETAINING RING

Retains main drive gear bearing in early style 5-Speed transmission case. **Sold in a pack of 10.**

No.11057K - *Use on Big Twin 1980-early 1984 5-Speed transmission.*



## MAINSHAFT & COUNTERSHAFT RETAINING RING

Retainers precision made, better than stock, and are used to keep gears in place on bearings. Use JIMS<sup>®</sup> tool No.2362, for removing and installing retainers, See "Transmission Tool" section. **Sold in a pack of 10.**

No.11067K - *Use on Big Twin 5-Speeds and aftermarket 6-Speeds, 1980-2006 transmissions. Use on Sportsters<sup>®</sup> and Buells<sup>®</sup> 1991-present transmissions.*



## THRUST WASHER

Use on 5-Speed transmission shafts where a retainer ring is positioned. Use between gear and retainer ring. For a 5-Speed transmission, washers are .070" thick for the best end play control.

**Sold in a pack of 5.** Use with JIMS<sup>®</sup> tool No.2362, See "Transmission Tool" section.

No.6003K - *Use on Big Twin 5-Speeds and aftermarket 6-Speeds 1980-2006. Use on Sportster<sup>®</sup> and Buell<sup>®</sup> 1991-present.*



## SHIFTER ARM ADJUSTING SCREW

A high quality replacement, made to our highest standards. Fits all 5-Speed transmissions. Hardened to 47-49 Rockwell.

No.33119-79A - *Use on:*

*FL-1979-00; FXR-1982-94 and 1999; FXD-1991-00; FXST-1986-99*



## ADJUSTING ARM SCREW LOCK NUT

Lock (Jam) nut to lock adjusting screw after gear engagement adjustment is set.

**Sold in a pack of 10.**

No.7515K - *Use on:*

*FL-1979-2000  
FXR-1982-1994 and 1999  
FXD-1991-2000  
FXST-1986-1999*

## SHIFTING ASSEMBLY KIT

This kit includes: No.35068-79 plate, No.34087-79 spring, No.34086-79 pawl plate, No.34084-86 shifter shaft, No. 34083-79 spring, No. 34082-79 pin, 6016 washer and 11016 retaining ring.



**NEW IMPROVED!  
LESS PEDAL FREE  
MOVEMENT!**

No.2384 - Use on: *FL-1979-2000  
FXR-1982-1994 and 1999  
FXD-1991-2000  
FXST-1986-1999*



## CHROME TRANSMISSION SHIFT LEVER

This chrome shift lever replaces OEM transmission shift lever No.33715-85.

No.33715-85AC - Use on all Big Twin 5-Speeds, 1985-1996 and aftermarket 6-Speeds, 4/5-Speeds, and 4/5/6-Speed Transmissions.



## CHROME TRANSMISSION SHIFT LEVER

This chrome shift lever replaces OEM transmission shift lever No.33849-79.

No.8360 - Use on all 1997-present Big Twins.



## CHROME SPEEDO SENSOR BLOCK-OFF PLATE KIT

Kit covers hole in transmission cases when speedometer pickup sensor is not installed in case. Kit includes chrome finish steel plate, gasket, and button head chrome allen screw.

No.8042K - Use on all models where OEM speedometer pickup sensor are normally used, Big Twin and Sportster®.

No.8041K - 10 pack of gaskets

## ELECTRONIC SPEEDO SENSOR

Original equipment sensor for 1996 to present FXST for Big Twin Transmission cases

Also fits any aftermarket transmission case with speedo sensor hole.

Complete with o-ring, hardware and OEM connector.

No.74437-96 - Use on all FXST 1996-1999, replaces H-D® No.74437-96

No.74420-94 - Use on FLT 1995-96, and FXD 1995-2005, replaces H-D® No.74420-94



## SPEEDO RE-CALIBRATION

This electronic speed correction module from Dakota Digital will plug into your speed sensor harness to correct the speedo meter and odo-meter after a change in tire size, pulley size or transmission gearing. This unit plugs directly between the stock transmission sensor and stock speedometer. No cutting or splicing is required. This module can correct the speedometer to within 1 MPH from 50% to 200% of the original reading. Manufacturer instructions included.

No.8126 - Use on Softail 1996-2006, Dyna 1996-2005, Sportster 1995-2003, FLH 2006 and earlier with OEM electronic Speedometer.

**NOTE:** 2007 and later Harley models require hardwiring into stock harness, speed correction can be made up to Harley's factory margin of error, typically 3-5% from correct mileage.



## CHROME BILLET SPEEDO SENSOR BLOCK-OFF PLUG KIT

This chrome billet plug kit inserts in the hole in transmission cases when the speedo sensor is not being used. Includes chrome allen screw with o-ring.

No.8102 - Use on all models where O.E.M. speedo pickup sensors are normally used on Big twin and Sportster®.

**NEW** No.8103 - Black Anodized



# SHIFTING PARTS & PILLOW BLOCK

## EARLY TO LATE 5 SPEED SHIFTER UPGRADE KIT

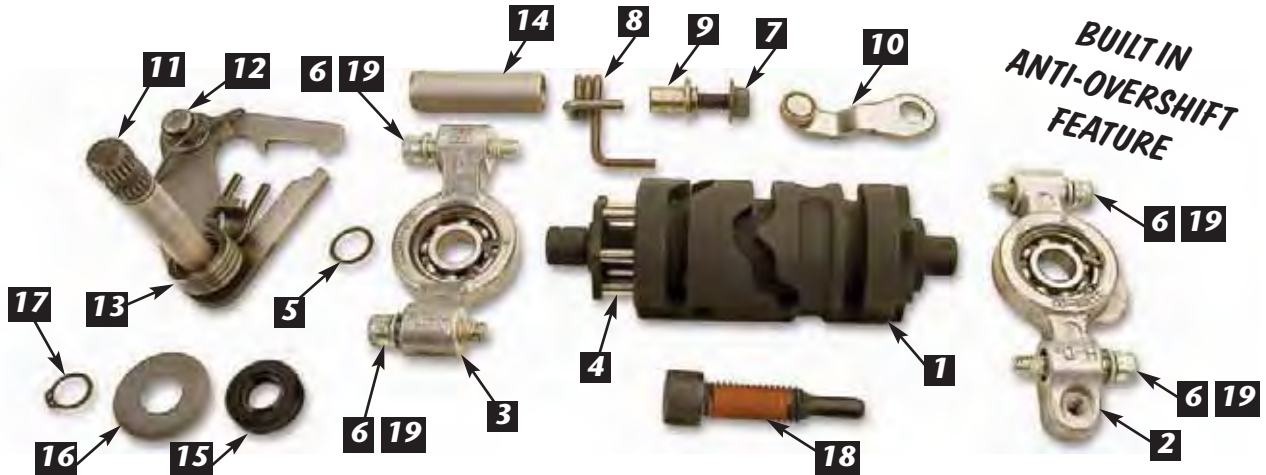

**BUILT IN  
ANTI-OVERSIFT  
FEATURE**

This is a simple upgrade kit to install on all early Big Twin H-D® 5-speed models 1980 - 1999 FXST and 1980 to 2000 FL's and Dyna's. transmissions. Make your early model shift smooth and positive with 5-speeds latest in technology. This kit includes a JIMS® designed shift drum and lever assembly which has a built in anti-oversift feature. Kits come with late model pillow blocks, all necessary hardware, and a case shifter shaft sleeve bushing. Also included are complete installation instructions. For installation of the shifter sleeve item No.14 order JIMS® tool No.1664. For more details see No. 8070-IS instructions.

No.8070 - Use on all Big Twin Shovel and Evo 5-speed models 1980 to 1999 FXST and 1980 to 2000 FL's and Dyna's.

### PARTS AVAILABLE SEPARATELY

NO.	QTY.	DESCRIPTION	PART NO.
1	1	SHIFT DRUM	8080
2	1	RIGHT PILLOW BLOCK	33304-00
3	1	LEFT PILLOW BLOCK	33301-00A
4	6	SHIFT DRUM DOWEL PIN	8356
5	1	SHIFT DRUM RETAINER	11342
6	4	SCREW, SHCS 1/4-20" x 1-1/4"	2135
7	1	SCREW, DETENT ARM	33376-00
8	1	SPRING, DETENT ARM	33374-00
9	1	SLEEVE, DETENT ARM SPRING	33375-00A
10	1	DETENT FOLLOWER ASSEMBLY	33364-00A

### PARTS AVAILABLE SEPARATELY

NO.	QTY.	DESCRIPTION	PART NO.
11	1	SHIFTER LEVER	8324
12	1	SPRING, RATCHET ARM	34977-02A
13	1	SPRING, CENTERING SHIFT LEVER	34064-00C
14	1	SLEEVE, SHIFTER SHAFT	7514
15	1	SEAL, SHIFTER SHAFT	12045
16	1	WASHER	6497HW
17	1	RETAINER, SHIFTER SHAFT	11150
18	1	CENTERING SCREW	34978-00A
19	4	WASHER, PILLOW BLOCK SCREW	1215
20	1	INSTRUCTION SHEET	8070-IS



### SHIFT FORK SHAFT

No.34140-36 - Use on Big Twin 1936-79.



### 5-SPEED SHIFT FORK SHAFT

No.34088-87 - Use on Big Twin 5-Speeds and after-market 6-Speeds 1987-2006.



### SHIFT FORK SHAFT KIT

Kit includes O-ring and retaining ring.

No.34186-76 - Use on Big Twin 1936-86.

No.2181K - O-Ring for shafts No.34140-36 and No.34186-76. Sold in a pack of 10.

No.2182K - Snap ring for shaft No.34186-76. Sold in a pack of 10.



### SOLID BILLET LEFT PILLOW BLOCK

Replaces H-D® No.33326-79A. Includes: bearing No.9115. This is it, the one to use for extreme shifting. If you are building an automatic 5-Speed transmission or have back cut gears for super quick shifting, this pillow block is a must, at several times the strength of stock units. Will work on 6-Speeds.

No.2528 - Use on:

FL-1979-2000; FXR-1982-1994 and 1999; FXD-1991-2000; FXST-1986-1999

# DRIVE PULLEYS & MEGA NUTS

## PULLEY & SPROCKET MEGA NUT

JIMS now offers both early and late Mega Nuts. Once you install these left handed threaded nuts correctly they won't come loose with this exclusive lock plate design. They can also be used on BDL sprockets also. When using these nuts install using JIMS socket tool No. 946600-37A on early mega nuts and for late use No. 989 along with No. 2260 pulley locker. Some aftermarket pulleys and sprockets may need to be drilled and tapped. *For more details see No. 1733-IS instructions.*



**No. 1733** – Use on all H-D 6-speed Cruise Drive Transmissions  
 2006 – present FXD's and  
 2007 – present FLH's and  
 FXST's . Also fits BDL sprockets for H-D 6-Speeds.



**No.1708** - Use on all 91-present XL's. Use on 1985-2006, FL FXST, and FXR. Use on 1985-2005, FXD, and JIMS® 6-Speed.

## TRANSMISSION PULLEY NUT



1 - 1/2" - 24 Left Hand Thread. Use with JIMS® 94660-37A socket tool.  
**No.35211-91B** - Use on Big Twin 4 and 5-Speed or aftermarket 6-Speed 1936 to 2006. (Check for inner primary clearances on 4-Speeds).

## JIMS® TRANSMISSION BELT DRIVE PULLEYS



JIMS® steel belt pulleys are made from premium grade aerospace material, thus you get a more durable, longer lasting product.

Stock 5-speed Big Twins come with 32 tooth pulleys. Will also work with aftermarket 6-speed. Not for use on H-D Cruise Drive 6-Speed.



\*Steel Pulley kits come with correct spacer, seal, and Mega nut. See parts list below:

JIMS® No.	DESCRIPTION
No.12067A	Seal
No.33344-94	Spacer
No.1708	Mega Nut Kit
No.11165	Quad Seal

Trans Pulley	Rear Wheel Pulley	Secondary Ratio	Overall Ratio (1.54 primary)	Overall Ratio (1.44 primary)
32T	70	2.19	3.37	3.15
32T	65	2.13	3.27	3.06
32T	61	2.10	3.13	2.92
34T	70	2.06	3.17	3.00
34T	65	1.91	2.94	2.75
34T	61	1.79	2.76	2.58

\*No.40250-94AK - Use on all Big Twins, Steel 32 tooth, kit, 1985-2006 FL, FXST, and FXR, 1991-2005 FXD.

\*No.5001K - Use on all Big Twins, Steel 34 tooth, kit, 1985-2006 FL, FXST, and FXR, 1991-2005 FXD.

No.40250-94A - Use on all Big Twins, Steel 32 tooth pulley only, Includes 1999-2006 FL, FXST, and FXR, 1991-2005 FXD.

No.5001 - Use on all Big Twins, Steel 34 tooth pulley only, Includes 1999-2006 FL, FXST, and FXR, 1991-2005 FXD.

# OFFSET SPROCKETS & KICKER COMPONENTS



## KICK STARTER SHAFT

Redesigned for added strength.

No.33096-54B - Use on Big Twin 1937-86 4-Speeds.



## LONGER KICK STARTER SHAFT

For a cleaner, safer, kicker system, this starter shaft will eliminate the need for a fold out kicker arm. 3/4" longer design to give the needed kicker arm to exhaust clearance.

No.33096-54AL - Use on Big Twin 1937-86 4-Speeds for big tire users with offset transmission kit.



## KICKER GEAR BUSHING

Standard O.D. is .907" - Domestic.

No.33438-501 - Use on Big Twin 3 and 4 Speeds.

Standard O.D. is .925" - Imported.

No.33438-502 - Use on Big Twin 3 and 4 Speeds.



## 4-SPEED KICKER SHAFT BUSHING

O-ring included. Standard O.D. is .940".

Sold in a pack of 2.

No.33288-37 - Use on Big Twin 1937-86.

No.33288-375 - Oversize +.005".

No.2183K - O-ring for kicker shaft (Sold in a pack of 10).

## JIMS OFFSET SPROCKETS BY P.B.I.



These precision "American Made"

sprockets are designed to provide more clearance to drive your fat tire motorcycles. They're made from nickel chromoly #8620 case hardened steel. They are compatible with H-D® #33334-94 spacer, #12067A seal and #11165 quad seal. Use JIMS® No.1708 Mega Nut to secure to main drive gear. Use on all Big Twin 5-Speed transmissions and aftermarket 6-Speeds 1994-2006.

No.5100 - .25 offset 23T.

No.5101 - .25 offset 24T.

No.5102 - .50 offset 23T.

No.5103 - .50 offset 24T.

No.5104 - .810 offset 23T.

No.5105 - .810 offset 24T.

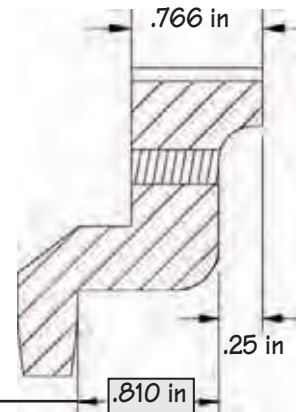

Example of a typical offset



## KICK STARTER BUSHING

Standard O.D. is .8805".

No.33099-52A - Use on Sportster® 1954-85.



## KICKER GEAR BUSHING

No.33442-73 - Use on Sportster® Late 1973- Early 1981.

WHILE SUPPLIES LAST



## KICKER GEAR BUSHING

No.33442-57A - Use on Sportster® 1952-Early 1973.



## JIMS® EXTREME SEALING TECHNOLOGY (EST™) HIGH PERFORMANCE GASKETS



JIMS® introduces EST™ (Extreme Sealing Technology), a new breed of High Performance Gaskets for Harley-Davidson® Evo / Motors. EST™, the Ultimate in gasket sealing technology, is fabricated with an embossed stainless steel metal substrate coated with a proprietary high temperature rubber-like material that virtually eliminates leakage when joining two metal surfaces. EST™ gaskets are available in Complete, Top End and Rocker Box Kits for Twin Cam®, Evo Big Twin, Sportster® and Buell® applications. See JIMS® gasket locator tools No.968 on page 189. For stroke kit gaskets see page 26.

### COMPLETE ENGINE GASKET KITS

Kits include all oil seals and o-rings necessary for a complete engine rebuild, or build up.  
The following applications are available:



#### EVO SPORTSTER® ENGINE GASKET KITS

PART NO.	APPLICATION	OEM NO.	EST KIT
No.824	Use on Evo XL 1200 and Buell® 1991-2003	17026-91A	*EST Kit
No.826	Use on Evo XL 1100 1986-87	17026-86A	*EST Kit
No.827	Use on Evo XL 883 1991-2003	17026-91A	*EST Kit
No.828	Use on Evo XL 883 1986-90	17026-86	*EST Kit

#### SHOVELHEAD / PANHEAD ENGINE GASKET KITS

PART NO.	APPLICATION	OEM NO.	EST KIT
No.831	<small>WHITE SUPPLIES FIRST</small> Use on Shovelhead 4-Speed 1966-69	17029-66	N/A

#### IRONHEAD SPORTSTER® ENGINE GASKET KITS

PART NO.	APPLICATION	OEM NO.	EST KIT
No.833	<small>WHITE SUPPLIES FIRST</small> Use on Sportster® 1977-85	17026-79	N/A
No.834	<small>WHITE SUPPLIES FIRST</small> Use on Sportster® 19L73-76	17026-73	N/A
No.835	<small>WHITE SUPPLIES FIRST</small> Use on Sportster® 1972-E73	17026-72	N/A



Lorán Whittaker



Troy Snider

## TOP END ENGINE KITS

These kits provide all the gaskets needed for the top end build up, or rebuild, starting from the cylinder base gaskets to the complete rocker box assembly.

### THIS KIT FEATURES:

- Intake, power valve and base gasket material manufactured from premium fuel resistant material that will not creep, crack or become brittle. No additional sealants are required for installation.
- The exhaust gasket material consists of a steel reinforced core that prevents blow-outs and burning.
- The head gasket materials that surrounds the core will withstand heat and control the movement caused by the rapid contraction and expansion of exhaust temperatures.
- Our CFM-20 is a perforated steel core gasket, which allows heat to be drawn away from the combustion ring while dissipating heat evenly across the gasket surface. Hot spots that lead to head gasket failure are eliminated.
- CFM-20 elastomer surface provides maximum sealing characteristics and provides sealing around passages that carry oil and coolants.

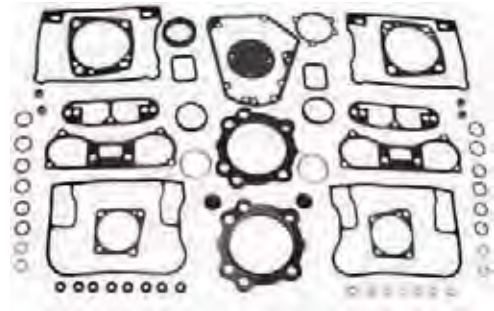

### TWIN CAM® 4" BIG BORE HEAD AND BASE GASKET KITS

PART NO.	MODEL/YEAR	BASE/HEAD THICKNESS	EST KIT
No.857	Use on Twin Cam® 1999-Present	0.02"/0.04"	*EST Kit

### TWIN CAM® 4 1/8" BIG BORE HEAD AND BASE GASKET KITS (4 1/8" STOCK BOLT PATTERN)

PART NO.	MODEL/YEAR	BASE/HEAD THICKNESS	EST KIT
No.873	Use on Twin Cam® 1999-Present	0.02"/0.04"	*EST Kit

### TWIN CAM® TOP END GASKET KITS

PART NO.	MODEL/YEAR	OEM NO.	EST KIT
No.837	Use on Twin Cam® and 1999-Present	17052-99	*EST Kit

### EVO TOP END GASKET KITS

PART NO.	MODEL/YEAR	OEM NO.	EST KIT
No.838	Use on Evo Big Twin 1992-99	17040-92A	*EST Kit
No.839	Use on Evo Big Twin 1984-91	17033-83A	*EST Kit

### EVO XL TOP END GASKET KITS

PART NO.	MODEL/YEAR	OEM NO.	EST KIT
No.840	Use on Evo XL 1200 and Buell® 1991-2003	17032-91	*EST Kit
No.841	Use on Evo XL 1100 1986 and 87	17030-86A	*EST Kit
No.842	Use on Evo XL 883 1991-Present	17030-89A	*EST Kit
No.843	Use on Evo XL 1200 1988-90	17030-88A	*EST Kit
No.844	Use on Evo XL 883 1986-90	17030-86B	*EST Kit

## COMPLETE ROCKER COVER KITS

These kits provide all the gaskets needed for the build up, or rebuild of the rocker box assembly. EST™ – Rocker Box Gaskets are .020" thick and have .005" of high temperature rubber on both sides and will not weep, extrude, tear or become brittle over time. These kits are available for the following models.

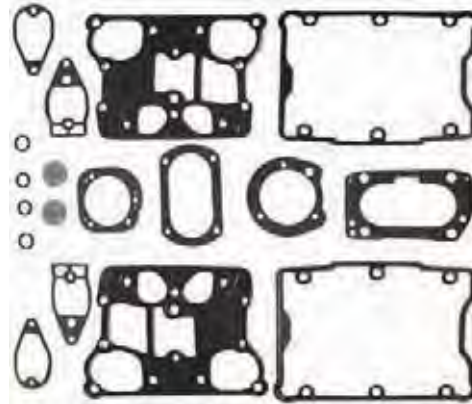

PART NO.	APPLICATION	OEM NO.	EST KIT
No.851	Use on Twin Cam® 1999-Present	N/A	*EST Kit
No.852	Use on Evo Big Twin Single Cam 1992-99	17042-92	*EST Kit
No.853	Use on Evo Big Twin 1984-91	17038-90	*EST Kit
No.854	Use on Evo XL, Buell® 1991-2003	17030-91	*EST Kit
No.855	Use on Evo XL 1986-90	17030-89	*EST Kit

## INDIVIDUAL 10-PACK GASKETS (ENGINE)

These gaskets are conveniently packaged in packs of ten, giving you the flexibility to purchase the gaskets you use most. See our gasket description to learn more about the many benefits that can be expected from these gaskets. These kits are available for the following applications.



PART NO.	APPLICATION	OEM NO.	EST KIT
No.2359K	Use on Front Tappet Block, Big Twin Single Cam 1948-1999	18634-48C	N/A
No.2358K	Use on Rear Tappet Block, Big Twin Single Cam 1948-1999	18633-48D	N/A
No.25225-70BK	Use on Cam Cover, Big Twin 1970-92	25225-70B	N/A
No.25225-93K	Use on Cam Cover Big Twin Single Cam 1993-99	25225-93	N/A
No.1268K	Use on Oil Pump Body, Big Twin 1980-91	26273-80B	N/A
No.1270K	Use on Oil Pump Body, Big Twin Single Cam 1992-99	26273-92	N/A
No.1269K	Use on Oil Pump Cover, Big Twin 1980-91	26276-80B	N/A
No.1271K	Use on Oil Pump Cover, Big Twin Single Cam 1992-99	26276-92	N/A
No.32591-70K	Use on Points Cover Single Cam 1970-99	32591-70	N/A

### EARLY CAM COVER GASKET

Use on Big Twin 1970-92, precision made to fit perfectly. This gasket is included when ordering the JIMS® cam cover. Sold in a pack of 10.

No.25225-70BK -

Use on Big Twin single cam only 1970-92.

(NOTE: Includes aftermarket engines.)

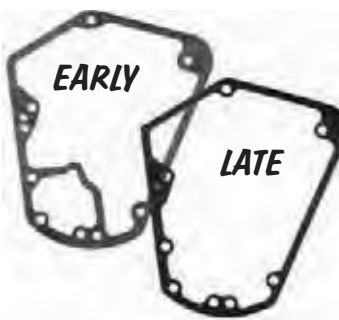

### LATE CAM COVER GASKET

Sold in a pack of 10. This gasket is included when ordering the JIMS® cam covers.

No.25225-93K -

Use on Big Twin single cam only 1993-99.

(NOTE: Includes aftermarket engines.)



## TRANSMISSION GASKETS KITS

These kits provide all the gaskets, seals, nylon washers, and O-rings needed for the build up, or rebuild of a Big Twin transmission assembly. These are the same gasket kits used by JIMS' transmission assembly department. These kits are available for the following applications:

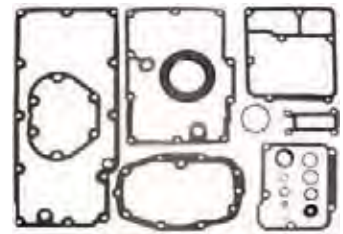

NEW  
NEW  
NEW

NEW  
NEW  
NEW

PART NO.	APPLICATION
No.881	Use on all FLH 6-sp Touring models for 2007 to present
No.882	Use on all FXD 6-sp for 2006 to present
No.883	Use on all FXST 6-sp models for 2007 to present
No.804	Use on Big Twin 5 or aftermarket 6-Speed 1999-2005 FXD, 1999-2006 FL, 2000-2006 FXST
No.803	Use on Big Twin 5 or 6-Speed 1991-98
No.802	Use on Big Twin 5-Speed 1980-90
No.801	Use on Big Twin 4-Speed Late 1979-86
No.800	Use on Big Twin 4-Speed 1936 to Early 1979
No.816	Use on 5-Speed Case 4/5 or 4/5/6 Speed, Electric Start only.
No.890	Use on JIMS Right Side Drive, Mechanical Clutch
No.891	Use on JIMS Right Side Drive, Hydraulic Clutch
No.892	Use on JIMS FAT - 5
No.893	Use on Screamin' Eagle 6-Speed

## STEEL BACKED CAM SEAL THE BEST ONE AVAILABLE - BAR NONE

American made cam cover seal, surpasses and replaces O.E.M. No.83162-51. Use JIMS® Tool No.2243 to remove and install seal. For a no leak fit, seal has a locking compound around the outside diameter to help seal the cam seal to the cam cover.



No.2169 - Use on Big Twin single cam only 1970- 99. (**NOTE:** Includes aftermarket engines.)

## 5-PACK TRANSMISSION MAINSHAFT SEALS

These seals work on all 4, 5 and 6-Speed transmission cases. Sold in packs of 5.



PART NO.	APPLICATION	OEM NO.
No.12013AK	Use on 1965-early 66, and Late 1981-86 Big Twin Models - Main Drive Gear Seal	12013A
No.12035AK	Use on 1991-06 Big Twin, 5 or aftermarket 6-Speed - Main Drive Gear Seal	12035A
No.817K	Use on 1936-79 (4-Speed Main Drive Case Seal)	35230-39

## INDIVIDUAL 10-PACK GASKETS (TRANSMISSION)

These gaskets are conveniently packaged in packs of 10 giving you the flexibility to purchase the gaskets you use most. These kits are perfect for stocking your shelves with fast moving items. They are available for the following applications:



PART NO.	APPLICATION	OEM NO.
No.35652-79K	Use on Trap Door, 5 and aftermarket 6, 4/5, and 4/5/6 Speed 1980-06	35652-79
No.36801-87K	Use on Side Cover, 5 and aftermarket 6, 4/5, and 4/5/6 Speed 1987-06	36801-87A
No.34904-86K	Use on Top Cover, 5 and aftermarket 6, 4/5, and 4/5/6 Speed 1986-99	34904-86
No.8041K	Use on Speedo Sensor Block-off 5 and aftermarket 6-Speed 1995-06	N/A



**PISTON JET TEST  
STAND  
No. 772**



**AFR SNIFFER  
No. 777**



**MINI VALVE  
SPRING TESTER  
No. 1090**



**SLIM JIM  
FILTER WRENCH  
No. 941**



**O2 SENSOR  
WRENCH  
No. 755**



**STEM NUT WRENCH  
No. 977**



**LIFT CADDY  
No. 776**

# TOOLS



# THE JIMS TOOL SUBMISSION PROGRAM

CREATING THE TOOLS DESIGNED BY YOU, THE V-TWIN MECHANIC.

## THE JIMS® TOOL SUBMISSION PROGRAM

JIMS is at the forefront of designing and manufacturing speciality tools for use on Harley-Davidson® Motorcycles. For many years, JIMS has offered tool solutions to make your work easier, faster and safer. The JIMS R&D department prides themselves on creative thinking, when it comes to tool design - and our manufacturing facility backs that up with tools that are warranted for life.

What happens when you, the end mechanic, have a great idea for a tool but, have nowhere to go... Look no further, introducing the tool submission program. Often times, we have people like you, who want to bring ideas to JIMS - but are unsure of what the process and/or compensations are. We figured we'd put it in black and white. If your looking to get rich quick, from a tool idea, than this process is not for you. If you simply want to present an idea, and possibly see it in the JIMS catalog - it doesn't get any easier than this...

Put together your ideas by whatever means you have, be it - drawing sketches, writing a detailed description of how the tool works and why it's valuable, send prototypes, etc... Send these ideas to:

TOOL SUBMISSION PROGRAM  
JIMS R&D DEPARTMENT  
555 DAWSON DRIVE  
CARMARILLO, CA 93012

By doing this, you are authorizing JIMS to evaluate designing and or adding your tool to the JIMS product line. If your tool is selected for a JIMS new product, you will receive 1 of the tools free, after it is processed through production, along with \$250 towards JIMS parts and tools - along with a catalog mention of you as the inventor in the description of the tool in the JIMS catalog.



TRANS SLEEVE INSTALLER &  
REMOVER No. 1658



B MOTOR SUPPORT BLOCKS  
No. 916



FORK ITEM WRENCH  
No. 977

TOOLS THROUGH  
SUBMISSION!



# NEW TOOL QUICK REFERENCE SECTION TABS PAGE

<b>ACCELERATOR SOFTWARE TOOL .....</b>	<b>1</b>
<b>TAPPET PUMP UP &amp; PISTON JET TEST STAND TOOLS .....</b>	<b>2</b>
<b>LIFT CADDY &amp; VALVE SPRING TESTER TOOL .....</b>	<b>3</b>
<b>TIMKEN TOOL TOOLS .....</b>	<b>4</b>
<b>FUEL INJECTION TOOLS .....</b>	<b>5</b>
<b>DIAGNOSTIC TOOLS .....</b>	<b>6</b>
<b>IGNITION , FUEL PUMP, &amp; ELECTRICAL TOOLS .....</b>	<b>7</b>
<b>VALVE TRAIN TOOLS .....</b>	<b>8</b>
<b>CAM TOOLS .....</b>	<b>9</b>
<b>TAPPET BLOCK &amp; ROD TOOLS .....</b>	<b>10</b>
<b>WRIST PIN &amp; PISTON TOOLS .....</b>	<b>11</b>
<b>CYLINDER TOOLS .....</b>	<b>12</b>
<b>CASE BORING &amp; LAPPING TOOLS .....</b>	<b>13</b>
<b>TWIN CAM BALANCER TOOLS .....</b>	<b>14</b>
<b>FLYWHEEL &amp; CRANKSHAFT BEARING TOOLS .....</b>	<b>15</b>
<b>LEFT CASE TOOLS .....</b>	<b>16</b>
<b>PINION GEAR TOOLS .....</b>	<b>17</b>
<b>OIL PUMP, FILTERS, &amp; ENGINE DIPSTICK TOOLS .....</b>	<b>18</b>
<b>CLUTCH &amp; PRIMARY DRIVE TOOLS .....</b>	<b>19</b>
<b>PULLEY &amp; TRANSMISSION TOOLS .....</b>	<b>20</b>
<b>FORK, NECK, &amp; FRAME TOOLS .....</b>	<b>21</b>
<b>AXLE, CHAIN, BELT, WHEEL, BRAKE, STAND &amp; JACK TOOLS .....</b>	<b>22</b>
<b>ENGINE PLUG KIT .....</b>	<b>23</b>
<b>GENERAL TOOLS &amp; MANUALS .....</b>	<b>24</b>
<b>CHEMICALS, LUBRICANTS, &amp; SUPPLYS .....</b>	<b>25</b>
<b>CLOTHING .....</b>	<b>26</b>

## ACCELERATOR FOR WINDOWS™ SOFTWARE

Are you looking for a turnkey software solution for computer generated V-Twin engine simulation software? Then the new version of Accelerator For Windows is the answer! Thousands of Accelerator users have benefitted from the original versions of Accelerator Pro.

The biggest advantage to the new version of Accelerator is that it's now compatible with Windows. This program is easy-to-use, and ideal for the home user.

Resources for the program include over 200 different camshaft profiles, or you can easily change cylinder head airflow, import cylinder head gains "or" losses. You can easily save the engine combinations for future reference.

Confused about gearing ratios? Not anymore - this new Accelerator has a gearing program that will figure out sprocket and belt combinations in every RPM.

Accelerator graphically displays horsepower, torque, CFM, camshaft timing, etc... Advance features include: The ability to calculate compression ratios; adjustments for dome or flat top pistons; configure cylinder, pushrod and manifold lengths.

Finally, you can check your engine combination's performance in the 1/4 mile, and figure a price tag on the engine or performance upgrades. Accelerator For Windows is the answer to the enthusiast that is looking for a certain performance target before investing in a single product.

### ADDITIONAL FEATURES OF ACCELERATOR:

**Balance program** - No need for the paper sheets and trying to figure out the math for lower end balancing. This program lets you select balance factors and tells you the bob weights, then saves the combination for future references.

**CFM** - Confused over the different head airflow test procedures? This program converts CFM flow figures from one test pressure to another.

**Utilities**- Check your 1/4 mile times and MPH gains from Nitrous, Turbo and Nitro. Requires IBM compatible, minimum computer 200MHz or faster, minimum 250MB RAM, and 10MB of hard drive space. **Sold on CD only.**

Accelerator is well known for contributing to some of the nations fastest gas burning Harleys® in the world. It has proven itself to be 98-99% accurate and has proven to be the single most important sales generating tool you can have in your shop.

**Compatible with: Windows 98™, SE™, ME™, 2000™, XP™, or VISTA™, 7 both 32 or 64 bit versions Operating systems.** Very much a Windows type program and requires a mouse for all inputs and navigation throughout program. Accelerator For Windows is all new and extremely simple to use with drop down scrolling with data already provided.

Helps in decision making inputs. New code generator will cut calculation time in half which allows for more computing code time, giving more defined answers, and taking more of the guess work out. Accelerator For Windows features the new Dyno program, which will read Dyno Jet files and also allow users to input their own Dyno data. Dyno files can be compared with simulation files or other Dyno runs. Accelerator For Windows has the new animation program that allows running two engines side by side for visual difference in stroke, cam timing, CFM, and rod length.

The best feature of Accelerator For Windows is that its easy to use, but still has the advance features pro engine builders need to be competitive. Accelerator For Windows has the new Twin Cam® engine data and latest camshaft files with "do's and don'ts" for hop-up. All Accelerator For Windows programs include Harley Davidson® Screamin Eagles® stage kit files and horsepower curves with part numbers and pricing for easy customer buying.

**IMPORTANT NOTE:** This is a distributed product. JIMS® does NOT offer any technical support for this product.

No.2343





# PISTON JET, & TAPPET TEST STAND

## TAPPET PUMP AND TEST STAND

With the new Tappet Pump and Test Stand you can now completely fill your standard size hydraulic tappets, physically inspect them and with the help of a drill press, check for proper feel. By using pressurized oil, this unique tool will allow you to fill the tappet with oil, while "feeling" the fitment of the hydraulic unit. You can easily diagnose loose or "spongy" tappets that could eventually lead to bleed down issues, or "sticky" tappets that won't pump up due to poor hydraulic unit fitment. Mechanics can now have the confidence of knowing tappets won't stick or bleed down once installed. This tool is available for both Twin Cam (No. 765) and Evo (No. 766) applications. The Twin-Cam model ships with everything you need, except the drill press. For standard size hydraulic Evo tappets, install the sleeve No. 766 into the tool body and you're ready to go. For more details see No.765-IS instructions.

No. 765 - For standard size Twin Cam tappets, H-D, or JIMS Powerglide, or other aftermarket equivalent.

No. 766 - Insert sleeve adapter to fit all standard size Evo tappets, H-D, or JIMS Powerglide, or other aftermarket equivalent. Order separately.

PARTS AVAILABLE SEPARATELY			
NO.	QTY.	DESCRIPTION	PART NO.
1	1	MAIN BODY	765-1
2	1	TWIN CAM ADAPTER	765-2
3	1	TUBE FITTING	765-3
4	1	TUBE FITTING	765-4
5	1	BALL VALVE	765-5
6	1	NYLON TUBE	765-6
7	1	0-100 GAUGE	765-7
8	1	PRESSURE TANK	765-8
9	1	O-RING	765-9
10	1	PUMP-UP RAM	2400-1
11	1	ALLEN LOCK SCREW	1691-29
12	1	NUT	1218
13	1	INSTRUCTION SHEET	765-IS
14	1	EVO TAPPET ADAPTER (OPTIONAL)	766



## PISTON JET TEST STAND

Ever wonder what that piston jet is doing deep inside your crankcase? If "stuck open" - possible sumping issues? If "stuck closed" - increased operating temperatures? Only with JIMS can the detail minded engine builder clear the jet of all assembly lubes, verify the PSI number the jet switches "on" and visualize the spray pattern. Better yet, do all of this before you seal the cases! You can perform the test by using regulated air over oil for real life accuracy & visual confirmation, or just air for easier clean up. If you plan to rebuild more than two Twin Cam engines and or lower ends - this tool pays for itself! For more details see No.772-IS instructions.

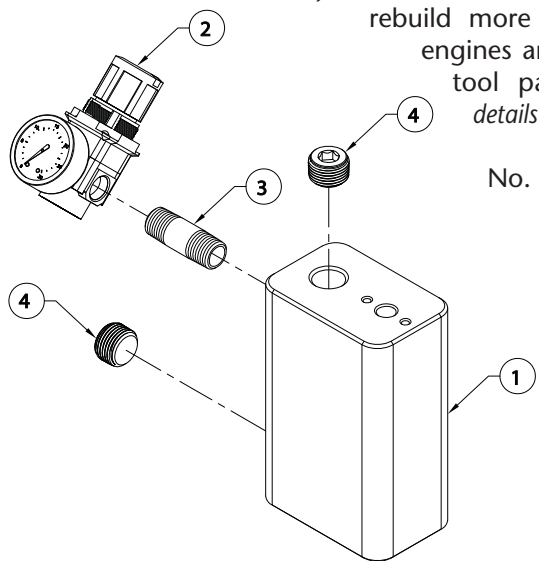

No. 772 - Piston Jet Test Stand for 1999 to present Twin Cam piston jets.



PARTS AVAILABLE SEPARATELY			
NO.	QTY.	DESCRIPTION	PART NO.
1	1	MAIN BODY	772-1
2	1	REGULATOR W/GAUGE	772-2
3	1	PIPE NIPPLE	772-3
4	2	ALLEN PLUG	772-6
5	1	INSTRUCTION SHEET	772-IS



# LIFT CADDY, SPRING TESTER



## JIMS LIFT CADDY

Introducing the patent pending "JIMS® Lift Caddy". This unique new product allows you to move your bike lift, with a bike on it, by yourself on a smooth floor. The sturdy steel design incorporates two low profile 2" wide heavy duty casters that can rotate 360 degrees, and is capable of handling today's heavy 900 lbs+ motorcycles. Even better, the Caddy is only activated when the lift is fully raised (not resting on any lock tabs). Once lowered to any lock tab, or the floor, the wheels camber up securing the lift to the floor as if the lift caddy isn't even there. In short, the lift only moves when you want it to and is secure when you are working on the motorcycle, as well as when loading and unloading. *For more details see No.776-IS instructions.*

No. 776 - "JIMS LIFT CADDY" will fit on "Handy®" lifts, "Handy's®" STANDARD No.10740,- and other lifts that incorporate a 2" wide cross member.

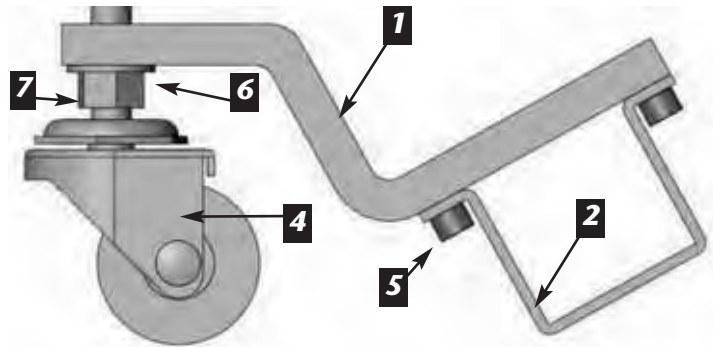
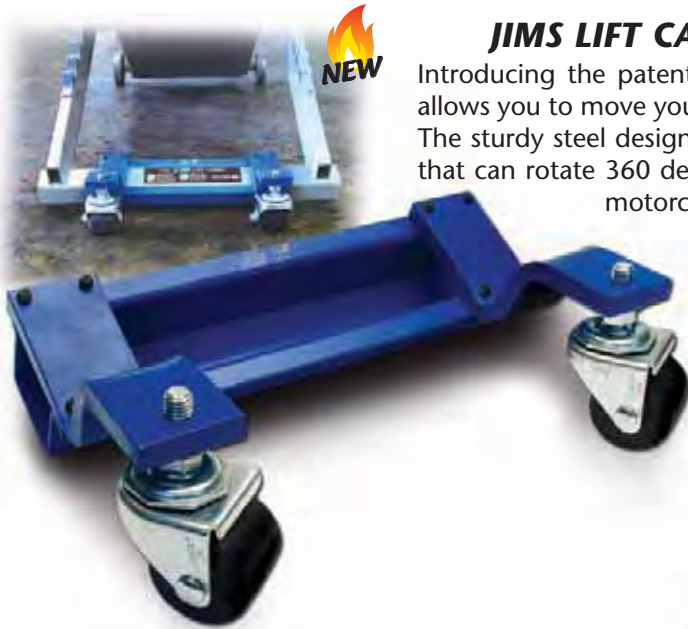

### PARTS AVAILABLE SEPARATELY

NO.	QTY.	DESCRIPTION	PART NO.
1	2	CASTER MOUNTS	776-1
2	1	FRAME MOUNT	776-2
3	1	STICKER (NOT SHOWN)	776-3
4	2	CASTER	2101
5	8	SCREW	2103
6	2	WASHER	2038
7	2	NUT	1027
8	1	INSTRUCTION SHEET	776-IS

## JIMS NEW & IMPROVED MINI VALVE SPRING TESTER 0 TO 1000 P.S.I. GAUGE

Use this tool in either a bench vice, arbor, hydraulic screw press or a drill press. Tool fits any dual rate or conical valve spring with an O.D. no larger than 1.6" diameter. Precision gauge comes with a protective rubber boot. *For more details see No.1090-IS instructions.*  
No. 1090 – Use on any dual rate or conical valve spring with a O.D. no larger than 1.6" diameter.



### PARTS AVAILABLE SEPARATELY

NO.	QTY.	DESCRIPTION	PART NO.
1	1	PISTON BODY, SPRING TESTER	1090-1
2	1	PISTON, SPRING TESTER	1090-2
3	1	PRESSURE PLATE, SPRING TESTER	1090-3
4	2	PLATE HOLDER	1090-4
5	2	1/4-20 X 3/4" FLAT HEAD SOCKET SCREW	1722
6	1	1/8" NPT PLUG	1201
7	1	QUAD SEAL	1089
8	1	GAUGE, PRESSURE, 0-1000, 1/4 NPT BOTTOM	1104
9	1	RETAINING RING	1131
10	1	COVER, GAUGE BOOT	1132
11	1	INSTRUCTION	1090-IS

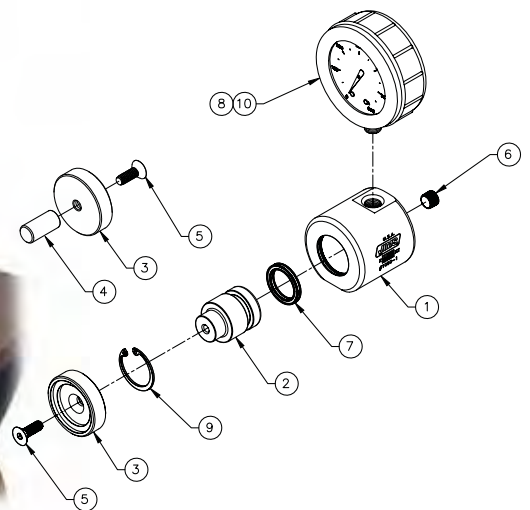

## TWIN CAM® TIMKEN® CASE BEARING CONVERSION TOOL



PATENT PENDING



4

This tool is a must for the big cubic inch late model Twin Cam® engine builder. It may also be used to replace bearing for stock 88", 96", or 103" engines. Utilizing the special JIMS® precision insert, it is designed to easily and accurately convert the left side crankshaft roller bearing (H-D® No.24604-00D) to the more durable Timken® Bearing (H-D® No.9028). This insert is manufactured from aerospace quality steel that is several times stronger than the aluminum case material the standard bearing rides in. *For more details see No. 959-IS and 2246-IS instructions.* The Tool Includes:

- A new steel bearing insert held to under .0002" total indicator reading. See No.956
- A press plate No.959-2 that will hold the bearing insert in line with the case bearing bore at the time it is being pressed into case.
- All the necessary drill bits to drill oil feed and return holes, hardware, and detailed instructions.
- This job can be performed with normal hand tools, a hand drill, and a 2 ton press.

No.959 - Use on Twin Cam® engines 2003-present. Order Timken® bearings separately. For replacement insert sleeves see No.956.



### TIMKEN® REPLACEMENT SLEEVE

This bearing insert kit is designed exclusively for use with JIMS® tool No.959 shown above and must be installed only with this tool. The insert is made from aero space quality steel and has been designed to eliminate the center ring normally used between the bearings. This kit includes: bearing sleeve, mounting hardware, Loctite, and detailed installation instructions. *For more details see No. 959-IS instructions.*

No.956 - Bearing Insert kit. Must be used with JIMS® tool No.959 on 2003 to present Twin Cam® motors.

No.956K - 6 Pack of Bearing Insert kits.

#### PARTS AVAILABLE SEPARATELY

NO.	QTY.	DESCRIPTION	PART NO.
1	1	TIMKEN® BEARING INSERT (KIT # 956)	959-1
2	1	PRESS PLATE	959-2
3	1	BOTTOM LOCATOR PLATE	959-3
4	1	BIG TWIN PRESS INSTALLER PLUG	2246-4
5	2	DRILL BIT	1721
6	1	DRILL STOP COLLAR (USE ON #1721)	1264
7	1	DRILL BIT	1713
8	1	DRILL STOP COLLAR (USE ON #1713)	1292
9	2	DRILL BIT	1714
10	1	DRILL STOP COLLAR (USE ON #1714)	1267
11	4	SCREW, 10-24 X 1-1/2 SHCS	1234
12	1	ROLL TAP	2288
13	1	BASE INSTALLER	2246-1
14	1	PROTECTIVE CASE	2165
15	1	TAP GUIDE	959-4
16	6	SCREWS, FLAT PHILLIPS	2025
17	1	#620 LOCTITE	1286-1362
18	1	SCREW, 3/8-16 X 2-1/2 SHCS	1128
19	1	TAP MAGIC	1698
20	1	INSTRUCTION SHEET	959-IS
21	1	INSTRUCTION SHEET	2246-IS

#### PARTS AVAILABLE SEPARATELY

NO.	QTY.	DESCRIPTION	PART NO.
1	1	TIMKEN® BEARING INSERT	959-1
2	6	SCREW, FLAT PHILLIPS	2025
3	1	#620 LOCTITE	1286-1362
4	1	INSTRUCTION SHEET	2246-IS



**NEW**

5



## FUEL PRESSURE TEST GAUGE TOOL

This gauge is a must have JIMS® new tool as 90% of all Big Twins motorcycles have Electronic Fuel Injection, (EFI). If you have a customer that is experiencing any of the following conditions:

- Hesitation under acceleration
- Loss of power
- Back firing through the intake
- Poor fuel economy
- Stalling out
- Engine turns over but will not start

These are just a few symptoms that improper fuel system pressure may contribute to. This fuel pressure gauge is easily installed in line with the motorcycles fuel supply system. All fuel testing should be (if possible) performed with the engine running. JIMS® supplies you with all the necessary hose connections and fittings to safely perform a fuel pressure test in about the same amount of time it takes to change a set of spark plugs. *For more details see No.955-IS instructions.*

No.955 - Use on all H-D® models using EFI, includes V-Rod.

### PARTS AVAILABLE SEPARATELY

NO.	QTY.	DESCRIPTION	PART NO.
1	1	MAIN HOSES, VALVES & GAUGE ASSY	955-23
2	2	TANK CONNECTER ADAPTER	955-24
3	1	INSTRUCTION SHEET	955-IS



**NEW**

## JIMS THREAD CHASER FOR OXYGEN SENSORS

Use to remove any I.D. thread damaged from either exhaust carbon or the mating components, both in aluminum or steel.

No. 1757- Use on all 18mm 2006 to 2009 FLH also for all 2006 to present Dyna, FXST, XL and V-Rod O2 Oxygen Sensor in exhaust systems.

No. 1758 - Use in 12mm spark plug holes from 1999 - later Twin Cam, 1986 and later XL and XR. Also Screamin' Eagle EVO heads and 2002-later VRSC, use on 2010 -later, FLH O2 Oxygen Sensor on the exhaust systems.



# OXYGEN SENSOR TOOLS



## 2012 TWIN CAM O2 SENSOR WRENCHES

JIMS has just released two new 2012 oxygen sensor wrenches. You must have these to remove or install the O2 sensors without removing the exhaust pipes on the motorcycle. For more details see No. 755-IS & 756-IS Instructions.

No. 755 - Use on 2012 Dyna and V-Rod models also for the 2012 Softail front exhaust pipe sensor.

No. 756 - Use on 2012 Softail rear exhaust pipe sensor.



5



## 14 MM OXYGEN SENSOR WRENCH TOOL

This tool is a must for removing and installing H-D's new 4 wire heated Oxygen Sensors. The new fragile O2 sensor must be torqued to 14 ft-lbs, lending to the design of this tool to be used with a 3/8" drive torque wrench. For more details see No. 784-IS Instructions.

No.784 - Use on 2010-present FLH, Touring Models



## OXYGEN SENSOR SOCKET TOOL

This tool is used to remove or install the oxygen sensor on all closed loop fuel injected H-D® models. Socket has a 3/8" drive receiver or can be used with a 7/8" wrench. Socket will withstand up to 125 ft/lbs of torque.

No.969 - Use on 2006-present XL, 2006-2011 VRSC, FXD, and FXST also 2006-2009 FLH and trike.



## JIMS COLOR VIDEO SCOPE

Introduced in 2010, the JIMS Video Scope has set the industry standard for an affordable and user friendly color video diagnostics. Inspect the rear cam shoe without removing the cam plate, get a good look at the cylinder wall liners, inspect the bottom of a sealed tank, find a lost bolt, etc... Instantly saving you hours of troubleshooting. New for this year is the "Picstik" - An easy to use storage device that allows you to directly download and save from the inspection scope. This product can be used in many fields other than motorcycles and automotive. See Picstik on the right.

No. 783 - Video Scope

No. 761 - Video Scope with PicStik



## JIMS PICSTICK

JIMS new PicStik user friendly picture and video storage device allows you to directly download and save inspections from our popular JIMS Video Scope No 783. An excellent way to document service work needed and provide important and supportive information to your customers. A must have accessory for the everyday mechanic or professional working in the motorcycle or automotive field and is designed, engineered, and manufactured in the USA..

- Cell phone size for easy carry
- Auto on with one touch recording
- Both JPEG picture and AVI video recording
- Eliminates the need to have a computer nearby
- 2 Gig storage for 100's of pics or up to 2 hrs video
- USB and RCA cords supplied
- AAA batteries included

No. 762 - JIMS PicStik

No. 761 - JIMS PicStik with Video Scope



## JIMS AUDIO ISOLATION TOOL

The JIMS® Audio Isolation Tool is designed to capture unique ranges of non-audible ultra sounds which are extremely useful in engine diagnostics. This tool uses sound frequency isolation allowing you to hear sounds at frequencies you would not normally hear so you can easily detect the problem. From mechanical to electrical noise and even air leaks, this bad boy goes way beyond a simple stethoscope or listening to the noise via a screwdriver. You will also find this device to be handy in many other industries and projects. Given that similar units often sell for \$1400, JIMS is proud to introduce this technology to you at an affordable price. Batteries also included.

No. 763 - Audio Isolation Tool



# AFR DIAGNOSTIC TOOL & AFR PROGRAM



## WEGO III WIDE – BAND AFR (AIR FUEL RATIO) MONITORING SYSTEM WITH JIMS DIAGNOSTIC SNIFFER

- JIMS version of this monitoring system comes exclusively with our Diagnostic Sniffer tool and is a complete fuel /air ratio metering system with built – in data logging. During testing the readings were virtually identical to the readings from a wideband sensor mounted in the stock location near the cylinder head. Accurate readings were obtained above approximately 10% throttle.
- Versatile tuning aid for all carbureted and fuel injected engine system displays AFR (air fuel ratio) and logs over two hours data including AFR, engine rpm and a spare 0-5V analog input for sensors such as throttle position or manifold pressure.
- Can be used for on road or dyno testing; suitable for automotive, motorcycle and other small engines.
- Highly accurate with less than + / - 0.10 AFR error over 10.3-19.5 AFR range.
- Easy free – air calibration procedure corrects for sensor aging effects.
- 0-5V analog AFR output interface for dyno instrumentation.
- Waterproof ultra – bright daylight – readable blue LED display with automatic dimming under low light conditions.
- Wide supply voltage range from 11-16V allows operation from battery on small engines and race vehicles without an alternator; current drain is approximately 1 amp.
- Compact size: 4" L x 2" W x .5" H.
- Wego III data logging software runs under Windows ME/XP/VISTA. The software allows AFR, engine rpm and analog sensor data with user defined scaling. Data can also be exported to Excel for further analysis.
- Sold in a system that includes Wego III Wide - Band Exhaust Gas O2 Sensor Interface, 42" harness, Bosch LSU 4.2 five wire wide band O2 sensor.
- Built-in USB interface and Software on CD ROM.

### PARTS AVAILABLE SEPARATELY

NO.	QTY.	DESCRIPTION	PART NO.
1	1	MANIFOLD	777-1
2	1	MOUNTING PLATE	777-2
3	1	COILED OUTLET TUBE	777-3
4	1	SAMPLER TUBE	777-4
5	1	CLAMP, WORM DRIVE	777-5
6	2	COMPRESSION FITTING	777-6
7	1	EXHAUST WRAP	777-7
8	1	PIERCING TEST CLIPS	777-8
9	1	ALLIGATOR CLIPS, PAIR	777-9
10	1	BANANA JACK, BLACK	777-10
11	1	BANANA JACK, RED	777-11
12	3	SCREW	1220
13	1	INSTRUCTION SHEET	777-IS

**Note: For any technical support on the modules contact: Daytona Twin Tech 1-386-304-0700.**

No. 773 - Use on any motorcycle that does not use a catalytic converter.

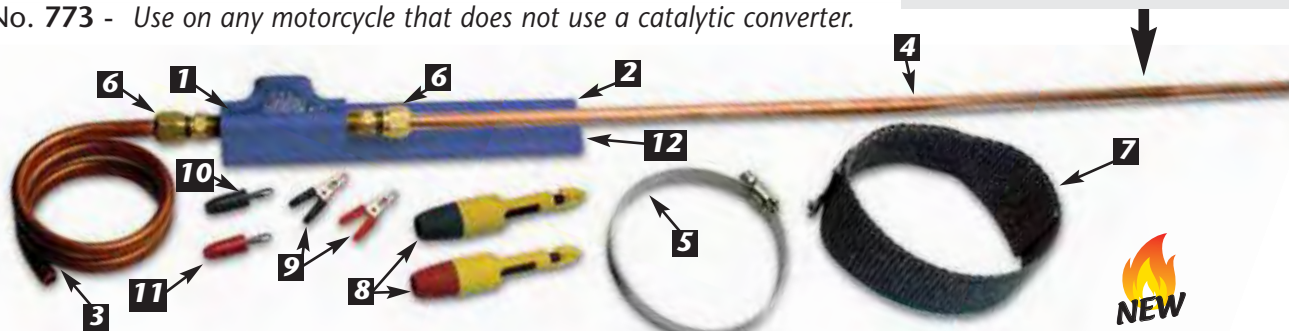

## JIMS AFR DIAGNOSTIC SNIFFER (AIR FUEL RATIO)

This new JIMS tool is to be used with the Daytona Twin Tec (WEGO) or an equivalent AFR Monitoring System. JIMS has manufactured and assembled all the parts needed for a single part number, user friendly AFR diagnostic sniffer tool kit. Simply install the WEGO III sensor cable into the new JIMS manifold sniffer. The JIMS AFR diagnostic sniffer comes complete with heat wrap, wire taps, and clamp for securing the sniffer to the exhaust system. When combined with the Daytona Twin Tec Monitoring system you can easily record, without a Dyno, critical and accurate AFR readings for proper tuning and diagnostics. For more details see No.777-IS instructions.

No. 777 – Sniffer alone (To be used with Daytona Twin Tec existing AFR Monitoring System)



6



## COMPRESSION TESTER

This quality American made tester is designed to test cylinder compression. Gage comes with protective rubber cover. Hoses fit into spark plug holes of all current Harley models which includes sizes 12mm, 14mm, and 18mm for Big Twins and Sportsters. For more details see No.953-IS instructions.

No.953 - Fits all H-D® models and aftermarket twins.



## BETA ENGINE INTERCONNECT SEAL LEAK TESTING TOOL

Yet another tool to properly inspect your lower end assembly before sealing the cases. This new tool will check the sealing of the interconnect seal H-D No.45359-00. Use the tool along with a JIMS No.782 Leakdown Tester. This test assures you there is no leakage in the seal that can cause over oiling of the lower end. For more details see No.780-IS instructions.

No. 780 - Use on all Beta Twin Cam engines 2000 to present.



## HOSE REPAIR KIT 1/4" – 5/16"

Hose barbed end is .3125 (5/16"), threaded end is 12mm. It can be used with either a .250" or .3125" hose. Works well to repair JIMS® tool No.1087 Leakdown Tester, or the 12mm spark plug threads found on all Twin Cams, or XL 1986 and later as well as Screamin' Eagle EVO BT heads. For more details see No.1087-IS instructions.

No.1087-2



## DUAL GAUGE LEAKDOWN TESTER

Includes a 12mm and a 10mm adapter. Gages comes with protective rubber cover. The hose assembly has both 14mm and 18mm spark plug threads. The tool is easy to use and will troubleshoot cylinder leakdown issues such as valve seat issues, bad rings, bad head gasket, etc. For more details see No.782-IS instructions.

No. 782 - Use on all models.

(NOTE: Includes Twin Cam and aftermarket motors)

## MASTERMIND DIAGNOSTIC SCANTOOL FOR USE ON HARLEY DAVIDSON®



This diagnostic Scantool from BDM retrieves trouble codes and displays an array of sensor levels for ECM controlled fuel injected and carbureted Big Twins. In conjunction with your Harley Davidson® service manual, this tool can quickly and accurately diagnose many common and complex problems. This Scantool has multi-functions that allow you to monitor your system's status in areas such as; injector cycles, ignition spark, RPM, and much more. The main unit is protected by a rubberized jacket that is both durable, and easy to hold. The large LCD screen is easy to read and is backlit for low lit situations. The software is delivered via an upgradeable cartridge specifically designed for use on Harley Davidsons®, and all harnesses and adapters are included as well a comprehensive instruction manual. If you are at all leery of purchasing a new product with this level of sophistication, consider that this exact platform has been used in the automotive industry for many years, and it's been bullet proof!

No.1149 - Use on Delphi fuel injection models 2001-05, except V-Rod. This BDM Kit includes a Delphi software cartridge.

No.1249 - Use on Delphi fuel injection models 2001-05, except V-Rod. Delphi software cartridge only.

No.1159 - Use on Magnetti Marelli fuel injected models 1995-01 and all carbureted Twin Cam® models 1999-03. This software cartridge only can be used with the No.1149 BDM Kit.



**EASY TO READ MENUS**

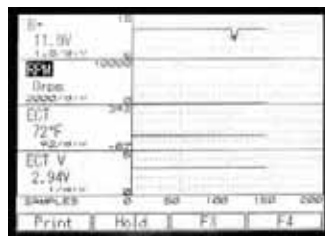

**DYNAMIC REAL TIME CHARTS**

Parameter	Value
Battery Positive Voltage	11.9V
Engine Temperature	72°F
ECT V	2.94V
Idle Speed Control Pos.	1380BPS
Injector Pulse Width	0.06S
Intake Air Temperature	DEFAULT

**INSTANT DATA REPORTS!**

### BDM KIT INCLUDES

- 1 Bi-Directional Scantool
- 2 Custom Carrying Case
- 3 8ft Main Diagnostic Cable
- 4 Harley® Adapter Harness
- 5 Harley Software Cartridge
- 6 BDM Operations Manual
- 7 12V Power Supply
- 8 4 AA Batteries

**UPGRADEABLE SOFTWARE CARTRIDGE!**





7



## **IGNITION SWITCH CONNECTOR REMOVER TOOL**

Use this tool to safely remove the ignition switch wiring connector. Slip the dog bone end of tool into the bottom side of connector until it is touching the back end of connector box. Then gently pull out the male wiring connector and tool. *For more details see No. 942-IS instructions.*

**No.942** - Use on all FL Touring models 2003 to present that have a H-D No.61530-03B.



## **IGNITION SWITCH HOUSING ALIGNMENT TOOL**

This tool will easily align the ignition switch housing as the retaining screws are being torqued. This gives the ignition switch knob the alignment it needs to help extend the life of the ignition switch housing. *For more details see No. 943-IS instructions.*

**No.943** - Use on all FL Touring models 2003 to present that have a H-D No.61530-03B.



**Chicago Joe (Nitro blast)**





## **FUEL PUMP RETAINER REMOVER / INSTALLER TOOL**

This is a must use tool for removal or installation of retaining ring otherwise you run the risk of developing a fuel leak. Tool safely removes the retaining ring holding the fuel pump. Use for quick and easy service of fuel filter and other fuel related parts. Hold ring remover tool and a 1/2" ratchet with both hands when working near or around the fuel tank, then remove and install retaining ring. Cover all painted surfaces to help guard against damage. For more details see No. 954-IS instructions.

No.954 - Use on all FL models, with new fuel tank, 2008 and later.



**NEW**

## **DYNA IGNITION SWITCH / FORK LOCK REMOVER / INSTALLER TOOL**

This tool is used to make removing/installing the Dyna ignition switch/ fork lock simple. This tool locates on the ignition switch face nut that holds the switch in place on the frame, letting you remove or install this switch correctly. Tool has a 3/8" drive access hole. For more details see No. 778-IS instructions.

No. 778 - Use on 2006 to present Dyna models.



**Kirby Apathy**



## WIRE PIERCING TOOL KIT

This tool is used when you're looking for an easy way to pierce into positive or negative power sources in a wire harness. Fits wires from .030" through .180" diameter insulation. Do not use on voltages larger than 30VAC or 60VDC. Maximum current 5 A. Tool comes with banana jacks on tool. Included are a red & black banana post connectors.

No. 758 - Use on any wire from .030" through .180" diameter insulation.



7



## JIMS 12MM X 1.25 THREAD CHASER FOR SPARK PLUG AND OXYGEN SENSORS

Use to remove any I.D. thread damage that may have come from either exhaust carbon or the mating components, both in aluminum or steel.

No. 1758 - Use in spark plug holes from 1999 - later Twin Cam, 1986 and later XL and XR. Also Screamin' Eagle EVO heads and 2002-later VRSC, use on 2010 -later, FLH O2 Oxygen Sensor on the exhaust systems.



## RECEPTACLE & PIN EXTRACTOR

Easily removes the molex style pin from connectors. For

more details see No.2121-IS instructions.

No.2121A - Pin Extractor- Use on all models.

No.2122A - Receptacle Extractor- Use on all models.



## 18MM O2 SENSOR THREAD CHASER

No. 1757- Use on all 2006 to 2009 FLH also for all 2006 to present Dyna, FXST, XL and V-Rod O2 Oxygen Sensor in exhaust systems.

## 6-IN-1 STAR RECEPTACLE EXTRACTORS

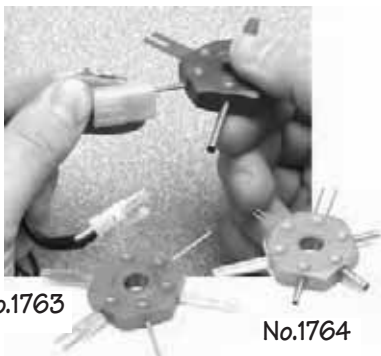

Easily remove an assortment of harness style receptacle pins with either of these 6-in-1 tools. Designed for automobiles, we have found these to work equally well on Harley-Davidsons®.

No.1763 - Use on ALDL, Pack-Con, and weather connectors.

No.1764 - Use on most compression tong style connectors.



## 14MM & 18MM SPARK PLUG HOLE THREAD CHASER

This double-ended, 14mm and 18mm thread chaser easily cleans-up spark plug holes, reducing the chance of cross threading. Use with 13/16" socket.

No.1770 - Use on all 14mm and 18mm spark plug holes.



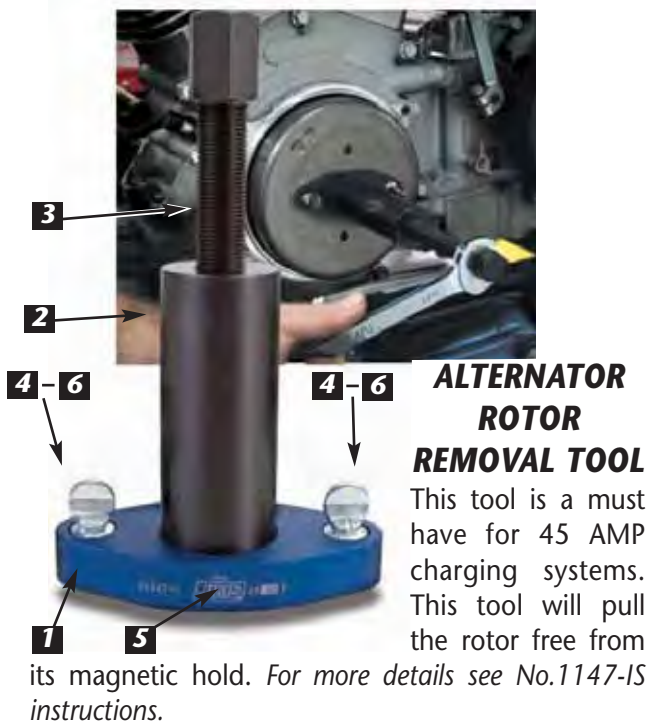

## ALTERNATOR ROTOR REMOVAL TOOL

This tool is a must have for 45 AMP charging systems. This tool will pull the rotor free from its magnetic hold. For more details see No.1147-IS instructions.

No.1147 - Use on FL and Ultra models, 1997-06.

### PARTS AVAILABLE SEPARATELY

NO.	QTY.	DESCRIPTION	PART NO.
1	1	PULLER BASE	1147-1
2	1	TUBE	1047-2
3	1	SCREW	1024
4	4	THUMB SCREW	1199
5	1	TUBE, O-RING (NOT SHOWN)	1198
6	2	THUMB SCREW, O-RING (NOT SHOWN)	1197
7	1	INSTRUCTION SHEET	1147-IS



Anders Lundgren



## REMOTE START BUTTON

This simple remote switch makes it easy to activate the starter & rotate the engine without starting. Comes in handy for tappet adjustments, servicing and diagnosing starting & electrical issues. Tool provided with four foot lengths well insulated lead cables with an alligator clips for positive and one for negative post hookups. For more details see No.752-IS instructions.

No. 752 - Use on all motorcycles with access to starter positive post terminal and motor post negative terminal.



## NEW INLINE SPARK TESTER

This tool is designed to give you quick easy visual check of the ignition system. Quickly diagnose a ignition system with this in line tester. Works on all ignition systems including distributorless ignition.

No. 750 - Use this inline tester on all models.  
No. 751 - Replacement bulb for above No.750.



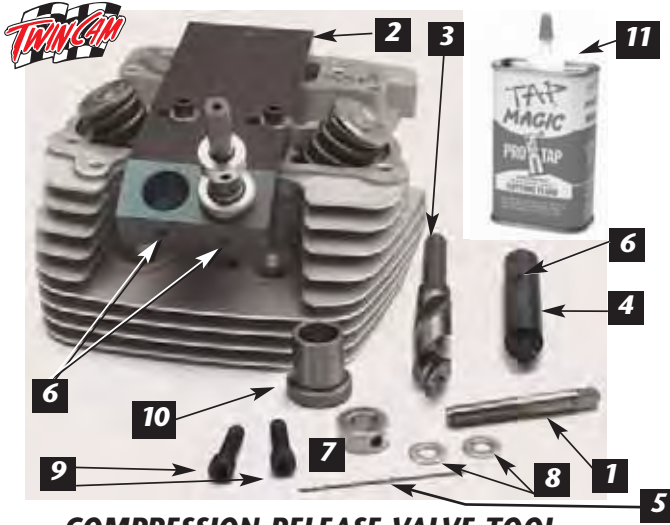

## COMPRESSION RELEASE VALVE TOOL GUIDE FIXTURE FOR DRILLING COMPRESSION RELEASE

Use this tool for machining all Twin Cam® heads 1999 and later to install JIMS® No.727K compression release valves. Install on the front or rear head with or without the valves installed. Simply drill, spot face, tap and install compression release valves No.727K. *For more details see No. 1169-IS instructions.*

No.1169 - Use on all Twin Cam® "A" or "B" models.

### PARTS AVAILABLE SEPARATELY

NO.	QTY.	DESCRIPTION	PART NO.
1	1	THREAD TAP TOOL	1169-1
2	1	DRILL/TAP FIXTURE	1169-2
3	1	STEPPED DRILL	1169-3
4	1	TAP EXTENSION	1169-4
5	1	DRILL BIT	2224
6	3	SET SCREW	2221
7	1	STOP COLLAR	2227
8	2	FLAT WASHER	2014
9	2	MOUNTING SCREW	2016
10	1	DRILL BUSHING	2219
11	1	TAP MAGIC	1698
12	1	INSTRUCTION SHEET	1169-IS



## COMPRESSION RELEASE THREAD TAP TOOL

For cutting threads in the cylinder head to install JIMS® compression release valves. Tap Size: M10 x 1.0. Use with 9mm (.354") pilot.

No.1169-1 - Use on all Big Twins and XL engines.



## ADAPTERS FOR 7MM VALVE GUIDES

The JIMS head holder tool makes pressing valve guides in and out simple. These adapters are required to update JIMS earlier tool No.2240 shown below for 7mm Valve Guides. *For more details see No. 2240-IS instructions.*

2240-19 - 7mm Assembly Pilot

2240-11-4 - 7mm Insert

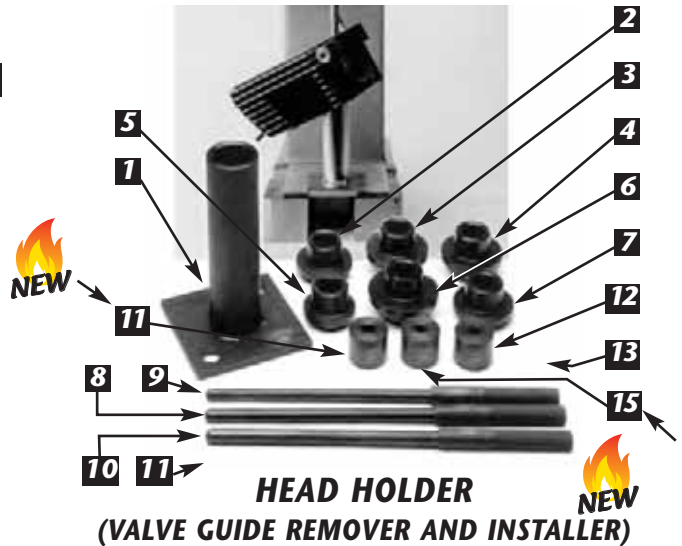

Comes with adapters to fit all H-D® and aftermarket heads. Adapters are supported by a support stand. Makes pressing valve guides in and out simple. A special guide alignment shaft is designed into this tool. This shaft holds the right angle for the best possible guide installations. Save time and money by installing the guides, in line, with the valve seats, time and time again - for much less seat grinding. *For more details see No. 2240-IS instructions.*

No.2240 - See Applications Below.

### PARTS AVAILABLE SEPARATELY

NO.	QTY.	DESCRIPTION	PART NO.
1	1	BASE ASSEMBLY	2240-1
2	1	ADAPTER, INT, 1986-03 883 XL, ALL T/C EXH	2240-2
3	1	ADAPTER, INT, B/T, EVO, 1986 XL1 100 EXH. SHOVELHEAD AND 1986-03 883 EVO XL	2240-3
4	1	ADAPTER, INT, SHOVEL HEAD / EXH BIG TWIN, EVO, 1986 1100, XL, MOST ALL T/C	2240-4
5	1	ADAPTER, INT / EXH, IRONHEAD XL	2240-5
6	1	ADAPTER, INT, 1987-1100 / 1988-03 1200 XL, EVO	2240-6
7	1	ADAPTER, EXH, 1987-1100 / 1988-03 1200 XL, EVO	2240-7
8	1	PILOT, .306 DIAMETER	2240-16
9	1	PILOT, .371 DIAMETER	2240-17
10	1	PILOT, .338 DIAMETER	2240-18
11	1	PILOT 7MM DIAMETER	2240-19
12	1	INSERT, .310 DIAMETER	2240-11-1
13	1	INSERT, .375 DIAMETER	2240-11-2
14	1	INSERT, .342 DIAMETER	2240-11-3
15	1	INSERT, 7MM DIAMETER	2240-11-4
16	1	INSTRUCTIONS	2240-IS

# VALVE TRAIN TOOLS



## JIMS NEW & IMPROVED MINI VALVE SPRING TESTER

### 0 to 1000 P.S.I. GAUGE

Use this tool in either a bench vice, arbor, hydraulic screw press or a drill press. Tool fits any dual rate or conical valve spring with an O.D. no larger than 1.6" diameter. Precision gauge comes with a protective rubber boot. *For more details see No.1090-IS instructions.*

No. 1090 – Use on any dual rate or conical valve spring with an O.D. no larger than 1.6" diameter.



## CONICAL VALVE SPRING COLLAR

Add this collar to your JIMS® valve spring compressor tool No.96600-36B on right to remove and re-place valves and conical valve springs (Bee Hive) H-D® No.18245-02 or H-D® No.18245-02.

A must-have tool for safe valve work. *For more details see No. 96600-IS instructions.*

No.988 - Use on all 2005-present Big Twins, except S.E. models. Use on all 2004-present XL's. Use on all 2003-present Buell® Twins, except 1125R.

See page 40 for JIMS® Beehive Springs.



## HEAD HOLDER TOOL

Use to hold head in vice through spark plug hole. Has 14mm and 12mm ends. This tool allows you to easily position head for all types of work. *For more details see No. 2341-IS instructions.*

No.2341 - Use on Big Twin 1948-present. (Includes Twin Cam® aftermarket heads.) Use on Sportster® 1957-present. Use on Buell® 1987-present, except 1125R.



**NEW**

## PUSHROD COVER CLIP INSTALL AND REMOVAL TOOL

First thought... why would I need this tool when I've been installing and removing pushrod covers for years

with just a screw driver? Made from black delrin, this tool will NOT marr or slip – and will install the clip professionally, with just one hand, in seconds! It's a luxury tool that you will appreciate for years to come. *For more details see No.917-IS instructions.*

No. 917 - Use on all V-Twins that use pushrod clips.

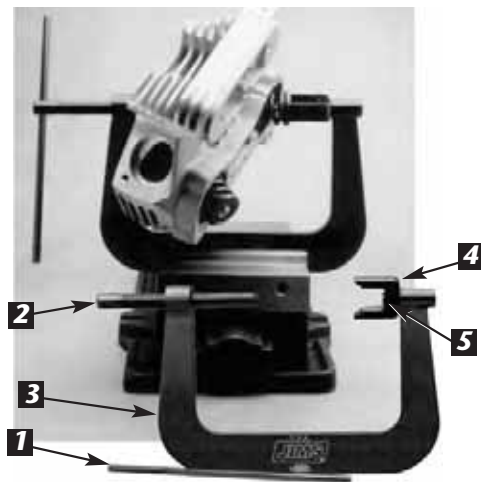

## VALVE SPRING COMPRESSOR TOOL

This tool is necessary for removing or installing valves. Hardened ball bearing style tip at valve head end eliminates damage to valve. Comes with new valve collar receiver for safer tool usage, and can be clamped in vice. *For more details see No. 96600-IS instructions.*

No.96600-36B - Use on all OHV Big Twins and XL's to 2003. Use on all Buells® to 2002. Use on all Big Twin S.E. Models to present.

**NOTE:** For Beehive Springs, order No.988 Collar (shown above).

### PARTS AVAILABLE SEPARATELY

NO.	QTY.	DESCRIPTION	PART NO.
1	1	5/16" HANDLE	96600-36B-4
2	1	5/8" SCREW	96600-36B-3
3	1	MAIN BODY	96600-36B-7
4	1	COLLAR	96600-36B-9
5	1	SNAP RING	2145
6	1	INSTRUCTION SHEET	96600-IS

# VALVE TRAIN TOOLS



## SHOULDERLESS VALVE GUIDE INSTALLER TOOLS

These valve guide installer tools will install each guide to the correct depth when installed into head. Remover handles are used as handle for installer tools. Must be ordered separately. Refer to chart for correct handle usage. Use tool No.1001 or No. 2240 for removing or installing shoulder type valve guides.

FOR MORE DETAILS SEE INSTRUCTION SHEET NO.

PART NO.	APPLICATION	USE WITH HANDLE NO.	FOR MORE DETAILS SEE INSTRUCTION SHEET NO.
No.938	Use on all T/C 2005 and later that use the 7mm valve guides. Use on 2004 and later Sportster®. Use on 2004 Buell® Twins to present, except 1125R.	No.937	No.938-IS
No.949	Use on H-D® 110" CVO motorcycles 2007 to present.	No.937	No.949-IS
No.34731-84	Use on all Big Twin motors with about .560" Dia.. O.D., Includes aftermarket heads.	No.34740-84	No.34731-IS

8

## SHOULDERLESS VALVE GUIDE REMOVER TOOLS

Use to remove shoulderless valve guides including the newest 7mm size guides. On the 7mm guides there is no need to remove carbon off the guide because you remove from the spring side of head. Use chart to reference installer part No. Order separately.

FOR MORE DETAILS SEE INSTRUCTION SHEET NO.

PART NO.	APPLICATION	USE ON INSTALLER TOOL NO.	FOR MORE DETAILS SEE INSTRUCTION SHEET NO.
No.937	Use on all T/C 05' and later that use the 7mm valve guides. Use on 04' and later XL Use on 04' Buell® Twins to present, except 1125R.	No.938	No.937-IS
No.34740-84	Use on all Big Twin motors and Twin Cam® to 2004. <b>NOTE:</b> Includes all aftermarket heads.	No.34731-84 No.34643-84 No.948 & No.949	No.34740-IS

## SHOULDERED VALVE GUIDE DRIVER SET



Use for guide removal and installation on all models. Manufactured from 1144 stress proof steel. For more details see No.1001-IS instructions. **Sold as 3 piece set.**

No.1001 - Use on all models.

## PARTS AVAILABLE SEPARATELY

NO.	QTY.	DESCRIPTION	PART NO.
1	1	DRIVER /BLACK .370" (3/8")	1001-1
2	1	DRIVER /BRIGHT ZINC .338" (11/32")	1001-2
3	1	DRIVER /GOLD .307" (5/16")	1001-3
4	1	INSTRUCTION SHEET	1001-IS



## VALVE GUIDE SEAL INSTALLER TOOLS

These valve guide seal installer tools will install each guide seal evenly and square on the top of each guide. Factory driver spacer not required with JIMS tool. Order handle separately for use on seal installer tools. Refer to chart for correct handle usage.

FOR MORE DETAILS SEE INSTRUCTION SHEET NO.

PART NO.	APPLICATION	USE WITH HANDLE NO.	FOR MORE DETAILS SEE INSTRUCTION SHEET NO.
No.948	Use on 110" valve guides requiring H-D® seal No.18046-98	No.34740-84	No.948-IS
No.34643-84	Use on all Big Twin models 1984-2004 with .560" Dia. Guides. Includes aftermarket heads.	No.34740-84	No.34643-IS



# VALVE GUIDE REAMERS & CASE SAVER TAPPET REAMER

**NEW**

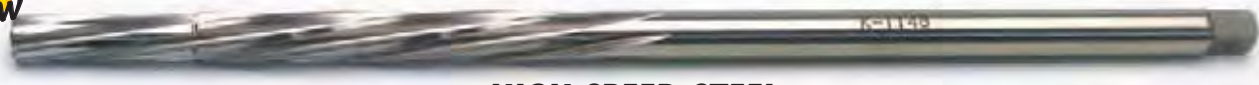

**HIGH SPEED STEEL**



**SOLID CARBIDE**

**NEW**

PART NO.	DIAMETER	DESCRIPTION	APPLICATIONS
No.1133	7mm	High Speed Steel	Twin Cam 2005 to present (except CVO T/C) Buell, Sportster 2004 to present.
No.1150	.3110"	Solid Carbide Reamer	Evo/ T/C /Sportster/Buell.
No.1151	.3115"	Solid Carbide Reamer	Evo/ T/C /Sportster/Buell.
No.1152	.3120"	Solid Carbide Reamer*	T/C 1999 to 2004 w/5/16" valve stems EVO BT and XL, 1984 to 1999.
No.1153	.3410"	Solid Carbide Reamer	Evo/ T/C /Sportster/Buell.
No.1154	.3772"	Solid Carbide Reamer	Pan/Shovel.
No.1155	.3777"	Solid Carbide Reamer	Pan/Shovel.
No.1156	.3782"	Solid Carbide Reamer	Pan/Shovel w/ JIMS Valves.

**8**

## -sizing the guide, the JIMS® way!



**FIG. 1**

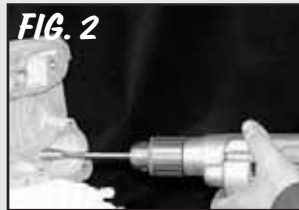

**FIG. 2**

**NEW**

### HIGH SPEED STEEL & SOLID CARBIDE VALVE GUIDE REAMERS

These unique reamers feature a 2" long pilot for perfect alignment with the valve guide while reaming. With these reamers you can expect to ream a valve guide to exact dimensions without any taper in just a few seconds.

#### JIMS® MANGANESE-BRONZE VALVE GUIDE REAMING INSTRUCTIONS

- Install the cylinder head in a vise. Protect the cylinder head with a clean towel or rag, as pictured.
- Insert the reamer pilot in the guide and lubricate with a good quality cutting oil like K-Line Bronze Reamer Lube. (Fig.1)
- Ream at 100-200 RPM with a slow feed rate. Let the reamer do the work and do not force the reamer. (Fig.2)
- After reaming all the way through, pull the reamer out with-out stopping the rotation. (DO NOT reverse rotation!)
- Clean the chips off the reamer and you're ready for the next valve guide.



**NEW**

### TWIN CAM CASE SAVER OVERSIZE TAPPET REAMER

This tool can be a case saver if you have worn out or damaged tappet bores on any Twin Cam engine case. This reamer tool is designed to ream the case to a perfect finish hone on each tappet hole, to fit a JIMS 1811. For more details see No. 789-IS instructions. No. 789 - Use on any Twin Cam engine, OEM, or aftermarket.

**NEW**

### TAPPET POWERGLIDE™II "PRESSURIZED OILING"

+ .010 Oversize Twin Cam Powerglide II Tappet. No.1811 - Use on all Twin Cam 1999 to present.





## ROCKER BOX COVER RATCHETING BOLT WRENCH

This reversible ratcheting box wrench is used on all Evolution Big twin and Sportster models to remove those hard to get at valve cover mounting bolts. This wrench is 9-3/4" long with a ergonomic rubber grip that keeps from scratching the chrome or paint. Comes with a replaceable 1/4" drive 3/16" Allen bit. This tool has a low, thin, profile and allows clearance between the frame and engine. See below for replacement bits

No. 770- Use on all Evolution Big Twin Evolution Big twin 1984 to 1999 Use on all Evolution Sportster models 1984 to present.

No. 771- Replacement 3/16" Bits for JIMS tool No. 770 above. Sold in 3-packs.

8



## VALVE GUIDE PUSHER SET

This kit lets you push the valve guide into H-D® and aftermarket heads rather than drive it in with a hammer.

No.1058 - Use on 5/16" I.D. guides.

No.1054 - Use on 3/8" I.D. guides.



## VALVE SEAT LAPPER TOOL

Use this tool to perform the final profile lapping of the valve seat. The suction cups affix to either dished or flat, and small or large valve faces. The handle is comfortably shaped, and ideal for quick and smooth rotations.

No.1774 - Use on all cylinder head valve types.



## MANLEY VALVE SPRING SEAT CUTTER

This tool is for cutting the cylinder head lower valve spring seat area for high lift cams with .500" to .650" lift. Cuts 1.630" O.D. and .760" I.D. Includes a 3/8" diameter pilot.

No.1250 - Use on 74" and 80" Big Twins.

## MANLEY VALVE GUIDE SEAL CUTTER

These tools are used for cutting valve guides while installed in the cylinder head to convert them to accept valve guide seals.

No.1251 - Cuts a .530" diameter. Supplied with a 3/8" diameter pilot.

No.1252 - Cuts a .562" diameter. Supplied with a 3/8" diameter pilot.

No.1253 - Cuts a .625" diameter. Supplied with a 3/8" diameter pilot.



## CUTTER PILOT

No.1254 - 5/16" diameter pilot for any of the spring seat or valve guide seal cutters shown above.



Endorsed By



## HEAD BOLT TORQUE GAUGE

This accurate gauge allows the measuring of 90° when tightening Twin Cam® or Evo head bolts. Torque sequence lasered on gauge, with instructions.

No.2392 - Use on all Twin Cam®, EVO, and Sportster® models 1984-present.

# VALVE TRAIN TOOLS

**NEW**



## ANGLED FEELER GAUGE

This new innovative feeler gauge holder eliminates the need to use bulky multi feeler gauge tools while performing valve adjustments. This tool is ideal for reaching down into small tight areas and incorporates an angle to help reach around corners, often necessary for adjusting valves. Tool includes two handles with: .002", .003", .004", .005", .006" and .008" inserts and an allen wrench. *For more details see No.908-IS instructions.*

No. 908 - Feeler Gauge Kit

### PARTS AVAILABLE SEPARATELY

NO.	QTY.	DESCRIPTION	PART NO.
1	2	HOLDER, FEELER GAUGE	908-1
2	2	6-32 X 3/8 BUTTON HEAD, SOCKET	1247
3	1	.002"=.05MM, BLADE, FEELER GAUGE	908-02
4	1	.003"=.08MM, BLADE, FEELER GAUGE	908-03
5	1	.004"=.10MM, BLADE, FEELER GAUGE	908-04
6	1	.005"=.13MM, BLADE, FEELER GAUGE	908-05
7	1	.006"=.15MM, BLADE, FEELER GAUGE	908-06
8	1	.008"=.20MM, BLADE, FEELER GAUGE	908-08
9	1	.009"=.229MM, BLADE, FEELER GAUGE	908-09
10	1	.010"=.254MM, BLADE, FEELER GAUGE	908-10
11	1	.011"=.279MM, BLADE, FEELER GAUGE	908-11
12	1	1" KEY RING (NOT SHOWN)	2213
13	1	908-IS INSTRUCTION SHEET	908-IS

Endorsed By



## EXHAUST STUD DRILL PLATE

This tool is designed to guide and keep alignment of drill bit in order to completely drill out broken exhaust stud. A follow up with a tap is all that is needed to clean up threaded hole. This tool can be used with motor in most frames. *For more details see No.1705-IS instructions.*

*For more details see No.1705-IS instructions.*

No.1705 - Use on all Big Twin 1984-present.

(Includes Twin Cam® and aftermarket heads.)

Use on Sportster® 1986-present.

Use on Buell® 1987-present, except 1125R.

### PARTS AVAILABLE SEPARATELY

NO.	QTY.	DESCRIPTION	PART NO.
1	1	DRILLING PLATE	1705-1
2	1	DRILL BUSHING	1705-2
3	1	1/4" DRILL	1705-3

**NEW**

## EXHAUST GASKET (SEAL) INSTALLER TOOL



No longer do you need to fight to install this fragile exhaust seal. You'll never worry about an exhaust leak again. Tool can

be used with exhaust flange nuts, or JIMS® handle, No.33416-80, sold separately. Either one will position the seal evenly into the exhaust port of head.

*For more details see No.788-IS instructions.*

No. 788 - Use on all 1984 to present EVO Big Twins, XL, and all Twin Cam models.



See list → No.1055 ← See list

## VALVE GUIDE GO-NO-GO GAUGE

This tool is an easy way to check valve-to-valve guide clearance by inserting the gauge into the valve guide bore where it will either go, or not go. Purchase all the gauge pins to quickly narrow down guide sizing.

Gauges sold separately from holder.

No.1055 - Holder Only.

### PINS AVAILABLE SEPARATELY

QTY	DESCRIPTION	PART NO.	QTY	DESCRIPTION	PART NO.
1	PIN 0.3105"	2149	1	PIN 0.3415"	2155
1	PIN 0.3110"	2150	1	PIN 0.3770"	2156
1	PIN 0.3115"	2151	1	PIN 0.3775"	2157
1	PIN 0.3120"	2152	1	PIN 0.3780"	2158
1	PIN 0.3405"	2153	1	PIN 0.3785"	2159
1	PIN 0.3410"	2154	1	PIN 0.3790"	2160

8





## ROCKER BUSHING & ROLLER BEARING PULLER

Use to remove rocker bushing or bearing in one easy operation. For more details see No.2307-IS instructions.

No.95760-57 - Use on all Big Twin 1966-present, and Twin Cam®. (**NOTE:** Includes all aftermarket rocker arms.)

Use on Sportster® 1957-present. Use on Buell® 1987-present.

### PARTS AVAILABLE SEPARATELY

NO.	QTY.	DESCRIPTION	PART NO.
1	1	PIN	2142
2	1	NUT	2128
3	1	BRASS WASHER	2129
4	1	BODY	95760-57-4
5	1	PULLER	95760-57-5
6	1	INSTRUCTION SHEET	2307-IS

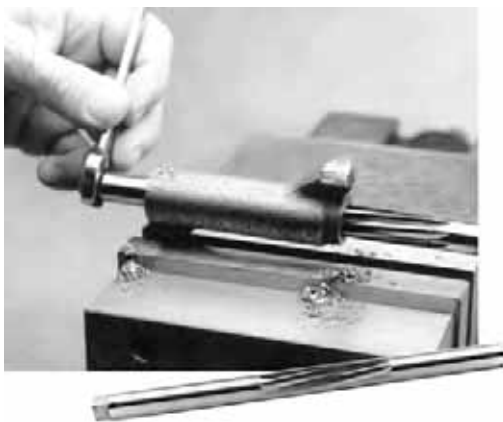

## ROCKER BUSHING LINE REAMER

Use to ream rocker bushings to a factory fit of .0007"-.0012" in line with each other. This precise line reamer is capable of a 24 finish or better. For more details see No.94804-IS instructions.

No.94804-57 - Use on all Big Twin 1966-present, and Twin Cam®. (**NOTE:** Includes all aftermarket rocker arms.)

Use on Sportster® 1957-present. Use on Buell® 1987-present.

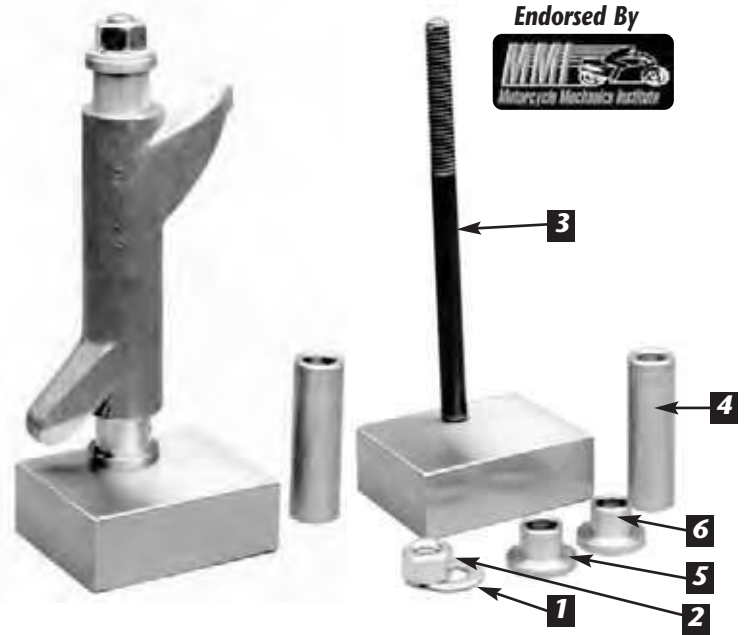

## ROCKER ARM BUSHING INSTALLER

Rocker rebuilding in half the time. Use to install rocker arm bushings in rocker arms with or without a press. This tool will install each bushing to the correct depth for the best oil control. See JIMS® rocker bushings and rocker arm hardware on page 34. Use JIMS® tool No.95760-57 for removing bushings, and ream to size with JIMS® tool No.94804-57 reamer. For more details see No.2357-IS instructions.

No.2357 - Use on all Big Twin 1966-present, and Twin Cam. (**NOTE:** Includes all aftermarket rocker arms.)

Use on Sportster® 1957-present.

Use on Buell® 1987-present.

JIMS® Roller Rockers come with bushings already installed and fit to factory size.

### PARTS AVAILABLE SEPARATELY

NO.	QTY.	DESCRIPTION	PART NO.
1	1	FLAT WASHER	2031
2	1	NUT	2035
3	1	STUD	2360
4	1	TUBE, PRESS, BUSHING	2357-3
5	1	PILOT, PRESS, BUSHING	2357-2
6	1	BASE, PRESS, BUSHING	2357-1
7	1	INSTRUCTION SHEET	2357-IS

# CAM BEARING PULLER TOOLS



**PARTS LIST REFERENCE FOR ALL REMOVERS**



**No.95760-TB**



**No.993 OR No.1279**

## INNER CAM BEARING REMOVER TOOL

Designed like our popular EVO cam bearing tool, it removes the bearing easily without any damage to the crankcase. This precision built tool will also keep the pin rollers from accidentally falling into the crankcase. Install a new JIMS No.9198K performance bearing using JIMS tool No. 787 on this application. *For more details see No.1279-IS instructions.*

**No.1279** - Use on all Twin Cam®, 2000-06 FXST, 1999-05 FXD, and 1999-06 FL's.

### PARTS AVAILABLE SEPARATELY

NO.	QTY.	DESCRIPTION	PART NO.
1	1	PULLER	1279-1
2	1	REMOVER BODY	1279-2
3	1	DOWEL PIN	95760-TB-1
4	1	3/4" BRASS WASHER	1099
5	1	3/4" NUT	1098
6	1	INSTRUCTION SHEET	1279-IS

## BIG TWIN CAM® BEARING REMOVER

Use to remove inner cam bearing without splitting cases. Easily pulls bearing from case, also keeps rollers from coming out during removal. Install a new JIMS No.9058 performance bearing using JIMS tool No. 2188 or No. 97272-60 on this application. *For more details see No.2309-IS instructions.*

**No.95760-TB** - Use on all Big Twin 1958-present single cam only. (**NOTE:** Includes aftermarket motors.)

### PARTS AVAILABLE SEPARATELY

NO.	QTY.	DESCRIPTION	PART NO.
1	1	PULLER	95760-TB-5
2	1	REMOVER BODY	95760-TB-4
3	1	DOWEL PIN	95760-TB-1
4	1	BRASS WASHER	1099
5	1	NUT	1098
6	1	INSTRUCTION SHEET	2309-IS

## INNER CAM BEARING REMOVER TOOL

Use this tool to easily remove the inner cam bearing. Works the same as JIMS® EVO Cam tool No.95760-TB. Insert puller collet into the cam bearing I.D. Insert dowel pin, place remover body over collet, lube threads and with hand tools the bearing is pulled from case. This precision tool will also keep all pin bearings from falling into the engine case. Install JIMS new cam bearings No.8991K with JIMS Tool No.787. *For more details see No.993-IS instructions.*

**No.993** - Use on all T/C, 2006-present Dyna™ and 2007 FLHT & FXST.

### PARTS AVAILABLE SEPARATELY

NO.	QTY.	DESCRIPTION	PART NO.
1	1	PULLER	993-1
2	1	REMOVER BODY	993-2
3	1	DOWEL PIN	95760-TB-1
4	1	BRASS WASHER	1099
5	1	NUT	1098
6	1	INSTRUCTION SHEET	993-IS

## SPORTSTER® CAM BEARING REMOVER

Use to remove inner cam bearings without splitting cases. Easily pulls bearings from case, also keeps rollers from coming out during removal. Install a new JIMS No.9057 performance bearing using JIMS tool No. 97273-60 on this application. *For more details see No.2306-IS instructions.*

**No.95760-XL** - Use on all Sportster® 1957-90. Use on Buell® 1987-90.

### PARTS AVAILABLE SEPARATELY

NO.	QTY.	DESCRIPTION	PART NO.
1	1	PULLER	95760-XL-5
2	1	REMOVER BODY	95760-XL-4
3	1	DOWEL PIN	95760-XL-1
4	1	BRASS WASHER	2126
5	1	NUT	2000
6	1	INSTRUCTION SHEET	2306-IS

# CAM BEARING INSTALLER TOOLS

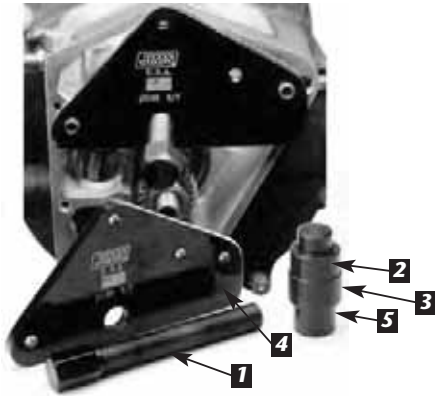

## INNER CAM BEARING INSTALLATION TOOL

This tool easily presses the inner cam bearing smoothly into the right case, with the cases assembled, to

the proper depth. Use a new JIMS performance bearing No.9058 and to remove old use tool No. 95760-TB. For more details see No.2188-IS instructions.

No.2188 - Use on all Big Twin 1958-present single cam only. (**NOTE:** Includes aftermarket motors.)

### PARTS AVAILABLE SEPARATELY

NO.	QTY.	DESCRIPTION	PART NO.
1	1	SCREW	1024
2	1	TOOL, CAM BEARING	97272-60
3	1	O-RING	2310
4	1	PLATE	2188-1
5	1	TOOL, DRIVER, CAM BEARING	2190
6	1	INSTRUCTION SHEET	2188-IS

## TWIN CAM INNER CAM BEARING INSTALLER

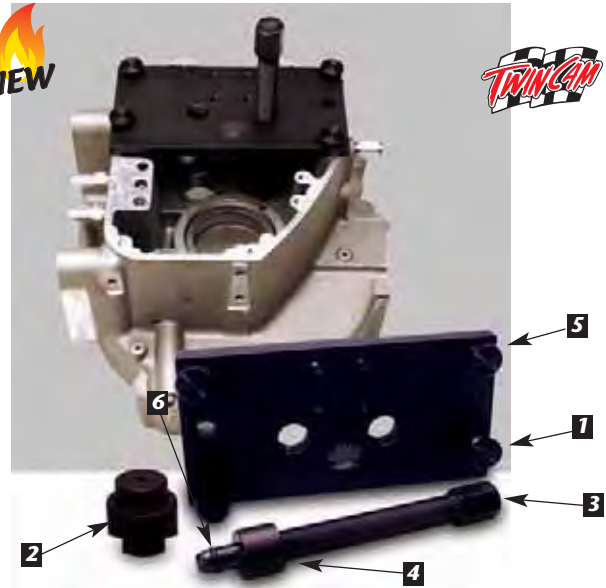

Use this tool to press in, and install, the two inner cam bearings JIMS® No.8991K. This tool has been designed to press from the letter side of the inner cam bearings, by putting all the pushing pressure to the very outer wall of bearing shell. Eliminats any damage to the bearings, cam and cases. This tool will stop at the case and set the bearing depth to .023" to .028" below the case surface. Use with JIMS® Tool No.1279 to remove bearings. For more details see No.787-IS instructions.

No.787 - Use on all T/C, 1999-present.

### PARTS AVAILABLE SEPARATELY

NO.	QTY.	DESCRIPTION	PART NO.
1	1	PLATE INSTALLER	1278-1
2	1	INNER CAM BEARING INSTALLER	1278-3
3	1	SCREW	1024
4	1	SPUD CAM BEARING TOOL	2190
5	4	KNURLED SCREWS	1213
6	1	O-RING	2310
7	1	INSTRUCTION SHEET	787-IS



### RACE & BEARING INSTALL TOOL HANDLE

Use with No.s 33071-73, 34810-84, 94547-80A & B, 97272-60, and 97273-60. Approximately 12" long. For more details see No.33416-80-IS instructions.

No.33416-80

### PARTS AVAILABLE SEPARATELY

NO.	QTY.	DESCRIPTION	PART NO.
1	1	O-RING	2310

9



## CAM BEARING TOOL

Use to install inner cam bearing, with Handle No. 33416-80 on right (Handle slips through the outer cam bushing for alignment). All of JIMS® bearing installers are

designed with an angle to apply all the pushing force to the extreme outer diameter of the bearing. For more details see No.97272-IS instructions.

No.97272-60 - Use on all Big Twin 1958-present single cam only.

(Note: Includes aftermarket motors.)

No.97273-60 - Use on all Sportster® 1957-90.

Use on Buell® 1987-90.

For more details see No.97273-IS instructions.



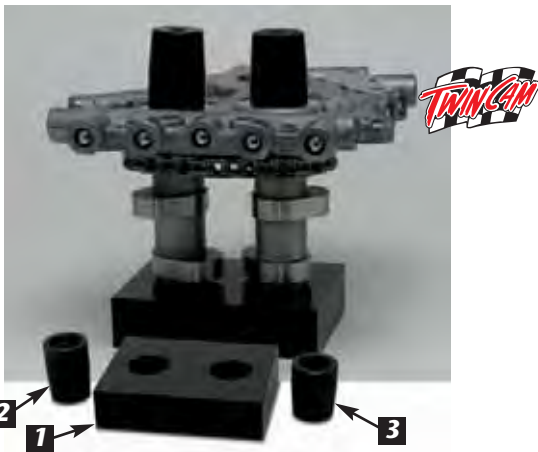

## CAM ASSEMBLY TOOL

Use to hold both cams in an upright position while lowering the cam support plate over both guides and cam journal guides. This tool has been manufactured from a non-marring material that will not damage any of the cams' surfaces. *For more details see No.990-IS instructions.*

No.990 - Use on all T/C, 2006-present Dyna™ and 2007-present FL & FXST.

### PARTS AVAILABLE SEPARATELY

NO.	QTY.	DESCRIPTION	PART NO.
1	1	BASE	990-1
2	1	FRONT GUIDE	990-2
3	1	REAR GUIDE	990-3
4	1	INSTRUCTION SHEET	990-IS



## CAM BUSHING LINE REAMER TOOL

Use to line ream cam cover bushing to size, from inner cam bearing, for a true centerline between the two dimensions. Finish size will be about .0008"-.0015" over the cam journal. *For more details see No.1023-IS instructions.*

No.1023-70 - Use on all Big Twin 1970-present single cam only. (**NOTE:** Includes aftermarket motors.)

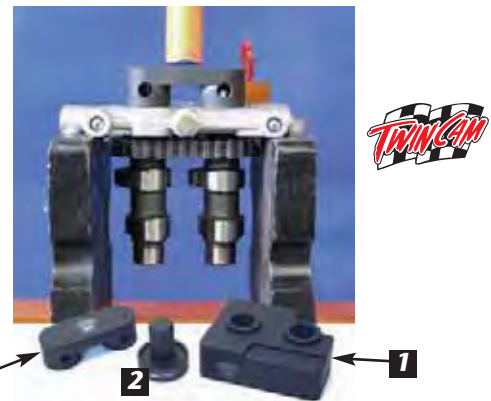

## CAMSHAFT REMOVER & INSTALLER

This multi-function tool will remove and replace front and rear camshafts and the ball bearings in the Twin Cam 88®. It provides the precision alignment of the camshaft to ensure a smooth press in and out of the support plate. *For more details see No.1277-IS instructions.*

No.1277 - Use on all Twin Cam® 1999 to early 2000 to remove & install cams & bearings.

Use on all Late 2000-06 FXST, FL & Late 2000-05 FXD to remove & install cams only.

### PARTS AVAILABLE SEPARATELY

NO.	QTY.	DESCRIPTION	PART NO.
1	1	TWIN CAM SUPPORT BLOCKS	1277-1
2	1	CUP, TWIN CAM TOOL	1277-2
3	1	PILOT, INSTALLER TWIN CAM	1277-3
4	1	INSTRUCTION SHEET	1277-IS

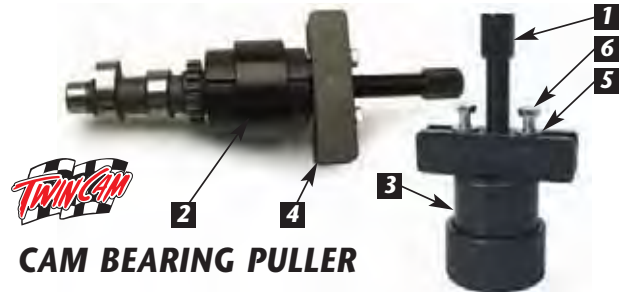

## CAM BEARING PULLER

Once the camshafts are removed from the support plate this specialty tool will remove the bearing from the camshaft. Unlike a general purpose puller this tool was designed to remove the bearing straight with no slipping or binding. *For more details see No.1280-IS instructions.*

No.1280 - Use on all Twin Cam® 1999 to early 2000 for removal of bearings. Use on all Late 2000-06 FXST, FL & Late 2000-05 FXD for removal of front cam bearing.

### PARTS AVAILABLE SEPARATELY

NO.	QTY.	DESCRIPTION	PART NO.
1	1	SCREW	1024
2	1	RING	1044-TU-2
3	2	BEARING REMOVER SIDES	2305-1
4	1	PULLER BAR	2013
5	2	5/16 HEAVY FLAT WASHER	2014
6	2	BOLT	2003
7	1	INSTRUCTION SHEET	1280-IS



## CAM/CRANK SPROCKET LOCK TOOL

This precision tool allows the technician to lock the camshaft and crankshaft sprockets to properly remove, replace and torque the sprocket bolts. This tool is made from non-marring Delrio. *For more details see No.1285-IS instructions.*

No.994 - Use on all T/C, 2006-present Dyna™ and 2007-present FL & FXST.

No.1285 - Use on all Twin Cam®, 1999-06 FL, 1999-05 FXD, and 2000-06 FXST.



## CAM BEARING & BUSHING ALIGNMENT TOOL

Use to check the alignment of cam bearing to cam cover bushing to well within .0003" of centerline. Any binding of this tool indicates misalignment of cam cover, and or bushing. A must for engine builders! *For more details see No.2280-IS instructions.*

No.2280 - Use on all Big Twin 1970-1999 single cam only. (**NOTE:** Includes aftermarket motors.)

SEE JIMSUSA.COM FOR DETAILED INSTRUCTIONS



## CAM CHAIN TENSIONER TOOL

This tool will unload the pressure on the primary and secondary chain tensioners to assemble and disassemble cams. This tool also checks spring loads on chain tensioners. *For more details see No.1283-IS instructions.*

No.1283 - Use on all 1999-06 FL, 1999-05 FXD, and 2000-06 FXST.

### PARTS AVAILABLE SEPARATELY

NO.	QTY.	DESCRIPTION	PART NO.
1	1	TWIN CAM® CHAIN TENSIONER	1283-1
2	2	HOLD PIN	1283-2
3	1	INSTRUCTION SHEET	1283-IS



## CAM BEARING GAUGE

Inner Cam Bearing Go & No Go Gauge. The only accurate and easy way to check the size of the inside diameter of your inner cam bearing. Use these pins to check if your cam is too tight

or too loose. Some cases and or bearings have too much, or not enough press fit. If the cam is too tight it can eat up the end of the journal, and cause other problems with the cam. If the cam is too loose, it can rock fore and aft causing noise and unnecessary cam, bearing and roller wear. *For more details see No.2249-IS instructions.*

No.2249 - Use on all Big Twin 1958-1999 single cam only. Sold in a set of 2. (**NOTE:** Includes aftermarket motors.)

### PARTS AVAILABLE SEPARATELY

NO.	QTY.	DESCRIPTION	PART NO.
1	1	GO PIN	2249A
1	1	NO-GO PIN	2249B
1	1	INSTRUCTION SHEET	2249-IS



## **TWIN CAM 88° CAM RELIEF TOOL SINGLE SPINDLE**

Use this tool to cleanly remove case material for larger than stock cams. This tool features one spindle cutter and must be remounted to clearance opposite cam side. This tool is easy to use and can be powered by a standard drill motor with a 1/2" chuck.

No.1410 - Use on all Twin Cam®, 1999-05 FXD, 1999-06 FL, and 2000-06 FXST engine cases.

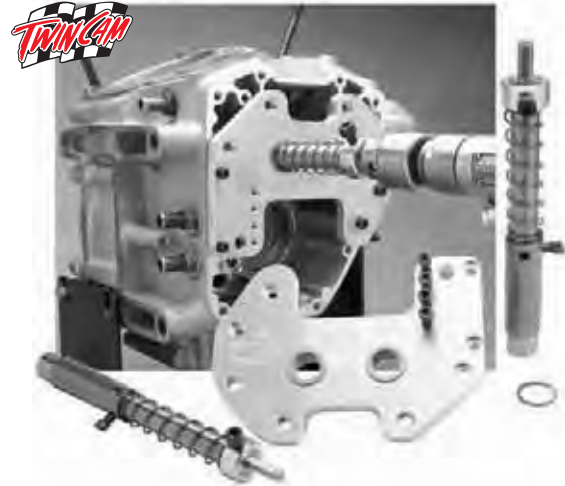

## **TWIN CAM 88° CAM RELIEF TOOL DUAL SPINDLE**

Use this tool to cleanly remove case material for larger than stock cams. This tool features two spindle cutters to reduce setup time. This tool is easy to use and can be powered by a standard drill motor with a 1/2" chuck.

No.1411 - Use on all Twin Cam®, 1999-05 FXD, 1999-06 FL, and 2000-06 FXST engine cases.



## **EVO CAM RELIEF TOOL**

Use this tool to cleanly remove case material for a larger than stock cam. Simply mount this tool and slowly turn in the threaded body as you power it with a standard 1/2" chuck, drill motor.

No.1412 - Use on all Big Twin 1970-99, Single Cam, EVO or Shovel. (**NOTE:** Includes aftermarket motors.)



## **XL CAM RELIEF TOOL**

Use this tool to cleanly remove case material for larger than stock cams. Simply mount this tool and slowly turn in the threaded body as you power it with a standard 1/2" chuck drill motor.

No.1413 - Use on all 1991-Present Sportsters®. Use on 1995-Present Buell®, except 1125R.





## CAM GEAR ALIGNMENT TOOL

This tool is designed to index the cam gear's position while removing or installing the cam gear. This tool will allow you to accurately position and or reposition the cam gear from one camshaft to another, as well as allow you to retard or advance the gear's position by up to 10 degrees with the accuracy of a 1/4 degree. *For more details see No.1290-IS instructions.*

No.1290 - Use on all Single Cam 1970-1999. Use No. 1390 to remove cam gear.



## CAM GEAR REMOVER TOOL

Use to safely remove the cam gear from the camshaft on Big Twins. This precision tool acts as a stable base to keep the camshaft perfectly perpendicular to the press. A 3/8" ball bearing is included to protect the camshaft's end while pressing off the gear. To accurately install the cam gear use JIMS® No.1290 Cam Gear Alignment Tool (above). *For more details see No.1390-IS instructions.*

No.1390 - Use on all 1939-1999 Big Twin camshafts with pressed-on camshaft gears, including aftermarket cams.

Endorsed By

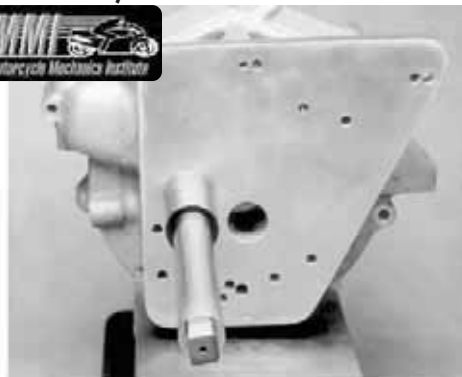

## BREATHER REAMER TOOL

Repair a damaged breather hole with JIMS® Breather Reamer Tool. No need to disassemble the cases. Using JIMS® Reamer Tool will repair a damaged breather hole, to use a .030" oversize breather gear, (see breather gear section in this catalog), in less than an hours time (**NOTE: all holes in breather bore will need to be cleared of all chips**). *For more details see No.1706-IS instructions.*

No.1706 - Use on all Big Twin Single Cam 1936-1999.

### PARTS AVAILABLE SEPARATELY

NO.	QTY.	DESCRIPTION	PART NO.
1	1	BREATHER REAMER	1706-3
2	1	PLATE ASSEMBLY	1706M
4	4	1/4"-20 SCREWS	2135
5	1	INSTRUCTION SHEET	1706-IS
6	4	1/4"-24 SCREWS	2408

**IMPORTANT NOTE:** Some early crankcases 1936-69, have very little material between the breather hole and the air/oil separator cavity below it. Before using the No.1706, measure the wall thickness to verify that the reamer will not break through.

SEE JIMSUSA.COM FOR DETAILED INSTRUCTIONS

Endorsed By



## **BIG TWIN CAM® SEAL INSTALLER AND REMOVER**

- **REMOVES CAM SEAL**
- **INSTALLS CAM SEAL**
- **REMOVES CAM COVER**

Use to install and remove a 1970-1999 cam seal without removing the cam cover. This tool is very simple to use. Just mount tool in cover, screw in the two removing screws, turn center, and out comes the cam seal. The new seal is pressed in with the same tool, square and flat for a no leak fit. ***This tool will also remove cam cover from case.*** For more details see No.2243-IS instructions.

No.2243 - Use on all Big Twin 1970-1999 single cam only.

**NOTE:** When replacing seal, we recommend JIMS seal No.2169. See page 126

### **PARTS AVAILABLE SEPARATELY**

NO.	QTY.	DESCRIPTION	PART NO.
1	1	CLIP	2304
2	2	MACHINE SCREWS	2297
3	2	SCREW	2287
4	1	CUP, INSTALLER & REMOVER, CAM SEAL	2243-4
5	1	SCREW, INSTALLER & REMOVER, CAM SEAL	2243-3
6	1	CAP - USED WHEN REMOVING CAM COVER	2243-2
7	1	PLATE, INSTALLER & REMOVER, CAM SEAL	2243-1
8	1	INSTRUCTION SHEET	2243-IS

Endorsed By



## **CAM BUSHING INSTALLER DRILL JIGS**

Just press in new JIMS® cam bushing with jig and drill through guide hole in jig, through both bushing and cam cover. Press in new staking pin No.2201, and bushing is locked in place. Jig comes complete with instructions. Use to install and drill dowel pin hole in cam bushing to the factory specification. Supplied with drill.

### **FOR JIMS® BUSHING NO.25581-36 & NO.25597-36**

No.1011-36TB - Use on all Big Twin 1936-69. For more details see No.1011-IS instructions.

### **FOR JIMS BUSHING NO.25581-70**

No.1012-70TB - Use on all Big Twin 1970-present single cam only.

(NOTE: Includes aftermarket motors.)

For more details see No.1012-IS instructions.

### **FOR JIMS BUSHING NO.25586-37**

No.1017-37TB - Use on all Sportster® 1954-present. Use on Buell® 1987-2006. Use on Big Twin 1937-48 Sidevalves. For more details see No.1017-IS instructions.



### **NO.31 SIZE DRILL - JOBBER H.S.S.**

Use with all JIMS® drill jigs that use JIMS® No.2201K staking pin. These drills are ultra sharp for the safest possible drilling.

No.1097 - Use on all models.



## A MUST FOR CHROME OR POLISHED COVERS CAM COVER HOLDING TOOL

Use to hold cam cover for removing and installing bushings. Clamps in vice or Bridgeport® mill. Holds cam cover flat and keeps it from being scratched. *For more details see No.1041-IS instructions.*

No.1041-TC - Use on all Big Twin 1973-1999 single cam only. (**NOTE:** Includes aftermarket motors.)

### PARTS AVAILABLE SEPARATELY

NO.	QTY.	DESCRIPTION	PART NO.
1	2	HOLD DOWN SCREWS	1041-TC-3
2	1	RISER	1041-TC-2
3	1	RISER SCREW	1096
4	1	INSTRUCTION SHEET	1040-IS



## STAKING DOWEL PIN FOR BUSHINGS

Use on all bushings. These pins hold bushing in place. Use with JIMS® bushing installers drilling jigs. Sold in a pack of 10. Replaces H.D. No.275.

No.2201K - Use on all models.

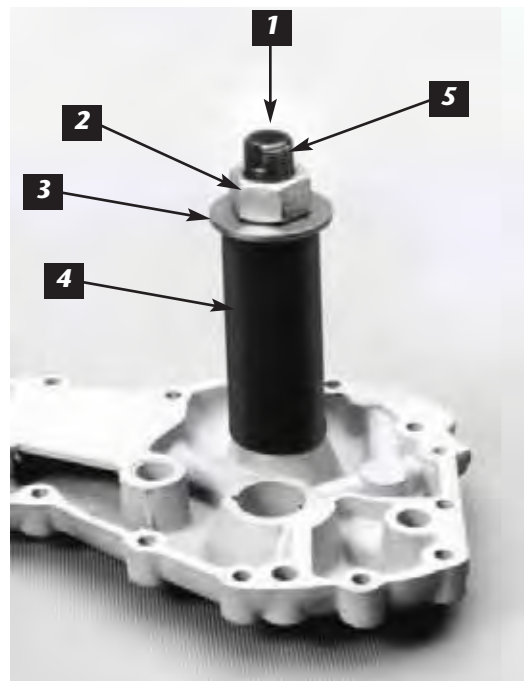

## CAM COVER BUSHING REMOVER

Use this tool to remove the cam cover bushing. This sturdy and reliable tool will remove the cam cover & cam bushing in one easy operation. Will also remove cam bushing in case. *For more details see No.2281-IS instructions.*

No.2281 - Use on all Big Twin 1936-1969.

### PARTS AVAILABLE SEPARATELY

NO.	QTY.	DESCRIPTION	PART NO.
1	1	DOWEL PIN	95760-TB-1
2	1	NUT	1098
3	1	BRASS WASHER	1099
4	1	BODY	2281-1
5	1	PULLER	95760-TB-5
6	1	INSTRUCTION SHEET	2281-IS







## CAM AND PINION GEAR GAUGE PINS

Use to check pinion and cam gears for pitch diameters. A complete sizing chart is included with the .105" gauge pins.

For more details see No.1111-IS instructions.

- No.1110 - 0.105" pins, sold in a set of 2. Use on all Big Twin 1954-89.
- No.1111 - 0.108" pins, sold in a set of 2. Use on all Big Twin 1990-present single cam only. **(NOTE: Includes aftermarket motors. See H-D® service manual for sizing charts.)**



## PINION BUSHING PULLER

Use to remove pinion bushing from cam cover in one easy operation. Use with JIMS® tool No.1041-TC, cam cover holder. For more details see No.2308-IS instructions.

- No.95760-TP - Use on all Big Twin 1954-1999 single cam only. **(NOTE: Includes aftermarket motors.)**

### PARTS AVAILABLE SEPARATELY

NO.	QTY.	DESCRIPTION	PART NO.
1	1	DOWEL PIN	2142
2	1	NUT	2128
3	1	BRASS WASHER	2129
4	1	BODY	95760-TP-4
5	1	PULLER	95760-TP-5
6	1	INSTRUCTION SHEET	2308-IS

## NO.31 DRILL - JOBBER H.S.S.

Use with all JIMS® drill jigs that use JIMS® 2201-P dowel pin. These drills are ultra sharp for the safest possible drilling.

No.1097



Endorsed By



## PINION BUSHING INSTALLER DRILL JIGS

Just press in JIMS® pinion bushing with jig, and drill through guide hole in jig - through both bushing and cam cover. Press in new staking pin JIMS® No.2201,

and bushing is locked in place. Jig comes complete with instructions. Use to install and drill staking pin hole in cam or pinion bushing to the factory location. Supplied with drill size No. 31. Use JIMS® No.2201K for staking pins.

## PINION BUSHING INSTALLER DRILL JIGS

### FOR JIMS® BUSHING NO.25582-36

No.1018-37TB - Use on all Big Twin 1936-53. For more details see No.1018-IS instructions.

### FOR JIMS® BUSHING NO.25591-37

No.1015-37TB - Use on all Big Twin 1937-48 Sidevalves. For more details see No.1015-IS instructions.

### FOR JIMS® BUSHING NO.25582-54/73

No.1013-54TB - Use on all Big Twin 1954-92. For more details see No.1013-IS instructions.

### FOR JIMS® BUSHING NO.25593-37

No.1016-37TB - Use on all 45" 1937-73. For more details see No.1016-IS instructions.





## PUSHROD COVER SEAL/SEAT CUTTER

Use to correct any misalignment with pushrod cover O-ring seats when pushrod covers refuse to seal. This tool is simple to use, and a must have for any professional. Instructions included.

No.1420 - Use on all Big Twin 1984-99.  
Use on all Sportster® 1986-90.  
**(NOTE: Includes aftermarket motors.)**



## LATE SHOVEL & EVO TAPPET BLOCK ALIGNMENT TOOL

1/4"-20 threads

Use to align oil hole from crank case to tappet block. Get two, and use to align rocker boxes on Evo style heads including, XL, Buell®, & Buell® Blast. Also used in Twin Cam® oil pump alignment applications. For more details see No.33443-IS instructions.

No.33443-84 - Use on all Big Twin Late 1976-present single cam only. **(NOTE: Includes aftermarket motors.)**



## TAPPET BLOCK CLEARANCING CUTTER

Use to clearance tappet blocks for high-lift cams. Removes only the material needed to allow the tappet roller to clear the tappet block. Produces professional results in minutes.

No.1419 - Use on all Big Twin EVO 1984-99.  
Use on all Sportster® 1986-90.  
**(NOTE: Includes aftermarket motors.)**

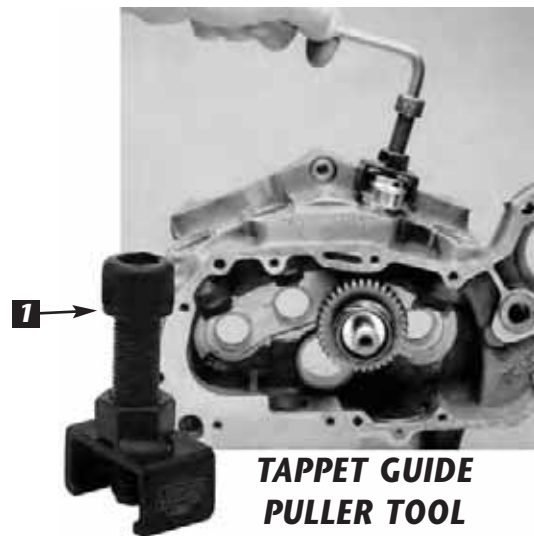

## TAPPET GUIDE PULLER TOOL

Use to remove press fit tappet guides from crankcase. For more details see No.95724-IS instructions.

No.95724-57 - Use on all Sportster® 1957-78.

### PARTS AVAILABLE SEPARATELY

NO.	QTY.	DESCRIPTION	PART NO.
1	1	SCREW	2130
2	1	INSTRUCTION SHEET	95724-IS

## WRIST PIN BUSHING REAMER TOOL

(Note use with rods in or out of motor)

Use this kit to ream your wrist pin bushings to H-D® specifications. These reamers are made to exact tolerances, piloted to locate from the I.D. of your newly replaced JIMS® wrist pin bushings. Reams are easy to use with their designed lead in taper at the start of each ream. Use JIMS® No.1284 Rod Clamp tool. For more details see No.1726-IS instructions.



- No.1726-3 - Use on Twin Cam® 1999-2005 FXD, 1999-2006 FL, & 2000-2006 FXST.
- No.1726-1 - Use on all Big Twins that use the late diameter size wrist pins 1973 to present (**NOTE:** Includes aftermarket motors.)
- No.1726-2 - Use on all Sportsters® 1957-present and Buell® 1987-present, except 1125R.

**NOTE:** Some wrist pin bushings will need a small amount of ball honing to give specified fit, see H-D® service manual for specifications.

Endorsed By



## ROD ALIGNMENT TOOL

Use to check rod straightness without removing rods from case. The alignment tool is 4-1/2" long. For more details see No.1010-IS instructions.

- No.1158 - Use on JIMS® Twin Cam® Rods (.827" Wrist Pin)
- No.1148 - Use on all Twin Cam® 'A' and 'B'. (**NOTE:** Includes aftermarket motors.) (.927" Wrist Pin)
- No.1010 - Use on all Big Twin single cam (.791" Wrist Pin)

## ROD HOLDER TOOL

Use to keep connecting rods in place and eliminate twisting or bending of the connecting rod while reaming or honing the wrist pin bushings. Works well with JIMS® No.1051, 95970-32C wrist pin bushing tools, and JIMS® No.1726-1, 1726-2 and 1726-3 wrist pin bushing reamers. For more details see No.1284-IS instructions.



- No.1284 - Use on all Twins and Buell®Blast. Includes Twin Cam® 'A' and 'B'.

### PARTS AVAILABLE SEPARATELY

NO.	QTY.	DESCRIPTION	PART NO.
1	1	CLAMP BASE	1284-1
2	2	HOLD DOWN NUT, T/C	1284-2
3	2	HOLD DOWN NUT, EVO	1284-3
4	2	THUMB SCREW	1286
5	1	INSTRUCTION SHEET	1284-IS



## CONNECTING ROD BUSHING TOOL

Use to remove and replace wrist pin bushings without removing connecting rods from crankcases. Use JIMS® No.1284 Rod Holder tool. For more details see No.95970-IS or No.1051-IS instructions.

- No.1051 - Use on all 1999-2006 FL, 1999-2005 FXD, & 2000-2006 FXST.
- No.95970-32C - Use on all single cam Big Twins, XL's, Buell's, and 45's.

### PARTS AVAILABLE SEPARATELY

NO.	QTY.	DESCRIPTION	PART NO.
1	1	BOLT	2009
2	2	BRASS WASHER	2129
3	1	SLIDER	1051-1 OR 95970-32C-1
4	1	PULLER	1051-2 OR 95970-32C-2
5	1	BEARING	2010
6	1	COUPLING NUT	2011
7	1	INSTRUCTION SHEET	1051-IS & 95970-IS



# ROD & WRIST PIN TOOLS

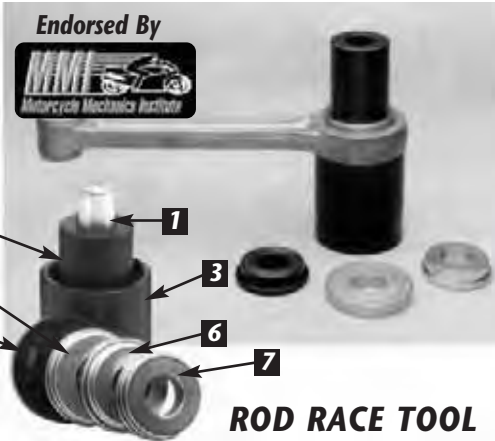

**ROD RACE TOOL**

Supports both sides of rod as races are removed or replaced, minimizing the possibility of distortion to female rod or race.

See No.5 - New design for installing male rod race. This new washer will center the race in the middle of the rod. For more details see No.1003-IS instructions.

No.1003 - Use on all Twins that have replaceable races. (NOTE: Includes aftermarket engines.)

### PARTS AVAILABLE SEPARATELY

NO.	QTY.	DESCRIPTION	PART NO.
1	1	TOOL BASE AND STUD PILOT	1003-0
2	1	ROD RACE TOOL PUSH PLUG	1003-6
3	1	2-1/4" SLEEVE	1003-2
4	1	ROD RACE TOOL COLLAR 1.80" 74 & 80	1003-4
5	1	ROD RACE TOOL COLLAR 1.990" 74 & 80	1003-5
6	1	ROD RACE TOOL COLLAR 1.740" 45 INCH	1003-8
7	1	ROD RACE TOOL COLLAR 1.650" 45 INCH	1003-7
8	1	INSTRUCTION SHEET	1003-IS



### WRIST PIN CLIP REMOVER & INSTALLER

Use this tool to easily remove and install wire type wrist pin clips without damage to the piston.

No.769 - Use on all O.E.M. Twin Cam 1999-Present.

No.1172 - Use on all O.E.M. pistons 1984-99 EVO.



**ROD LAPPING SET**

Arbor assembly includes 1-1/2" and 1-5/8" laps. For lapping compound, use JIMS® No.1083 Course, No.1084 Fine. For more details see No.96740-IS instructions.

No.96740-36 - Use on all Twins that have replaceable races. (NOTE: Includes aftermarket engines.)

### PARTS AVAILABLE SEPARATELY

NO.	QTY.	DESCRIPTION	PART NO.
1	1	MAIN BODY	96740-36-1
2	1	ADJUST COLLAR	96740-36-2
3	1	COLLAR	2131
4	1	LAP HEAD 1-1/2" OD	96740-36-4
5	1	LAP HEAD 1-5/8" OD	96740-36-5
6	1	HEX HEAD NUT	2000
7	1	INSTRUCTION SHEET	96740-IS



**TWIN CAM® WRIST PIN REMOVER & INSTALLER**

This new JIMS® tool will cut the time it takes to remove and install wrist pins. This simple tool can be used easily by one person. No need to get another technician to hold the piston while you drift the pin in or out. For more details see No.1276-IS instructions.

No.1276 - Use on all 99-06 FL, 99-05 FXD & 00-06 FXST.

### PARTS AVAILABLE SEPARATELY

NO.	QTY.	DESCRIPTION	PART NO.
1	1	NUT	2035
2	1	HANDLE, LOCK, REMOVER, WRIST PIN	1276-5
3	1	HANDLE, REMOVER, WRIST PIN	1276-4
4	1	WASHER, REMOVER, WRIST PIN	1276-3
5	1	DELRIO GUIDE SHAFT, REMOVER, WRIST PIN	1276-2
6	1	ROD, REMOVER, WRIST PIN	1276-1
7	1	INSTRUCTION SHEET	1276-IS



# WRIST PIN AND PISTON TOOLS



## PISTON PIN KEEPER TOOL

Use to install retaining ring in piston. This tool will install "Round Circlip" rings in one easy step without distorting ring, for the safest wrist pin retention possible. *For more details see No.34623-IS instructions.*

No.34623-83 - Use on all Big Twin 1983-present single cam only. (**NOTE:** Includes aftermarket motors.)

Use on all Sportster® Late 1985-present. Use on Buell® 1987-2010, except 1125R.

### PARTS AVAILABLE SEPARATELY

NO.	QTY.	DESCRIPTION	PART NO.
1	1	PIN	34623-83-1
2	1	COLLAR	34623-83-2
3	1	INSTRUCTION SHEET	34623-IS



## PISTON PIN KEEPER TOOL

For installing and removing split "L" ring keepers. *For more details see No.2368-IS instructions.*

No.96780-32A - Use on all Big Twin 1932-72.

### PARTS AVAILABLE SEPARATELY

NO.	QTY.	DESCRIPTION	PART NO.
1	1	MANDREL	96780-32A-1
2	1	SLEEVE	96780-32A-2
3	1	INSTRUCTION SHEET	2368-IS



## PISTON SUPPORT PLATE

Using this tool will give you peace of mind when installing your rings and cylinders by providing a non-marring flat support to push the bottom of the piston against as you install the rings and cylinder over the piston. *For more details see No.1164-IS instructions.*

No.1164 - Use on all H-D® style engines.

### PARTS AVAILABLE SEPARATELY

NO.	QTY.	DESCRIPTION	PART NO.
1	1	PISTON PLATE	1164-1
2	2	DELRIO NUT	1164-2
3	2	SCREW	1690
4	1	INSTRUCTION SHEET	1164-IS

## PISTON LOCK RING TOOL

Use to install lock ring H-D® No. 22582-52 in piston having .515" I.D. wrist pins, like most aftermarket pistons. This tool will install "spiral lock" rings in one easy step without distorting ring, for the safest wrist pin retention possible. *For more details see No.96780-IS instructions.*

No.96780-58A - Use on all Big Twin and Sportster® 1973 and earlier. Use to install lock ring H-D® No.22582-52 in piston having .535" I.D. wrist pins.

No.96781-72 - Use on Big Twin and Sportster® 1973-77.



### PARTS AVAILABLE SEPARATELY

NO.	QTY.	DESCRIPTION	PART NO.
1	1	COLLAR	2148
2	1	INSTRUCTION SHEET	96780-IS

# PISTON RING TOOLS

## PISTON RING EXPANDER TOOL



Use to remove and install piston rings. Reduces the risk of ring breakage. This tool has tapered jaws to hold all normal size rings from 3/64" to 1/4" ( 1.2 - 6.3mm) thickness.

No.1235 - Use on all piston rings.

**NEW**



## ANGLED FEELER GAUGE

This new innovative feeler gauge holder eliminates the need to use bulky multi feeler gauge tools while performing valve adjustments. This tool is ideal for reaching down into small tight areas and incorporates an angle to help reach around corners, often necessary for adjusting valves. Tool includes two handles with: .002", .003", .004", .005", .006" and .008" inserts and an allen wrench. For more details see No.908-IS instructions.

No. 908 - Feeler Gauge Kit

## PISTON RING END GAP TOOL FOR TWIN CAM PISTONS & JIMS ENGINES

**NEW**



No.3201

No.3200

This is another unique tool by Hiro Koiso. This tool makes measuring ring end gap faster, more accurate and eliminate the guess work. The flanged design allows the piston ring to fit squarely in cylinder bore every time. This is the first tool to designed to be able to test oil ring gaps by a proprietary cutout feature. Just install any ring, top, 2nd, or oil control rails on the tool. Install tool into a cylinder bore and then view the ring end gap in the "Key Slot". Use a feeler gauge to get your end gap measurement. Each side of the tool is made for checking a standard size piston rings. For more details see No.3200-IS instructions.

No. 3200 – Use on H-D Twin Cam standard size pistons for 95" 103" or 110", with 3.875" or 4.000" bore.

No. 3201 - Use on JIMS Twin Cam motor standard size pistons for 120", 131", 135", with 4.125" or 4.310" bore.

## PARTS AVAILABLE SEPARATELY

NO.	QTY.	DESCRIPTION	PART NO.
1	2	HOLDER, FEELER GAUGE	908-1
2	2	6-32 X 3/8 BUTTON HEAD, SOCKET	1247
3	1	.002"=.05MM, BLADE, FEELER GAUGE	908-02
4	1	.003"=.08MM, BLADE, FEELER GAUGE	908-03
5	1	.004"=.10MM, BLADE, FEELER GAUGE	908-04
6	1	.005"=.13MM, BLADE, FEELER GAUGE	908-05
7	1	.006"=.15MM, BLADE, FEELER GAUGE	908-06
8	1	.008"=.20MM, BLADE, FEELER GAUGE	908-08
9	1	.009"=.229MM, BLADE, FEELER GAUGE	908-09
10	1	.010"=.254MM, BLADE, FEELER GAUGE	908-10
11	1	.011"=.279MM, BLADE, FEELER GAUGE	908-11
12	1	1" KEY RING (NOT SHOWN)	2213
13	1	908-IS INSTRUCTION SHEET	908-IS



# PISTON RING TOOLS



## PISTON RING COMPRESSOR SET

Supplied with 6 bands ranging from 2-7/8" to 4-3/8". Fine tooth ratcheting motion to compress bands in small increments for accurate compression (Will not break or damage rings).

No.1236 - Use on all models.



## PISTON RING END GAP GRINDER TOOL

This handy American Made, hand operated tool will assist you in grinding the correct piston ring end gap. It can be mounted on a bench or used in a vice. Allows the builder to easily tailor the end gaps of their rings for close fitment to maintain a complete combustion seal.

No.1255 - Ring grinder tool.

No.1256 - Replacement blade for above.



## PISTON RING COMPRESSOR

JIMS is now offering a ring compressor set for 50cc bikes using 1.875" (22mm ) to larger bikes 2.875" ( 73mm) piston sizes. This tool will also fit the Harley 45 model and all the smaller motorcycles, including Asian, and European models. For sizes larger use JIMS No.1236.

No. 910 - Use on piston diameter sizes from 1.875" (22mm ) to 2.875" ( 73mm ).

11



## PISTON RING GROOVE CLEANER

Use this tool to remove carbon build-up from the two piston compression ring slots. This tool includes two cleaning spurs with sizes: 5/64", 3/32", 1/8", 5/32", 3/16", 1/4", 1.5mm, 1.75mm, 2mm.

No.1765 - Use on all 2 3/4" to 5" diameter.

SEE JIMSUSA.COM FOR DETAILED INSTRUCTIONS

# CYLINDER TOOLS

## CYLINDER TORQUE PLATE KITS

Late model aluminum cylinders cannot be accurately honed without using torque plates. These plates simulate operating stress conditions when boring or honing aluminum cylinders. These plates easily adapt to conventional boring bars or a Sunnen type honing machine. The JIMS® torque plates are drilled precisely for multiple applications use, and can accommodate various bore sizes, with stock or oversize big bores. These kits are lasered lettered for ease of use with torquing sequence and most sets don't require removal of ring dowels. Refer to chart for sizes and applications available. For more details see parts list for instructions sheet part number.



PART NO.	APPLICATION	BORE SIZE
No.1073	Use on Shovel and Evo, 1966 to present Big Twin, Single cam only. Includes aftermarket and S&S® motors. Use on Sportster® 1986-present, Buell® 1987 to present, except 1125R. <b>NOTE:</b> On Sportster® or Buell® you must order torque plate bolts separately No.2144.	3.4375" - 4"
No.2144	Torque Plate bolt kit for Sportster® and Buell®. (For use with No.1073)	
No.930	JIMS® T/C Big Bore Cyl's, H-D®, Bigger Bore Cyl's with O.E.M. bolt pattern 99 to present	4" - 4.060"
No.951	H-D® Twin Cam® 88, 96, 103" with O.E.M. bolt pattern. 1999 to present.	3.75" - 3.875"
No.1208-1316	120" JIMS® Twin Cam® Engines 1999 to present.	4.125"
No.1308-1316	131" or 135" JIMS® Twin Cam® Engines 1999 to present.	4.3125"
No.931	Custom Chrome 100	3.8125"
No.932	Custom Chrome 100 / 110	4"

### No.930 PARTS AVAILABLE SEPARATELY

NO.	QTY.	DESCRIPTION	PART NO.
1	1	BOTTOM TORQUE PLATE	1287-1
2	1	TOP TORQUE PLATE	930-2
3	4	ALLEN BOLTS	1208
4	1	TORQUE PLATES, TAB	1073-2
5	2	SOCKET HEAD SCREW	2405
6	4	3/8" WASHER	1265
7	1	INSTRUCTION SHEET	930-IS

### No.931 PARTS AVAILABLE SEPARATELY

NO.	QTY.	DESCRIPTION	PART NO.
1	1	BOTTOM TORQUE PLATE	931-1
2	1	TOP TORQUE PLATE	931-2
3	4	ALLEN BOLTS	1208
4	1	TORQUE PLATES, TAB	1073-2
5	2	SOCKET HEAD SCREW	2405
6	4	3/8" WASHER	1265
7	1	INSTRUCTION SHEET	931-IS

### No.932 PARTS AVAILABLE SEPARATELY

NO.	QTY.	DESCRIPTION	PART NO.
1	1	BOTTOM TORQUE PLATE	932-1
2	1	TOP TORQUE PLATE	932-2
3	4	ALLEN BOLTS	1208
4	1	TORQUE PLATES, TAB	1073-2
5	2	SOCKET HEAD SCREW	2405
6	4	3/8" WASHER	1265
7	1	INSTRUCTION SHEET	931-IS

SEE JIMSUSA.COM FOR DETAILED INSTRUCTIONS

# CYLINDER TOOLS



**NOTE:** See part list charts on previous page and below.

## No.1073 PARTS AVAILABLE SEPARATELY

NO.	QTY.	DESCRIPTION	PART NO.
1	1	BOTTOM TORQUE PLATE	1073-1
2	1	TOP TORQUE PLATE	1073-4
3	4	ALLEN BOLTS	1208
4	1	TORQUE PLATES, TAB	1073-2
5	2	SOCKET HEAD SCREW	2405
6	4	3/8" WASHER	1265
8	4	SET SCREW SHOVEL	1209
7	1	INSTRUCTION SHEET	1073-IS

## No.951 PARTS AVAILABLE SEPARATELY

NO.	QTY.	DESCRIPTION	PART NO.
1	1	BOTTOM TORQUE PLATE	1287-1
2	1	TOP TORQUE PLATE	951-2
3	4	ALLEN BOLTS	1208
4	1	TORQUE PLATES, TAB	1073-2
5	2	SOCKET HEAD SCREW	2405
6	4	3/8" WASHER	1265
7	1	INSTRUCTION SHEET	930-IS

## No.1208-1316 PARTS AVAILABLE SEPARATELY

NO.	QTY.	DESCRIPTION	PART NO.
1	1	BOTTOM TORQUE PLATE	1208-1602
2	1	TOP TORQUE PLATE	1208-1601
3	4	ALLEN BOLTS	1208
4	1	TORQUE PLATES, TAB	1073-2
5	2	SOCKET HEAD SCREW	2405
6	4	3/8" WASHER	1265
7	1	INSTRUCTION SHEET	1208-1350

## No.1308-1316 PARTS AVAILABLE SEPARATELY

NO.	QTY.	DESCRIPTION	PART NO.
1	1	BOTTOM TORQUE PLATE	1308-1602
2	1	TOP TORQUE PLATE	1308-1601
3	4	ALLEN BOLTS	1208
4	1	TORQUE PLATES, TAB	1073-2
5	2	SOCKET HEAD SCREW	2405
6	4	3/8" WASHER	1265
7	1	INSTRUCTION SHEET	1208-1350



Endorsed By



## EVO CYLINDER STUD JIG ASSEMBLY

Use to repair stripped or damaged cylinder stud case threads up to a 4" bore. This tool will hold centerline and squareness to where the factory intended them to be. All this with the engine still in the frame using an angle head drill (drill not included). *For more details see No.1000-IS instructions.*

No.1000A - Use on Big Twin 1984-1999 single cam only. (**NOTE:** Includes aftermarket motors.) Use on Sportster 1986-1999, & Buell® 1987-present, except 1125R.

**\*NOTE:** Sportster® & Buell® will need shorter stud spacers. Order separately to modify.

## PARTS AVAILABLE SEPARATELY

NO.	QTY.	DESCRIPTION	PART NO.
1	1	CYLINDER JIG	1000A-1
2	2	STUD SPACER TUBES	1000A-2
3	2	.378" ID X 3/4" OD X 3/4" BUSHING	1000A-4
4	1	.397" ID X 3/4" OD X 3/4" BUSHING	1000A-5
5	1	.468" ID X 3/4" OD X 3/4" BUSHING	1000A-6
6	1	.486" ID X 3/4" OD X 3/4" BUSHING	1000A-7
7	1	.572" ID X 3/4" OD X 3/4" BUSHING	1000A-8
8	2	.500" ID X 3/4" OD X 3/4" BUSHING	1000A-3
9	2	SHOULDER BOLT	1000A-9
10	2	FLAT WASHER	2031
11	1	INSTRUCTION SHEET	1000-IS

SEE JIMSUSA.COM FOR DETAILED INSTRUCTIONS





## "EVO" CASE BORING TOOL

This EVO case boring tool takes all the guesswork out of boring the EVO style (H-D® or aftermarket) engine case cylinder spigot bore. Stock 80" EVO has a 3.5" cylinder bore. Tool will bore any EVO style engine case with stock bolt pattern, up to 3.8125". For more details see No.1177-IS instructions.

No.1409 - Use on 1984-99 EVO style engine cases. Bore from stock bore size to 3.8125" bore size. Will work with aftermarket engine cases that utilize stock location of cylinder stud holes, and overall case widths.

### PARTS AVAILABLE SEPARATELY

NO.	QTY.	DESCRIPTION	PART NO.
1	1	MOUNTING PLATE	1177-1
2	1	BASE PLATE	1177-2
3	1	ALIGNMENT PLATE, CASE BORING TOOL, EVO	1177-3
4	1	BORING HEAD, BORING ASSEMBLY	1177-4
5	1	LOCATING PLATE, BORING ASSEMBLY, EVO	1177-5
6	1	SUPPORT PLATE, BORING ASSEMBLY	1177-6
7	1	SHIELDED BEARING	8149
8	1	PULL OUT DOWEL, 1/2" x 3-1/2"	1685
9	6	3/8-16" x 1" SHCS	1686
10	2	1/4-20" x 1" SHCS	2133
11	4	DOWEL PIN, 1/4" x 3/4"	8093
12	2	BUSHING	1681
13	3	5/16-18" x 1" SHCS	2405
14	2	T-PIN, Ø3/8" SHANK	1687
15	6	TOOL BIT	1688
16	2	1/4-28" x 1/2" SET SCREW	1689
17	1	WASHER, 1/4", SAE	1683
18	1	5/16-18" x 1-3/4" SET SCREW	1200
19	1	5/16-18" NUT	1222
20	1	1/4-20" x 1/2", BHCS	8090
21	3	DOWEL PIN 1/2" x 3-1/2"	1680
22	3	3/8" AN WASHER	1265
23	1	INSTRUCTION SHEET	1177-IS



## TWIN CAM CASE BORING TOOL

Why pay a machine shop to bore your Twin Cam® cases? Use this tool in your own shop and save time and money. This easy to use tool will pay for itself the first time you use it. Designed to be used on a heavy-duty 15" drill press. Bore these new cases with ease (with stock cylinder bolt pattern). Bore cases from a 4" bore to a 4-1/8" bore and build yourself (depending on stroke and bore size) a 100" to 124" Twin Cam® big bore motor. For more details see No.1177-IS instructions.

No.1408 - Use on all Twin Cam®, 1999-present.

### PARTS AVAILABLE SEPARATELY

NO.	QTY.	DESCRIPTION	PART NO.
1	1	MOUNTING PLATE	1177-1
2	1	BASE PLATE	1177-2
3	1	ALIGNMENT PLATE	1177-3
4	1	BORING HEAD, BORING ASSEMBLY	1177-4
5	1	LOCATING PLATE, BORING ASSEMBLY	1177-5
6	1	SUPPORT PLATE, BORING ASSEMBLY	1177-6
7	1	TOOL, PLATE, PRIMARY SIDE	1408-1
8	1	SHIELDED BEARING	8149
9	1	PULL OUT DOWEL, 1/2" x 3-1/2"	1685
10	9	3/8-16" x 1" SHCS	1686
11	4	1/4-20" x 1" SHCS	2133
12	4	DOWEL PIN, 1/4" x 3/4"	8093
13	2	BUSHING	1681
14	3	5/16-18" x 1" SHCS	2405
15	1	T-PIN, Ø3/8" SHANK	1687
16	2	TOOL BIT	1688
17	6	1/4-28" x 1/2" SET SCREW	1689
18	2	WASHER, 1/4", SAE	1683
19	1	5/16-18" x 1-3/4" SET SCREW	1200
20	1	5/16-18" JAM NUT	1222
21	1	1/4-20" x 1/2, BHCS	8090
22	3	DOWEL PIN 1/2" x 3-1/2"	1680
23	3	3/8" AN WASHER	1265
24	1	INSTRUCTION SHEET	1177-IS

# CASE BORING TOOLS

## UPGRADE KITS FOR YOUR CASE BORE TOOL

Below is an explanation of components that can be added to JIMS® case boring tools. JIMS® has provided you with the opportunity to save time and money by providing the following upgrade kits.



If you already have tool No. 1177 and would like to bore a 2006 thru 2007 Dyna™ and 2007 FLH, or a 2007 Softail® model, you need to obtain JIMS® tool No.1430. For more details see No.1177-IS instructions.

### PARTS AVAILABLE SEPARATELY

NO.	QTY.	DESCRIPTION	PART NO.
1	1	PRIMARY SIDE PLATE	1408-1
2	2	1/4" ALLEN SCREW	2133
3	1	INSTRUCTION SHEET	1177-IS



If you already have tool No.1409 and would like to bore Twin Cam® engine cases 1999-07 (all models) you will need to obtain JIMS® tool No.1431. For more details see No.1177-IS instructions.

### PARTS AVAILABLE SEPARATELY

NO.	QTY.	DESCRIPTION	PART NO.
1	1	BORING ASSY LOCATING PLATE ASSEMBLY	1177-5
2	1	DOWEL PIN	1680
3	1	PULL OUT DOWEL PIN	1685
4	1	PRIMARY SIDE PLATE	1408-1
5	1	ALIGNMENT PLATE	1177-3
6	3	3/8" ALLEN SCREW	1686
7	1	3/8" T-PIN	1687
8	2	1/4" ALLEN SCREW	2133
9	1	INSTRUCTION SHEET	1177-IS



If you already have tool No.1177 or No.1408, and would like to bore an EVO case 1984-99, you will need to obtain JIMS® tool No.1432. For more details see No. 1177-IS instructions.

### PARTS AVAILABLE SEPARATELY

NO.	QTY.	DESCRIPTION	PART NO.
1	1	BORING ASSEMBLY LOCATING PLATE	1409-2
2	1	DOWEL PIN	1680
3	1	PULL OUT DOWEL PIN	1685
4	1	EVO ALIGNMENT PLATE	1409-1
5	3	3/8" ALLEN SCREW	1306
6	1	INSTRUCTION SHEET	1177-IS



## JIMS® 120" TO 131" TWIN CAM® RACE CASE BORING TOOL

This tool allows you to bore a JIMS® 120 Race engine case for the installation of JIMS® 131" cylinder Kits. For more details see No.1177-IS instructions.

No.1400 - This Tool will bore all Alpha and JIMS® Evo motor mount Twin Cam® Race Cases.

13



## JIMS® 120" TO 131" TWIN CAM® RACE CASE BORING "ADAPTER HEAD KIT" TOOL

This tool allows you to bore a JIMS® 120 Race engine case for the installation of JIMS® 131" cylinder Kits. Explanation of components needed to bore JIMS® Twin Cam® Race Cases as follow: If you already have a JIMS® Tool No.1408 or No.1177 and wish to bore JIMS® Twin Cam Race Cases for 2006 to present Dyna® Cases and 2007 present FL touring Cases (both Models use the some cases) you will only need this new adapter "HEAD KIT" that is deigned with JIMS® cylinder bolt pattern. For more details see No.1177-IS instructions.

No.1433 - This Tool will bore all Alphas, and JIMS® Evo motor mount Twin Cam® Race Cases.

SEE JIMSUSA.COM FOR DETAILED INSTRUCTIONS

# CASE LAPPING TOOL

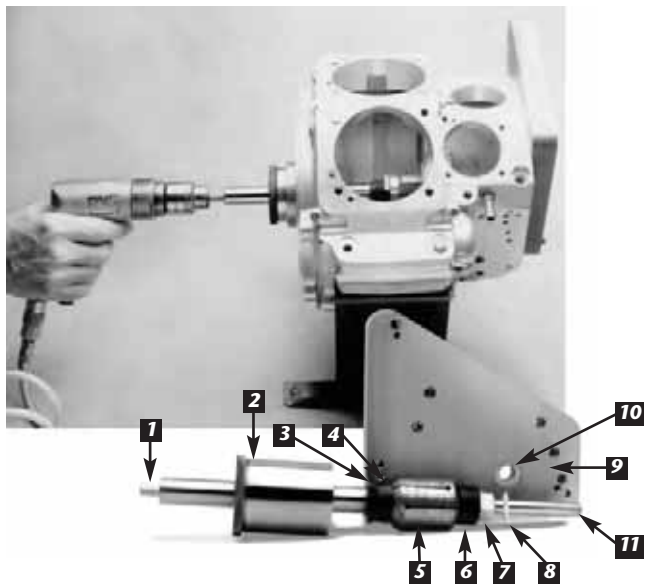

## BIG TWIN CASE LAP TOOL

Use on all 1958-present single cam.

**(NOTE: Includes aftermarket motors.)**

JIMS® goes the next step in case lapping with our pinion bearing race lap. This tool allows the engine builder to achieve the best of both worlds: removal of more material in less time with greater accuracy than a conventional lap.

JIMS® case lap—the first of its kind—is guided on both sides of the pinion bearing race. This additional support on the cam gear side of the bearing race is achieved by means of a bolt on base plate that precisely locates a drill bushing in which the lap turns. This base plate is located on the same engine case pins as the cam cover. The positioning of this drill bushing is held within .0002" to the engine case pins and within .0002" of case centerline.

Now, instead of guiding only from the left side with Timken® bearings, which are a floating fit, JIMS® case lap uses a special ground bearing sleeve to hold left side of lapping shaft without movement. Both ends of the lap are supported in precisely the same centerline as the flywheel assembly.

With this extremely rigid arrangement, it is possible to power the lap with a low speed drill motor without fear of chatter in the lapped bearing race. If a drill motor is not available, JIMS® lap can be powered by the conventional hand crank. Use JIMS® No.1710 to remove snap ring, a must on 1990-present H-D® cases.

**NOTE:** For 1958-69 early cases, use H-D® No.2341HW original cam cover screws.

All wear surfaces are hardened and ground tool steel for a lifetime of service. For more details see No.96710-IS instructions.

No.96710-TL - Case lap tool

### PARTS AVAILABLE SEPARATELY

NO.	QTY.	DESCRIPTION	PART NO.
1	1	MAIN BODY SHAFT	96710-TL-1
2	1	LEFT SLEEVE BEARING	96710-TL-2
3	1	LEFT LOCKING NUT	2266
4	1	LEFT COLLAR	96710-TL-4
5	1	LAP HEAD 1-3/4" O.D.	96710-TL-5
6	1	RIGHT COLLAR	96710-TL-6
7	1	NUT	1100
8	1	WASHER	2020
9	1	CAM COVER PLATE	96710-TL-11
10	1	DRILL BUSHING	2132
11	1	RETAINING RING	2134
12	7	SCREW	2135
13	1	INSTRUCTION SHEET	96710-IS



### CLOVER® OIL BASED LAPPING COMPOUND

Clover® is the brand used by H-D® enthusiasts for years. Use on valves for a good seal, also used with all JIMS® lapping tools. Available in 2 grits – for roughing-in and finish work. Use on JIMS tool No. 96710-TL and 96740-36.

No.1083 - 16 oz Coarse 220 Grit (Micron finish of 32).

No.1084 - 16 oz Fine 320 Grit (Micron finish of 16).

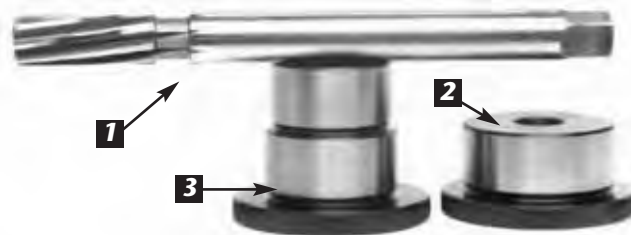

### PINION BUSHING LINE REAMER TOOL

Use to line pinion bushing in cam cover from right case race. The finest precision line reamer available. For more details see No.94805-IS instructions.

No.94805-57 - Use on all Big Twin 1954-99 single cam only, **(NOTE: Includes aftermarket motors, also XL 1957 to early 1984 idler gear bushing).**

### PARTS AVAILABLE SEPARATELY

NO.	QTY.	DESCRIPTION	PART NO.
1	1	REAM	94805-57-1
2	1	PILOT 1-3/4"	94805-57-2
3	1	PILOT 1-3/8" / 1-1/2"	94805-57-3
4	1	INSTRUCTION SHEET	94805-IS





## OUTER BALANCER BEARING INSTALLER & REMOVER TOOL

This tool removes and installs the outboard balancer bearing on the new 96" and 110" "B" Softail® engines chain guide support plate. For more details see No.957-IS instructions.

No.957 - Use on all Softails® 2007-present.

### PARTS AVAILABLE SEPARATELY

NO.	QTY.	DESCRIPTION	PART NO.
1	1	OUTER BEARING REMOVER/INSTALLER	961-1
2	1	OUTER SUPPORT	962
3	1	INSTALLER	961-2
4	1	WASHER	2038
5	1	BEARING	2010
6	1	SCREW	1221
7	1	NUT	2136
8	1	INSTRUCTION SHEET	957-IS



## BALANCER SHAFT BEARING REMOVER & INSTALLER

Performs like JIMS® other bearing removers by simplifying bearing removal. This tool will pull the bearings from the "B" motor case in one easy smooth motion preventing any damage to the bearing bores. The installing portion of this tool is designed to push on the outer diameter of bearings preventing any damage to the bearing or it's bore. Use installer portion of this tool with JIMS® tool No.33416-80. For more details see No.1167-IS instructions.

No.1167 - Use on all Twin Cam®2000-06 "B" model Softails®.

### PARTS AVAILABLE SEPARATELY

NO.	QTY.	DESCRIPTION	PART NO.
1	1	R/I BRIDGE	1167-1
2	1	INSTALLATION COLLAR	1167-2
3	1	PULLER	1167-3
4	1	BRASS WASHER	1099
5	1	NUT	1098
6	1	DOWEL PIN	95760-TB-1
7	1	INSTRUCTION SHEET	1167-IS

## BALANCER SHAFT RETENTION PINS

Use this tool to secure the engine balancers on Twin Cam "B" engines when servicing the flywheel assembly. This tool locks into the balancer's sprocket pin holes to prevent the balancer from turning out of sync with the flywheel. For more details see No.1163-IS instructions.

No.1163 - Use on all Twin Cam® 2000-present "B" model Softails®.

SEE JIMSUSA.COM FOR DETAILED INSTRUCTIONS



# TWIN CAM® BALANCER TOOLS



## BETA BALANCER INNER BEARING REMOVER/INSTALLER

### PARTS AVAILABLE SEPARATELY

NO.	QTY.	DESCRIPTION	PART NO.
1	1	BEARING PLATE PRESS	915-1
2	1	BEARING PRESS CUP	915-2
3	3	STANDOFF, BEARING PRESS	915-3
4	2	DRIVER	2190
5	1	SCREW	1024
6	1	BALANCER INSTALLER	962
7	1	INSTALLER COLLAR	1167-2
8	3	FLAT WASHER	2014
9	3	SCREW, SHCS	2016
10	1	O-RING FOR # 2190	2310

JIMS new tool will accurately and safely install or remove the inner balancer bearing

mounted in the left engine case. This tool is designed for early or late Beta cases, and all done on a work bench without using an arbor press. *For more details see No.915-IS instructions.*

No. 915 - Use on all Beta Twin Cam models 2000 to present.



## BALANCER SHAFT REMOVAL TOOL

This tool is designed to remove both front and rear counter-balancer shaft bearing assembly, from the left engine case on the new 96" and 110" Beta engines. *For more details see No.960-IS instructions.*

No.960 - Use on all Softails® 2007 to present.

### PARTS AVAILABLE SEPARATELY

NO.	QTY.	DESCRIPTION	PART NO.
1	1	REMOVER PLATE	960-1
2	1	REMOVER SCREW	960-2
3	3	STANDOFF	960-3
4	1	BEARING	2008
5	1	WASHER	2020
6	1	NUT	2032
7	1	INSTRUCTION SHEET	960-IS

NEW



## BETA ENGINE HYDRAULIC BALANCER RETAINER TOOL

Use these retainers to hold the hydraulic chain tensioners in place when repairing all Beta engines. These are a "must have" tool for proper assembly or disassembly of the beta engine balancer system. *For more details see No.779-IS instructions.*

No. 779 - Use on all Beta Twin Cam engines 2000 to present.



## BALANCER SHAFT ALIGNMENT TOOL

This tool is a must have for maintaining a long life of your balancer's drive chains and bearings. This tool will take all the guess work out of setting up your sprocket and chain alignment on a "B" Beta Twin Cam® Softail® engine. This tool has been improved to fit early or late balancer shafts. *For more details see No.952-IS instructions.*

No.952 - Use on all Twin Cam®2000 to present "B" model Softails®.

### PARTS AVAILABLE SEPARATELY

NO.	QTY.	DESCRIPTION	PART NO.
1	1	MAIN BODY	952-6
2	1	EARLY GAUGE	952-4
3	1	LATE GAUGE	952-5
4	1	THUMB SCREW	2022
5	1	SPRING	2021
6	1	RETAINING RING	2023
7	1	SHORT GUAGE SCREW	2297
8	1	LONG GUAGE SCREW	2024
9	1	INSTRUCTION SHEET	952-IS

SEE JIMSUSA.COM FOR DETAILED INSTRUCTIONS



## FLYWHEEL TRUING TOOL

Use this tool to fine tune flywheel assemblies when truing. Tool features both a flywheel expander, and contractor in one easy to use package. Made in America.

No.1417 - Use on all tapered shaft flywheel assemblies



## FLYWHEEL REBUILDING JIG

Clamps in vice to service and disassemble flywheels. Holds unit from turning when tightening shaft nuts.

- **EASY REMOVE AND REPLACE OF ALL SHAFTS.**
- **TWO 7/16" ALLEN SET SCREWS HOLD BOTTOM KEYED FLYWHEEL.**
- **CHANNEL IRON KEEPS UNKEYED TOP FLYWHEEL FROM MOVING.**
- **VERY LITTLE TRUING OF FLYWHEEL NEEDED.**

No.1071 - Use on all tapered shaft flywheel assemblies

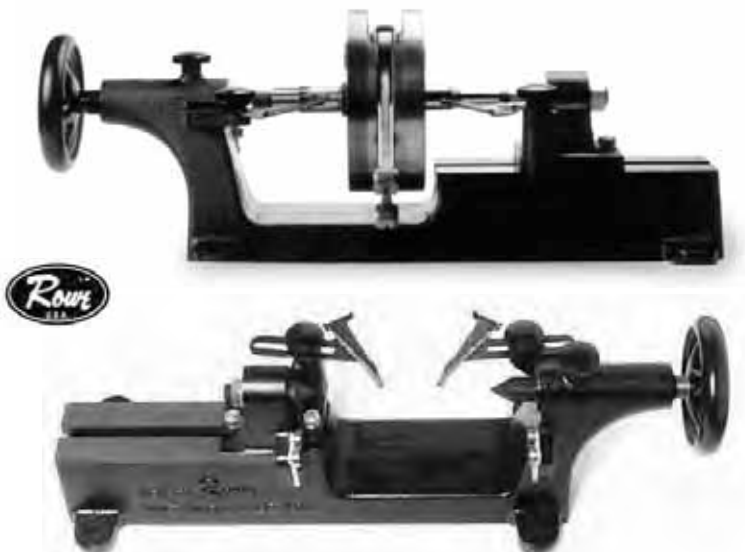

## FLYWHEEL TRUING STAND

10" right hand swing - 6" left hand swing -18" center to center capacity. Bearings center to center 8" - 19". Cast iron construction. Designed to true H-D® flywheels. Made by Rowe®.

No.1070



## SPROCKET SHAFT HOLDER

Use to hold the flywheel assembly in vise, with or without left case attached. For more details see No.1034-IS instructions.

No.1034 - Use on all Big Twin 1955-99 Pan, Shovel & EVO. Use on Twin Cam® 1999-05 FXD, 1999-06 FL and 2000-06 FXST & aftermarket motors.





## **TWIN CAM® ENGINE ROTATOR, FROM THE FLYWHEEL SPROCKET SHAFT**

Use this tool to rotate the flywheel / piston assembly, with the engine still in frame or on a bench. This tool is used to rotate the flywheel assembly when doing pushrod adjustments, when building big inch engines, checking operating clearances such as piston to piston, or valve to valve. Can also be used to hold the flywheel assembly from rotating when torquing the cam drive sprockets retention bolts. This tool has been manufactured with a long socket design making it easier to use without the use of a 1/2" drive extension on your 1/2" driver. For engine bench work we recommend the engine be bolted in a JIMS® engine stand. Use JIMS® No.1022 for 1999-06' FL's and FXD's. **CAUTION: NOT FOR USE WITH AIR OR ELECTRIC IMPACT, THIS TOOL IS ONLY GUARANTEED FOR USE WITH HAND DRIVERS, "NOT IMPACTS"**. For more details see No.975-IS instructions.

No.975 - Use on all 2006-present FXD's & 2007-present FXST's, & FL's.



## **BIG TWIN ENGINE ROTATOR, FROM THE FLYWHEEL SPROCKET SHAFT**

Use this tool to rotate the flywheel / piston assembly, with the engine still in frame or on a bench. This tool is used to rotate the flywheel assembly when doing pushrod adjustments, when building big inch engines, checking operating clearances such as piston to piston, or valve to valve. Can also be used to hold the flywheel assembly from rotating when torquing the cam drive sprocket retention bolts on Twin Cams® or pinion shaft nut on single cam models. This tool has been designed with a long socket design making it easier to use without the use of a 1/2" drive extension on your 1/2" driver. For engine bench work we recommend that the engine be bolted in a JIMS® engine stand. Use No. 1006T for Panhead, Shovelhead and EVO's. Use JIMS® No.1022 for 1999 to 06' FL's and FXD's. Use JIMS® No.902 for 2000 - present FXST's.

**CAUTION: NOT FOR USE WITH AIR OR ELECTRIC IMPACT, THIS TOOL IS ONLY GUARANTEED FOR USE WITH HAND DRIVERS, "NOT IMPACTS"**. For more details see No.976-IS instructions.

No.976 - Use on all Big Twins 1955-06 except 2006 FXD's. Use on 1999-05 FXD's.



## **SPROCKET SHAFT / FLYWHEEL HOLDER**

Used to hold flywheel assembly in vise, for assisting assembly or disassembly with or without left case attached. Can also be used to check case clearance on stroker flywheels. For more details see No.974-IS instructions.

No.974 - Use on all Twin Cam®, 2006-present FXD's or 2007-present FL's & FXST's.



## FLYWHEEL RUNOUT (TRUENESS) INSPECTION GAUGE

Check flywheel runout of the pinion shaft while assembled in engine case. Also checks the amount of gear lash on gear driven cams used in some twin cam engines. By using a JIMS tire rotator No. 936 you can remove most all of the stress being applied to the flywheel by not rotating the engine with the electric starter motor. For more details see No.785-IS instructions.



TESTING RUNOUT

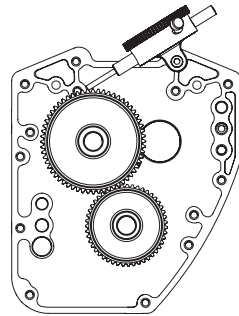

TESTING GEAR LASH

No. 785 - Use on 1970 to present Big Twin, Shovels, EVO and Twin



### PARTS AVAILABLE SEPARATELY

NO.	QTY.	DESCRIPTION	PART NO.
1	1	INDICATING PLATE	785-1
2	1	1" DIAL INDICATOR	940-4
3	1	THUMBSCREW	1391
4	1	THUMBSCREW	1392
5	1	SPACER	1085
6	1	SCREW	1122
7	1	INSTRUCTION SHEET	947-IS

## END PLAY GAUGE INDICATOR TOOL

Finally an indicator tool kit designed with the special H-D® thread pitch for mounting to cases for checking end play on engines or transmissions. Threads provided in both are 1/4"-20 and 5/16"-18 on the mounting rod. One example is shown in photo. Now you have a 360-degree indicator mount that can be used in any position for checking cam end play, rocker end play breather gear end play, flywheel run out, mainshaft, starter gear run out, and also shift drum end play. If mounted with the 5/16"-18 threaded mount you can mount to the primary side of the engine to check flywheel end play. The use of this tool is only limited to your imagination. For more details see No.940-IS instructions.

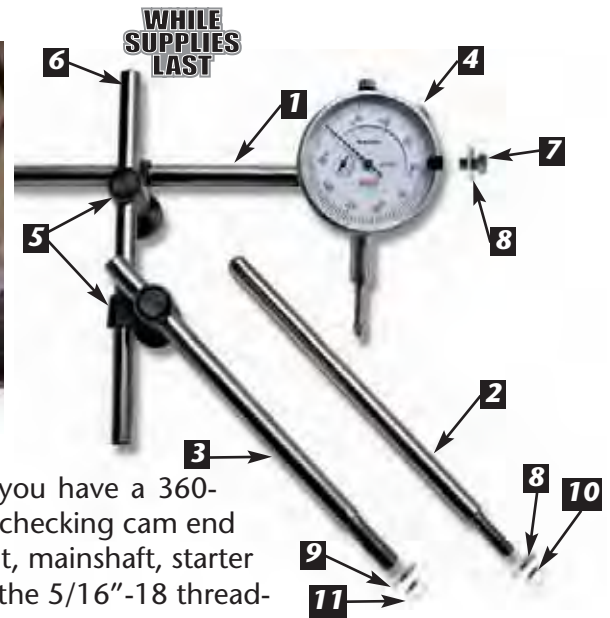

### PARTS AVAILABLE SEPARATELY

NO.	QTY	DESCRIPTION	PART NO.
1	1	I. D. THREADED ROD	940-1
2	1	1/4-20 THREADED ROD	940-2
3	1	5/16-18 THREADED ROD	940-3
4	1	INDICATOR GAUGE	940-4
5	2	SWIVEL CLAMP	940-5
6	2	ROD, NON - THREADED	940-6
7	1	SCREW, 1/4-20X5/8 SHCS	8362
8	2	WASHER, 1/4	1683
9	1	WASHER, 5/16	2014
10	1	NUT 1/4-20	2017
11	1	NUT 5/16-18	1222
12	1	INSTRUCTION SHEET	940-IS

No.940 - Use on all H-D® Big Twins & Sporters®.



## **MIGHTY BITE FLYWHEEL LOCK**

This tool holds the Twin Cam flywheels in place when performing service work to the connecting rods or pistons with the cylinders off the engine. Just take out the flywheel position sensor and install the "Mighty Bite" into the case. For more details see instructions No. 753-IS.

No. 753 - Use on all Twin Cam motors.



Endorsed By



## **FLYWHEEL SOCKETS**

Look no further for the best flywheel rebuilding sockets available. With a low profile, all sockets are just long enough to give 100% nut to socket contact and 100% drive end contact. Machined flat at the nut receiving end to eliminate rounding off the nut and greatly reducing the risk of bodily injury. Machined from solid steel 4130 chromium-molybdenum and heat treated to give a lifetime of service. *For more details see No.2358-IS instructions.*

### **USE ON ALL BIG TWIN 1954-EARLY 1981**

1-5/16" x 1/2" drive

No.1029-TU - Use to install or remove crank pin nut No.23966-54A.

### **USE ON ALL BIG TWIN LATE 1983-99 - SINGLE CAM ONLY**

1-1/2" x 1/2" drive

No.1030-TU - Use to install or remove crank pin nut No.23969-83.

### **USE ON ALL BIG TWIN LATE 1981-89**

1-1/4" x 1/2" drive

No.1031-TU - Use to install or remove pinion shaft nut No.24016-80.

### **USE ON ALL BIG TWIN 1972-99 - SINGLE CAM ONLY**

1-5/8" x 3/4" drive

No.1032-TU - Use to install or remove sprocket shaft nut No.24017-80.

### **USE ON ALL SPORTSTER® 1981-99 & BUELL® 1987-99**

1-3/8" x 1/2" drive

No.1033-TU - Use to install or remove crank pin nut No.23901-81.





## CRANKSHAFT BEARING TOOL

This quality tool is designed to remove and replace the right crankcase bearing. Precision made and piloted using Delrio, a non-marring material, to press bearing in and out straight with no damage to the case. *For more details see No.1275-IS instructions.*

No.1275 - Use on all 1999-02 Twin Cam® "Alpha" Only.

### PARTS AVAILABLE SEPARATELY

NO.	QTY.	DESCRIPTION	PART NO.
1	1	BEARING REMOVER / INSTALLER	1275-1
2	1	DRIVER / PILOT	1275A
3	1	INSTRUCTION SHEET	1275-IS

No.1672 - Use on all 2003-Present Twin Cam®  
Use on Alpha's left and right case bearings  
or on Beta's left case bearing. *For more  
details see No.1672-IS instructions.*

### PARTS AVAILABLE SEPARATELY

NO.	QTY.	DESCRIPTION	PART NO.
3	1	DRIVER / PILOT	1671
4	1	SUPPORT TUBE	1670
5	1	INSTRUCTION SHEET	1672-IS

## TWIN CAM® CRANKSHAFT BEARING INSTALLER AND REMOVER



Designed to protect expensive engine cases by using a specially designed support block to remove or install cam side crankshaft bearing. *For more details see No.1146-IS instructions.*

No.1146 - Use on all 2000-present Twin Cam® "Beta" Softails®.

### PARTS AVAILABLE SEPARATELY

NO.	QTY.	DESCRIPTION	PART NO.
1	1	INSTALLER/REMOVER	1146-4
2	1	PILOT DRIVER	1146-3
3	2	O-RING	1180
4	1	INSTRUCTION SHEET	1146-IS



## CRANKSHAFT BUSHING TOOL

This tool will remove and install crankshaft bushings in the support plate on a Twin Cam®. This tool is piloted for accurate operation. *For more details see No.1281-IS instructions.*

No.1281 - Use on all Twin Cam®.

### PARTS AVAILABLE SEPARATELY

NO.	QTY.	DESCRIPTION	PART NO.
1	1	TOOL, SUPPORT BUSHING	1281-1
2	1	TOOL, DRIVER BUSHING	1281-2
3	1	DOWEL PIN - NOT SHOWN	1993
4	1	INSTRUCTION SHEET	1281-IS

# SPROCKET SHAFT BEARING TOOLS

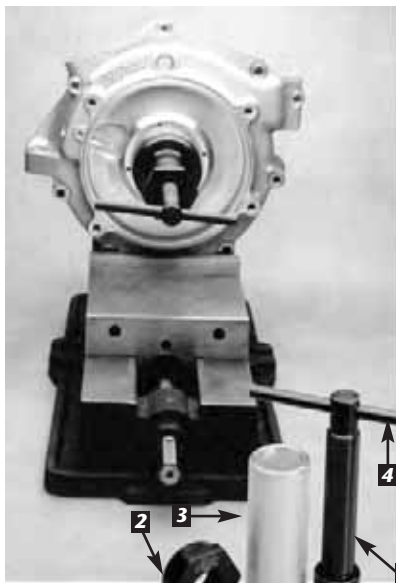

**IMPORTANT NOTE:**  
You must use a 94660-37A socket with the 97225-55 and the 97081-54 tool - Sold separately on page 194.

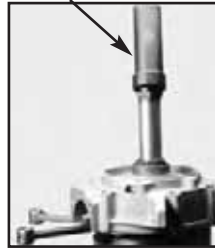

Designed to give the best control on the torque of bearing pack for checking bearing end play. Torque nut with JIMS® tool No.94660-37A for consistent professional results.

## BIG TWIN SPROCKET SHAFT BEARING INSTALLATION TOOL

Use to install flywheel assembly into left crankcase Timken® bearing. For more details see No.97225-IS instructions.

No.97225-55 - Use on all Big Twin 1955-2002.  
(NOTE: Includes JIMS® 120", 131" & 135" Twin Cam® and other aftermarket motors.)

### PARTS AVAILABLE SEPARATELY

NO.	QTY.	DESCRIPTION	PART NO.
1	1	MAIN BODY	97225-55-1
2	1	NUT/HANDLE ASSEMBLY	1026B
3	1	SLIDER	97225-55-3
4	1	LONG HANDLE	1028
5	1	BEARING	2001
6	2	WASHER	2002
7	1	INSTRUCTION SHEET	97225-IS



## SPORTSTER® SPROCKET SHAFT BEARING INSTALLATION TOOL

Use to install flywheel assembly into left crankcase Timken® bearing. Use with No. 37047-91-5 sleeve and No. 37047-91-6 for 1977-2003. For more details see No.97081-IS instructions.

No.97081-54 - Use on all Sportsters® and K 1952-76.

### PARTS AVAILABLE SEPARATELY

NO.	QTY.	DESCRIPTION	PART NO.
1	1	MAIN BODY	97081-54-1
2	1	NUT AND ASSEMBLY	1026B
3	1	SLIDER	97081-54-3
4	1	LONG HANDLE	1028
5	1	BEARING	2001
6	2	WASHER	2002
6	1	INSTRUCTION SHEET	97081-IS

## SPROCKET SHAFT BEARING INSTALLATION TOOL

Use to install crank shaft assembly into crankcase Timken® bearings. Use with No.97081-54. Use tool No.37047-91-5 to install the bearing until tool runs out of threads, then install No.37047-91-6 to push the bearing on the rest of the way. For more details see No.37047-IS instructions.

No.37047-91-6 - Use on all Sportster® 1977-03.  
Use on all Buell® 1987-03.  
2.500" long.

No.37047-91-5 - Use on all Sportster® 1977-03.  
Use on all Buell® 1987-03.  
2.060" long.



SEE JIMSUSA.COM FOR DETAILED INSTRUCTIONS



## CRANKSHAFT GUIDE

This tool will spread crankcase pinion bearing rollers while reassembling right side engine case on to flywheel assembly. For more details see No.1288-IS instructions.

No.1288 - Use on all Twin Cam®, "Alpha" and "Beta" 1999-present, and XB9R/XB9S 2003-present.



## TIMKEN® BEARING OR RACE INSTALLER ADAPTER KIT

This tool will upgrade your earlier JIMS® No.97225-55 bearing installer tool to work on the latest fine spline Twin Cam® sprocket shafts. This tool is designed to install either H-D® No.9028 Timken® bearing or the roller bearing race included with H-D® No.24004-03. Bearing assembly onto the sprocket shaft as shown in the above photos. *For more details see No.973-IS instructions.*

No.973 - *Use on all Big Twins 2006-present FXD's or 2007-present FXST's & FL's. Also use on JIMS® 120", 131", or 135" motors.*

### PARTS AVAILABLE SEPARATELY

NO.	QTY.	DESCRIPTION	PART NO.
1	1	ADAPTER	973-1
2	1	SLIDER	973-2
3	1	INSTRUCTION SHEET	973-IS

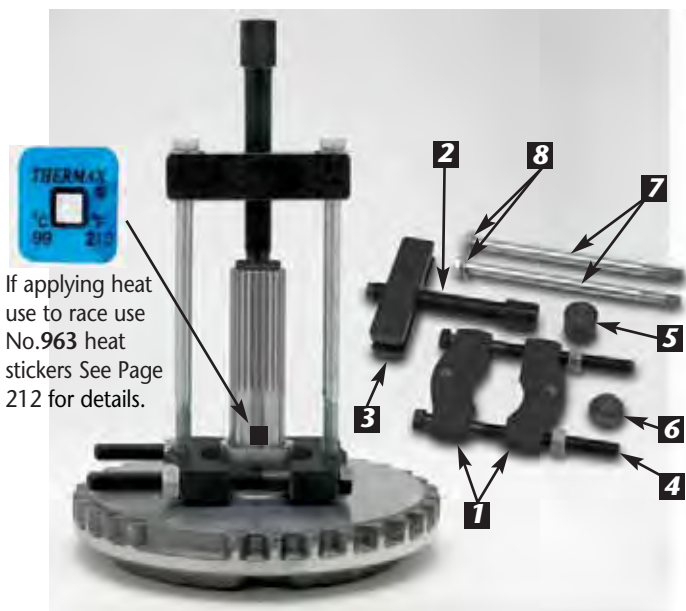

## BEARING AND RACE PULLER TOOL

This tool has been designed to remove the flywheel sprocket shaft inner bearing with the supplied JIMS® T-bar and hardware. If heat is needed to remove race see tool No. 899 on page 212. *For more details see No.963-IS instructions.*

No.963 - *Use on all Twin Cams® 2003-present. Use to remove Timken® bearing (H-D® No.9028) or No.9029 on Big Twins, 1955 Panhead to present Twin Cam®, including JIMS® 120", 131", or 135" engines.*

*Use to remove the flywheel sprocket shaft inner bearing race or the Timken® bearing. Also removes pinion shaft inner bearing race on Sportster® 1954-present, including all Buell's to present.*

*Use to correctly remove press fit transmission gears and bearings from input and output shafts on all V-Rod® models 2002-present.*

### PARTS AVAILABLE SEPARATELY

NO.	QTY.	DESCRIPTION	PART NO.
1	2	WEDGE PLATE	963-1
2	1	SCREW	1024
3	3	PULLER BAR	2013
4	2	WEDGE PLATE HARDWARE KIT	963-2
5	1	HARDENED CAP, EARLY	1048-1
6	1	HARDENED TIP, LATE	995-3
7	2	SCREW	2030
8	2	WASHER	2031
9	1	INSTRUCTION SHEET	963-IS



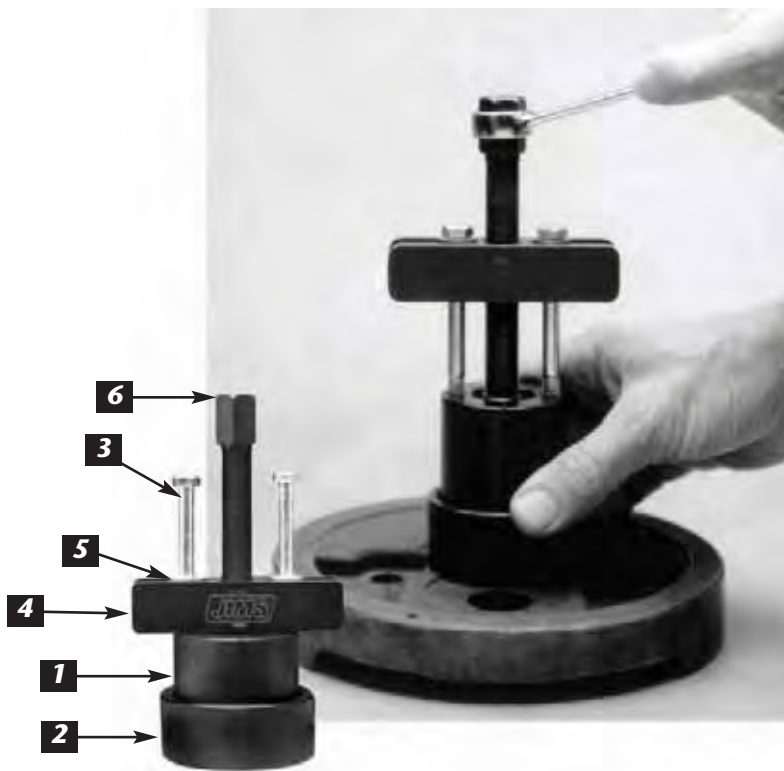

## EARLY BIG TWIN TIMKEN® BEARING REMOVER

Use to remove Timken® bearing from sprocket shaft without removing shaft from flywheels. (Optional: To protect the end on the sprocket shaft use hard end cap No.1048.) For more details see No.2330-IS instructions.

No.1045-TU - Use on all Big Twin 1955-85 stock flywheels. Use on Big Twin 1955-02 after-market flywheels.

## SPORTSTER® TIMKEN® BEARING PULLER

Tool easily removes the inner Timken® bearing from sprocket shaft without removing the shaft from flywheels. For more details see No.2305-IS instructions.

No.2305 - Use on all Sportster® 1957-76.

### PARTS AVAILABLE SEPARATELY

NO.	QTY.	DESCRIPTION	PART NO.
1	2	BEARING HOLDER SIDES	2305-1
2	1	RING	1044-TU-2
3	2	BOLT	2007
4	1	PULLER BAR	2013
5	2	FLAT WASHER	2014
6	1	SCREW	1024
7	1	INSTRUCTION SHEET	2305-IS

## SPORTSTER® TIMKEN® BEARING REMOVER

Use to remove Timken® bearing from sprocket shaft without removing shaft from flywheels. For more details see No.1044-IS instructions.

No.1044-TU - Use on all Sportster® 1977-03.

Use on all Buell® 1987-03.

### PARTS AVAILABLE SEPARATELY

NO.	QTY.	DESCRIPTION	PART NO.
1	2	BEARING HOLDER	1044-TU-1
2	1	RING	1044-TU-2
3	2	BOLT	2007
4	1	PULLER BAR	2013
5	2	FLAT WASHER	2014
6	1	SCREW	1024
7	1	INSTRUCTION SHEET	1044-IS

### PARTS AVAILABLE SEPARATELY

NO.	QTY.	DESCRIPTION	PART NO.
1	2	BEARING HOLDER SIDES	1045-TU-1
2	1	RING	1045-TU-2
3	2	BOLT	2012
4	1	PULLER BAR	2013
5	2	FLAT WASHER	2014
6	1	SCREW	1024
7	1	INSTRUCTION SHEET	2330-IS

## BIG TWIN TIMKEN® BEARING REMOVER

This tool will remove the sprocket shaft Timken® bearing on late Big Twins, 1986-present, with an integral sprocket shaft. A specialized tool that does the job better than anything else on the market. (Optional: To protect the end on the sprocket shaft use hard end cap No.1048.) For more details see No.1709-IS instructions.

No.1709 - Use on all Big Twin 1955-02.

(NOTE: Includes JIMS® Twin Cam®.)

### PARTS AVAILABLE SEPARATELY

NO.	QTY.	DESCRIPTION	PART NO.
1	2	BEARING HOLDER	1709-1
2	1	RING	1045-TU-2
3	2	BOLT	1716
4	1	PULLER BAR	2013
5	2	FLAT WASHER	2014
6	1	SCREW	1024
7	1	INSTRUCTION SHEET	1709-IS

# SPROCKET SHAFT BEARING TOOLS



## TOOL DRIVER SPACER

Use with driver tools No.33071-73, No.94547-80A, No.33416-80, and 2232. The effectiveness of any bearing race remover tool is dependent on the ability to grip the race. This spacer applies outward force on the bearing race tool to grip better, allowing easier removal of race. *For more details see No.2388-IS instructions.*

No.2388 - Use on all bearing race tools.

JIMS No.2256-1 DRIVER NOT INCLUDED



## SPROCKET SHAFT SEAL INSTALLER

Use this kit to install the sprocket shaft seal H-D® No.35151-74A to the proper depth, and also for holding the seal perfectly square, for a no leak fit. Driver handle sold separately, order handle No.2256-1 (See below).

No.2324 - Use on all Sportster® 1974-2003 & Buell® 1987-02.



## DRIVER HANDLE

No.2256-1 - Use with seal driver No.2324. For more details see No.2324-IS instructions.



## SPROCKET SHAFT BEARING RACE TOOL

Use to remove and install Timken® bearing race from motor case. Use with Handle No. 33416-80 below. *For more details see No.94547-IS instructions.*

No.94547-80A - Use on all Big Twin 1969-2002. **(NOTE:** Includes Twin Cam and aftermarket motors.)



## SPROCKET SHAFT BEARING RACE TOOL

Use to remove and install Timken® bearing race from motor case. Use with Handle No.33416-80 below. Instruction Sheet No.94547-IS. *For more details see No.94547-IS instructions.*

No.94547-80B - Use on all Sportster® 1977-2003. Use on Buell® 1987-2003.



## RACE & BEARING INSTALL TOOL HANDLE

*For more details see No.34416-IS instructions.*

No.33416-80 - Use with No's. 33071-73, 34810-84, 94547-80A & B, 97272-60, 2232, and 97273-60. Approximately 12" long.

### PARTS AVAILABLE SEPARATELY

NO.	QTY.	DESCRIPTION	PART NO.
1	1	O-RING	2310
2	1	INSTRUCTION SHEET	33416-IS



## TIMKEN® BEARING RACE INSTALLER

Use to install bearing races in left crankcase. Use this precision tool to press in bearing races straight time after time (a must for the later engine case). For removal of Big Twin races, in 1969-02' cases, use JIMS® tool No.94547-80A. See previous page. For more details see No.2246-IS instructions.

No.2246 - Use on all Big Twin 1969-02. (**NOTE:** Includes Twin Cam® and aftermarket motors.) Use on all Sportster® 1977-03. Use on all Buell® 1987-02.

### PARTS AVAILABLE SEPARATELY

NO.	QTY.	DESCRIPTION	PART NO.
1	1	TOOL BASE	2246-1
2	1	BIG TWIN PLUG	2246-2
3	1	XL PLUG	2246-3
4	2	DOWEL PIN	1003-3
5	1	INSTRUCTION SHEET	2246-IS



## SNAP RING INSTALLER & REMOVER TOOL

A JIMS® exclusive! This tool will remove and install the Timken® Bearing outer race snap ring, without damage to case. A must for replacing rings in cases without inserts. Now you can replace snap ring in Big Twin cases without fear of gouging the aluminum on 1990-present cases. Instruction sheet No.1710-IS. Use heavy duty round tipped snap ring plier. For more details see No.1710-IS instructions.

No.1710 - Use on all Big Twin 1969-2002. (Note: Includes Twin Cam® and aftermarket motors.)

## TIMKEN® BEARING SIMULATOR

This tool is designed to allow quick and easy removal and replacement, of flywheel assembly in the left side crankcase when checking rod to case, piston to flywheel, or cylinder to flywheel clearances. Made from black Delrio plastic, will not mar bearing races. For more details see No.1745-IS instructions.

No.1745 - Use on all Big Twin 1970-02. (Note: Includes Twin Cam® and aftermarket motors.)

### PARTS AVAILABLE SEPARATELY

NO.	QTY.	DESCRIPTION	PART NO.
1	1	NUT	24003-55
2	1	SIMULATOR	1745-1
3	1	INSTRUCTION SHEET	1745-IS

Endorsed By







## BETA CASE SUPPORT BLOCK TOOL

The new Beta Case Support Block Tool, JIMS No. 916 was submitted to JIMS as a tool idea from a MMI instructor Derek Beck on our "JIMS Tool Submission Program". This innovative tool is designed to protect the left engine case while servicing the inner balancer bearings or performing other general engine work. These blocks attach to the outer side of the engine case underneath the balancer bearing pads surface. The blocks are made of aluminum and have an inserted Delrio pad that rest against the case to prevent marring. The blocks properly support the case, keeping it on a level plane when using a press for bearing service work. These tool blocks also keep the case level when using JIMS tool No.915 to remove the balancer bearings without an arbor press. For more details see No. 916-IS Instructions.

No. 916 - Use on all Beta Softail® Twin Cam models 2000 to present.



## MOTOR SPROCKET SHAFT SEAL INSTALL TOOL

Use to press oil seal over sprocket shaft into case. Use with No.97225-55. For more details see No.39361-IS instructions.

No.39361-69 - Use on all Big Twin 1969-present. (NOTE: Includes Twin Cam® and aftermarket motors.)



## SPROCKET SHAFT BEARING NUT WRENCH

Use to install and remove bearing nut. For more details see No.97235-IS instructions.

No.97235-55B - Use on all Big Twin 1955-68.

### PARTS AVAILABLE SEPARATELY

NO.	QTY.	DESCRIPTION	PART NO.
1	2	PINS	2141
2	1	INSTRUCTION SHEET	97235-IS

# LEFT CASE TOOLS

## LATE MODEL T/C CASE SPLITTER TOOL

Use this tool to "break" the case sealant by pushing apart both case halves. Bolt this tool to the primary mounting holes with supplied hardware. Hand thread-in pushing screw (do not use impact tools). Flywheels will be pushed from the left case. For more details see No.995-IS instructions.

No.995 - Use on all Twin Cam®, 2006 to present Dyna™ and 2007 to present FL & FXST.

### PARTS AVAILABLE SEPARATELY

NO.	QTY.	DESCRIPTION	PART NO.
1	1	SCREW	1024
2	1	SCREW, 5/16"	2016
3	1	WASHER, 5/16" I.D.	2014
4	1	PLATE	995-2
5	3	SCREW, 1/4"	1122
6	3	WASHER, 1/4" I.D.	1683
7	1	SHAFT PLUG	995-3
8	1	INSTRUCTION SHEET	995-IS



## CRANK DISASSEMBLY REMOVING TOOL

Use to press flywheels from cases (Will also press cases apart and break sealant bond). Some case pressing will require a hard cap. For more details see No. 1047-IS Instructions.

No.1047-TP - Use 1955 to 2006 Big Twins except 2006 Dyna. Works on most aftermarket engines.

On Twin Cam® "B Motor" - This tool can only be used for removing the flywheel from the left case.

### PARTS AVAILABLE SEPARATELY

NO.	QTY.	DESCRIPTION	PART NO.
1	1	SCREW	1024
2	4	BOLT	2007
3	4	WASHER	2014
4	1	INSTRUCTION SHEET	1047-IS



If applying heat to case use No.899 heat stickers See Page 212.

Endorsed By



## HARD CAP

Use to protect sprocket shaft when using JIMS® tool No.1047-TP, or a press. Instruction Sheet No.1048-IS. For more details see No. 1048-IS Instructions.

No.1048 - Use 1955 to 2006 Big Twins except 2006 Dyna. Works on most aftermarket engines.



# PINION GEAR TOOLS



## PINION GEAR NUT SOCKET

Use to remove or secure pinion gear nut to pinion gear shaft. 1/2" Drive. Use with JIMS® tool No.2237 lock-er, see below. For more details see No.94555-55A-IS instructions.

No.94555-55A - Use on all Big Twin 1954-92.

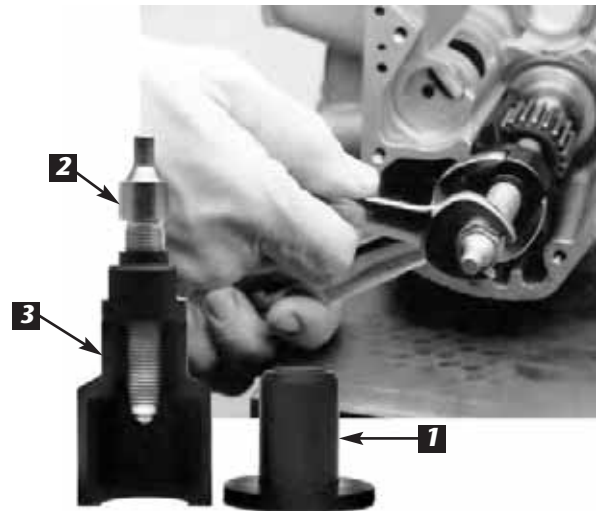

## PINION GEAR INSTALLER & PULLER

Use to install pressed on splined pinion gears on Big Twin 1939-53. Use to remove pinion gear on Big Twin 1939-89 and Sportsters® 1957-76. For more details see No.96830-IS instructions.

No.96830-51 - Use on all Big Twin 1939-89 and Sportsters® 1957-76.

### PARTS AVAILABLE SEPARATELY

NO.	QTY.	DESCRIPTION	PART NO.
1	1	COLLAR	96830-51-1
2	1	SCREW	96830-51-2
3	1	PULLER	96830-51-3
4	1	INSTRUCTION SHEET	96830-IS



## BIG TWIN PINION GEAR LOCKER TOOL

Use to lock pinion gear, necessary to torque the pinion nut. Tool is simple to use, just align underneath gear and screw into case. Use JIMS® tool No.94555-55A to tighten pinion nut. For more details see No.2237-IS instructions.

No.2237 - Use on Big Twin 1954-present single cam only. (NOTE: Includes aftermarket motors.)

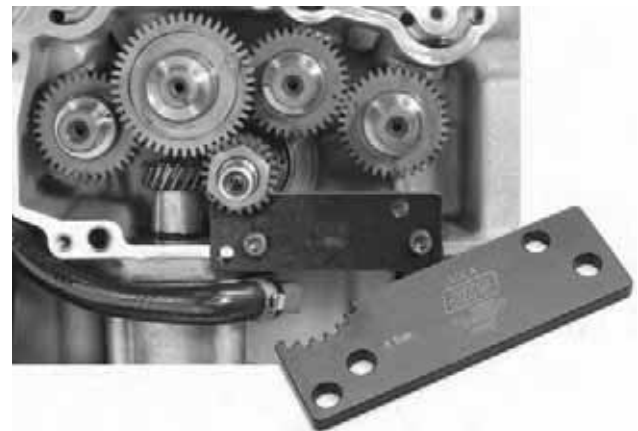

## XL & BUELL® PINION GEAR LOCKER TOOL

Use tool to lock pinion gear when torquing the pinion nut. Tool is simple to use, just align underneath gear and screw into case. For more details see No.1665-IS instructions.

No.1665 - Use on all Sportster® and Buell® 2000 Present, except 1125R.

No.1666 - Use on all Sportster® and Buell® 1991-99.





**TWIN CAM® OIL PUMP  
ALIGNMENT SCREWS**   
1/4"-20 threads

Use to align Twin Cam® oil pump to cam support plate. Helps reduce oil scavenging problems associated with oil pump misalignment. Two alignment screws required. *For more details see No.33443-IS instructions.*

No.33443-84 - Use on all Twin Cam® (requires two).



**NEW**  **ENGINE DIPSTICK SOCKET**

Are you tired of burning your hand while you check the oil level on your Bagger or Dyna? If so, you're not alone, Gary Smith has teamed-up with JIMS® to develop this Engine Dipstick Socket. This ingenious new tool, Patent #D630092, allows riders and mechanics alike to quickly, and safely remove the engine oil level dipstick that lies precariously close to a scorching hot exhaust pipe. The Dipstick Socket not only protects your hands from the heat, but aids riders with limited hand strength in easily checking their oil level. Features include a square hole for 3/8" ratchet fitment, 7/8" hex for wrench fitment, and a cutout for clearance around the exhaust pipe. This American tool is made of non-marring Delrio ensuring strength, durability, and heat resistance.

No.759 - Use on all Touring Models 2007 - 2011, Dyna 2006 - 2011. Use on all Screamin' Eagle Touring Models 2007 - 2012. All with the O.E.M. original dipsticks on above models.

**OIL PUMP SEAL INSTALLER**

Easily installs oil pump seal perfectly below gear surface for a no leak fit. *For more details see No.1053-IS instructions.*

No.1053 - Use on all aluminum Big Twin pumps single cam only. (**NOTE:** Includes aftermarket motors.)

**PARTS AVAILABLE SEPARATELY**

NO.	QTY.	DESCRIPTION	PART NO.
1	1	MANDREL, FEMALE	1053-1
2	1	MANDREL, MALE	1053-2
3	1	INSTRUCTION SHEET	1053-IS

SEE [JIMSUSA.COM](http://JIMSUSA.COM) FOR DETAILED INSTRUCTIONS





## OIL PUMP SNAP RING INSTALLER

Easily install outer snap ring on oil pump shaft, without over stretching the ring. Just apply oil to ring expander, slip ring up to the big end of ring expander, hold up to the end of the shaft, then push ring onto the shaft with sleeve. *For more details see No.1052-IS instructions.*

No.1052 - Use on all Big Twin oil pumps single cam only. **(NOTE: Includes aftermarket motors.)**

### PARTS AVAILABLE SEPARATELY

NO.	QTY.	DESCRIPTION	PART NO.
1	1	RING EXPANDER	1052-1
2	1	SLEEVE	1052-2
3	1	INSTRUCTION SHEET	1052-IS



## TAPPET OIL FILTER SCREW PLUG TOOL

Use to remove tappet oil filter screen plug without removing exhaust pipes. *For more details see No.2233-IS instructions.*

No.2233 - Use on all Big Twins single cam.



### PINCER CLIPS AVAILABLE

#### STEEL O-CLIP PINCER TOOL

Pincer tool is used for installation of steel O-Clips. Steel O-Clips are used for crimping vinyl or Tygon fuel line to fittings. Pincer clips sold separately.

No.1171 - Pincer Tool

No.1171-1 - 7/16" O-clips (for 1/4" hose) 10-PK

No.1171-2 - 1/2" O-clips (for 5/16" hose) 10-PK

No.1171-3 - 9/16" O-clips (for 3/8" hose) 10-PK

**NEW**



## SLIM JIM OIL FILTER WRENCH

This is the industries slimmest filter wrench allowing more clearance to remove the oil filter, especially around oil coolers and crank position sensors. The tool has a 3/8" drive receiver for an extension tool.

No. 941 – Use on all 14 flute oil filters for H-D's.



## 76mm OIL FILTER CAP WRENCH

A perfect fit for all 76mm oil filters with 14 flute ends. The cup design allows easy filter removal or installation, even in tight locations. Use with 3/8" square drive. **Will not work on Twin Cam® Alpha engines.**

No.1769 - Use on all Big Twins, XL's & all Buells®, and all oil filters requiring a 76mm, fourteen flute wrench.

18



## OIL FILTER CUTTING STAND

This stand makes the task of cutting open your oil filter easy. No longer will that slippery filter drop while trying to cut it open. This stand can be mounted to a bench or used in a vice. The u-bolt quickly tightens the filter in place with the wing nuts provided. Use JIMS® No. 935 oil filter cutter shown on right when using this tool. *For more details see No.934-IS instructions.*

No.934 - Fits all common O.E.M. H-D® spin-on oil filters.



## OIL FILTER CUTTER

Troubleshooting your oil management system requires looking at the oil filter. Use this tool to inspect for any damaging particles that may be trapped in the filter. This tool locks down the filter for a clean cut around the filter base by rotating the filter. Use this tool with JIMS® No. 934 oil filter cutting stand along with a common vise. See left side. Will fit filters up to 5-1/2" diameter.

No.935 - Fits spin on style oil filters to 5-1/2" diameter.



# PRIMARY DRIVE TOOLS



## PRIMARY LOCKING BARS

Use to lock primary for service work.

- No.2312 - Use on all 2007 to present FL. For more details see No.2312-IS instructions.
- No.2315 - Use on all 2006 to present Dyna™ and 2007 FLHT & FXST. Do not use Tool No.2234 for 2006 Dyna™ primary service work. For more details see No.2384-IS instructions.
- No.2316 - Use on all 4-Speed Big Twins and 5-Speed EVO FXST. Use on Twin Cam® 1999-2005 FXD, 1999-2006 FL and 2000-2006 FXST. For more details see No.2384-IS instructions.
- No.2317 - Use on all 5-Speed EVO or Shovel FXR, FLT & FLHT. For more details see No.2384-IS instructions.
- No.2318 - Use on all 883 Sportster. For more details see No.2318-IS instructions.

## ALL PRIMARY DRIVE LOCKING TOOL



Use on all primaries between front primary chain and motor sprocket. Made out of Black Delrio. For more details see No.2234-IS instructions.  
No.2234 - Locking Tool



## GASKET LOCATOR TOOL

This tool will assist you in aligning the gaskets to avoid misalignment and oil leaks. Primary cover, cam cover, and transmission end cover gaskets are just a few of the possible applications. For more details see No.968-IS instructions.

No.968 - Use on all models with 1/4"-20 threaded gasket surface mounting holes. 3 piece set.



## COMPENSATING SPROCKET SHAFT NUT WRENCH

Use to remove & install compensating nut. For more details see No.94557-IS instructions.

No.94557-55A - Use on all Big Twin and Sportster® 1955-70. 1/2" Drive.

### PARTS AVAILABLE SEPARATELY

NO.	QTY.	DESCRIPTION	PART NO.
1	2	PINS	2015
2	1	INSTRUCTION SHEET	94557-IS



## XL PRIMARY COVER INSPECTION PLUG TOOL

This tool is used to remove and install the OEM style primary cover clutch adjuster access plug and filler plug without distorting the plug's slot.

No.1168 - Use on all 1954 - 1990 Sportsters® & K-Models with aluminum primary covers.

# INNER & OUTER PRIMARY COVER TOOLS

## INNER PRIMARY COVER BEARING AND SEAL INSTALLER/REMOVER TOOL



Designed to safely remove and install the inner primary bearing, (H-D® No.9135) without any damage to the new bearing. This is done by pushing on the outer perimeter of the bearing. Also removes and installs inner primary seal, (H-D® No.12052A). This is the bearing and seal that the transmission mainshaft passes through. *For more details see No.967-IS instructions.*

No.967 - Use on all Late 1984-06 FXST, 1985-06 FL, 1985-06 FXR, FXD.

### PARTS AVAILABLE SEPARATELY

NO.	QTY.	DESCRIPTION	PART NO.
1	1	SEAL REMOVER	967-1
2	1	SEAL INSTALLER	967-2
3	1	BACKING PLATE	967-3
4	1	ALLEN SCREW	1211
5	2	WASHER	2038
6	1	BEARING	2010
7	1	NUT	2136
8	1	INSTRUCTION SHEET	967-IS



## STARTER JACKSHAFT SEAL INSTALLER TOOL

This tool is designed to easily align and install the starter jackshaft seal (H-D® No.12066) without distorting or damaging the seal. This seal is located in the upper part of the inner primary of Big Twins. *For more details see No.966-IS instructions.*

No.966 - Use on all Big Twins 1994-06 except 06' Dyna.

### PARTS AVAILABLE SEPARATELY

NO.	QTY.	DESCRIPTION	PART NO.
1	1	SEAL REMOVER	966-1
2	1	SEAL INSTALLER	966-2
3	1	BACKING PLATE	966-3
4	1	ALLEN SCREW, 3/8"-16 X 2	1696
5	2	WASHER, 3/8" SAE	2031
6	1	NUT, 3/8"-16	2035
7	1	INSTRUCTION SHEET	966-IS



## OUTER PRIMARY COVER STARTER SHAFT BEARING REMOVER TOOL

Bearing can easily be removed, even if cover has been chromed with bearing installed. *For more details see No.2235-IS instructions. Note: This tool will also remove the H-D® 35961-52 bearing in countershaft gear (late) 4 speed Big Twin, as well as 4-speed Sportster® clutch gear.*

No.2235 - Use on all Big Twin, Sportster®, and covers that use bearing No.9063.

### PARTS AVAILABLE SEPARATELY

NO.	QTY.	DESCRIPTION	PART NO.
1	1	PIN	95670-TB-1
2	1	NUT	1098
3	1	BRASS WASHER	1099
4	1	BODY	2235-4
5	1	PULLER	2235-5
6	1	INSTRUCTION SHEET	2235-IS

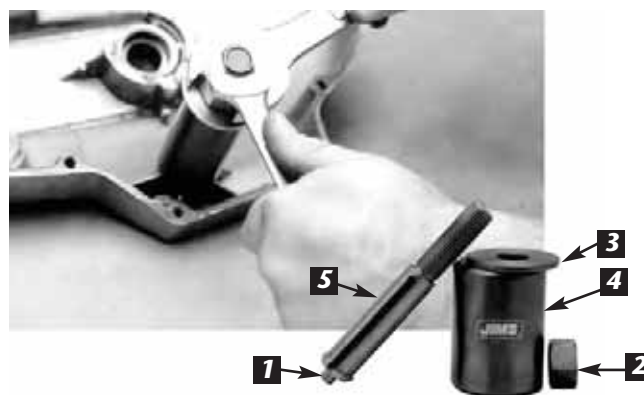





## CLUTCH ASSEMBLY SERVICE TOOL FOR BIG TWINS

This tool will safely disassemble and assemble the clutch shell assembly. Easily removes and installs the clutch hub from its bearing. Safely removes and installs the clutch shell ball bearing (H-D® No.37906-90) without any damage to the new bearing. This is done by pushing on the outer perimeter of bearing. For more details see No.971-IS instructions.

No.971 - Use on all Big Twins 1990-2006.

### PARTS AVAILABLE SEPARATELY

NO.	QTY.	DESCRIPTION	PART NO.
1	1	CLUTCH BASKET BEARING R/I	971-3
2	1	CLUTCH HUB R/I	971-4
3	1	BEARING INSTALLER ASSEMBLY	971-5
4	1	BASKET PEDESTAL	971-6
5	1	INSTRUCTION SHEET	971-IS



## STARTER RING GEAR RIVET FIXTURE TOOL



This tool is designed to remove the starter ring gear rivets from Big Twin clutch shells to install JIMS® No. 639 and 640 or equivalent performance starter ring gears. For more details see No.965-IS instructions.

No.965 - Use on all 1990-06 FL, FXST and 1990-05 FXR, and FXD.

### PARTS AVAILABLE SEPARATELY

NO.	QTY.	DESCRIPTION	PART NO.
1	1	DRILL FIXTURE	965-1
2	1	RIVET REMOVER FIXTURE	965-2
3	1	RIVET REMOVER	965-3
4	2	SCREW	2405
5	1	DRILL	2223
6	1	INSTRUCTION SHEET	965-IS



Endorsed By



## CLUTCH LOCK PLATE

Use to lock clutch shell to clutch hub, for removing or installing clutch hub nut. Use with JIMS® tool No.2316 primary locking bar. For more details see No.2245-IS instructions.

No.2245 - Use on all Big Twin 1941-84.



# CLUTCH SPRING TOOLS

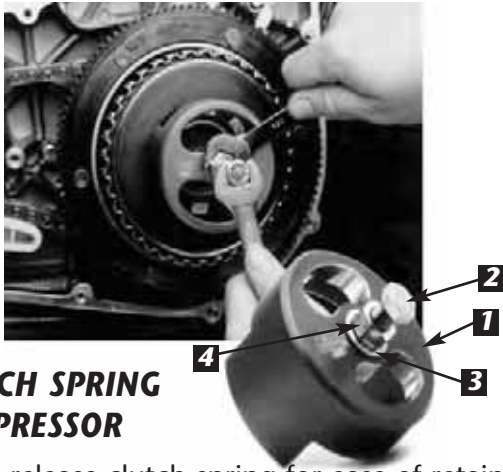

## CLUTCH SPRING COMPRESSOR

Use to release clutch spring for ease of retainer ring removal and installation. For more details see No.38515-IS instructions.

No.38515-90 - Use on all Big Twin 1990-97.  
See "NUT" for SPORTSTER® (BELOW)

### PARTS AVAILABLE SEPARATELY

NO.	QTY.	DESCRIPTION	PART NO.
1	1	CUP	38515-90-1
2	1	BOLT	2036
3	1	WASHER	2037
4	1	HEX NUT	2033
5	1	INSTRUCTION SHEET	38515-IS

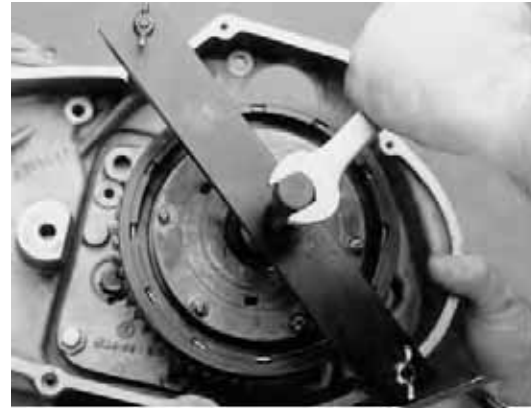

## CLUTCH SPRING COMPRESSOR

Use to remove and install clutch components. For more details see No.97178-IS instructions.

No.97178-71 - Use on all Sportster® 1971-84.

### PARTS AVAILABLE SEPARATELY

NO.	QTY.	DESCRIPTION	PART NO.
1	1	CROSS BAR	97178-71-1
2	2	STUD	97178-71-2
3	1	SCREW	1024
4	2	WING NUTS	2040
5	1	INSTRUCTION SHEET	97178-IS



## NUT FOR CLUTCH SPRING COMPRESSOR TOOL

Use to release clutch spring for ease of retainer ring removal and installation (Must be used with No.38515-90 Main Body). Available Separately. For more details see No.2285-IS instructions.

No.38515-91 - Use on all Sportster® 1991-03.  
Use on all Buell® 1991-03.  
Includes all Buell® Blast, except 1125R.

### PARTS AVAILABLE SEPARATELY

NO.	QTY.	DESCRIPTION	PART NO.
1	1	NUT	38515-91-1
2	1	WASHER	2038
3	1	RETAINING RING	2039
4	1	INSTRUCTION SHEET	2285-IS



## CLUTCH SPRING TOOL

Use to release the clutch spring tension for disassembly. For more details see No.34761-IS instructions.

No.34761-84 - Use on all Sportster®, Mid 1984-90.  
Use on all Buell® 1987-90.

# CLUTCH HUB TOOLS



## V-ROD® CLUTCH HUB ALIGNMENT TOOL

Use to align the clutch plates during assembly of the clutch basket. *For more details see No.1130-IS instructions.*

No.1130 - Use on all V-Rod® 2002-present.

## LETTERS LASERED ON FACE FOR EASY IDENTIFICATION



## CLUTCH HUB PULLER TOOL

Lettered for removal of listed items. *For more details see No.1004-IS instructions.*

No.1004A

- A** 45" - Clutch
- B** Big Twin - Clutch, all 3, 5 & 10 fingers
- C** Big Twin - Alternator Cover
- D** Sportster® - Transmission Sprocket
- E** Big Twin - Motor Sprocket
- F** Sportster® - Clutch (Early)
- G** Sportster® - Clutch (Late) And Many More Applications

### PARTS AVAILABLE SEPARATELY

NO.	QTY.	DESCRIPTION	PART NO.
1	1	PLATE	1004A-1
2	1	SCREW	1024
3	1	HARDEN TIP	1025
4	1	INSTRUCTION SHEET	1004-IS



## V-ROD® CLUTCH HUB LOCKING TOOL

Use to lock the clutch hub assembly in place when removing and installing the clutch hub nut. *For more details see No.1764-IS or No.1667-IS instructions.*

No.1674 - Use on all 2008 to present V-Rod® models.

No.1667 - Use on all 2002-2007 V-Rod® models.

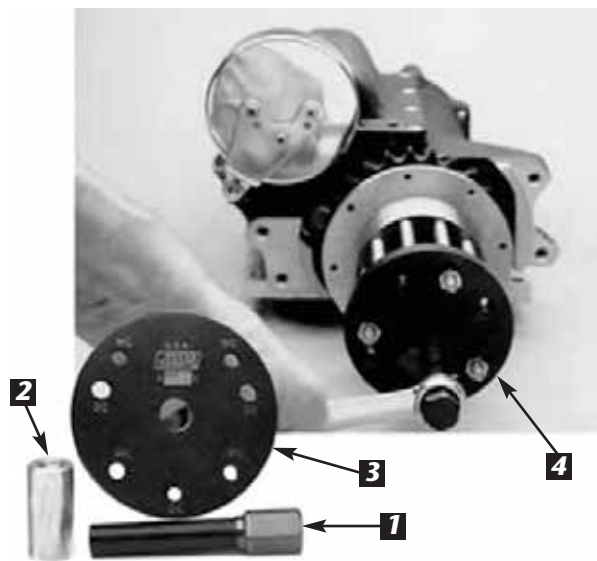

## CLUTCH HUB PULLER

Use to remove wet and dry clutch hub without removing clutch release rod. 4 bolts included for dry clutch removal. *For more details see No.95960-IS instructions.*

No.95960-52C - Use on all Big Twin 1936-90.

### PARTS AVAILABLE SEPARATELY

NO.	QTY.	DESCRIPTION	PART NO.
1	1	PULLER SCREW	1024
2	1	END PUSHER	2042
3	1	PULLER PLATE	95960-52C-3
4	4	BOLT - DRY CLUTCH REMOVAL	2041
5	1	INSTRUCTION SHEET	95960-IS



## BIG TWIN SPROCKET LOCKER

Use to lock final drive sprocket, for removing and installing sprocket nut. Use with JIMS® tool No.94660-37A. For more details see No.2260-IS instructions.

No.2260 - Use on all Big Twins 1980 to present H-D or aftermarket transmission pulleys, includes, H-D 6-Speed Cruise Drive.

### PARTS AVAILABLE SEPARATELY

NO.	QTY.	DESCRIPTION	PART NO.
1	1	TOOL, LOCKING TOP	2260-2
2	1	TOOL, LOCKING BOTTOM	2259-2
3	1	THUMB SCREW	1396
4	1	CAP	2321
5	1	INSTRUCTION SHEET	2260-IS



## PULLEY LOCK TOOL

Use this tool to lock the final drive sprocket when removing and installing the sprocket nut. For more details see No.2262-IS instructions.

No.2262 - Use on all Sportsters® 1991-present (28T and 29T only). Use on all Buell® Twins 1994-02 (28T and 29T only).

### PARTS AVAILABLE SEPARATELY

NO.	QTY.	DESCRIPTION	PART NO.
1	1	BOTTOM SPROCKET LOCK	2262-1
2	1	TOP SPROCKET LOCK	2262-2
3	1	ALLEN SCREW	2016
4	2	ALLEN SCREW	1214
5	1	CAP COVER	2321
6	1	INSTRUCTION SHEET	2262-IS



## H-D® CRUISE DRIVE 6-SPD TRANS MAIN-SHAFT PULLEY LOCKNUT SOCKET TOOL

Use to remove the larger 2-1/4" hex nut from the end of main drive gear, which secures the rear drive trans pulley. Very safe and easy to use, as the earlier JIMS® Tool No.94660-37A. Just thread on the inner support collar to end of mainshaft, place the socket over the collar with your favorite 1/2" drive tool, and unthread (left hand thread) locknut. For more details see No.989-IS instructions.

No.989 - Use on all 2006-present Dyna™ and 2007 to present FLHT & FXST.

### PARTS AVAILABLE SEPARATELY

NO.	QTY.	DESCRIPTION	PART NO.
1	1	INNER COLLAR	94660-37A-2
2	1	INSTRUCTION SHEET	989-IS



## MAINSHAFT SPROCKET/PULLEY LOCKNUT SOCKET - 1/2" DRIVE

Heavy-Duty thick wall tube. Extra long two piece design, inner collar will retain wrench to nut for safer service work. 1-7/8" hex, 1/2" Drive. For more details see No.94660-IS instructions.

No.94660-37A - Use on all Big Twins 1936-99. Use on Twin Cam® 1999-05 FXD, 1999-06 FL & 2000-06 FXST. Also aftermarket 6-speeds.

### PARTS AVAILABLE SEPARATELY

NO.	QTY.	DESCRIPTION	PART NO.
1	1	INNER COLLAR	94660-37A-2
2	1	INSTRUCTION SHEET	94660-IS



# TRANSMISSION SEAL TOOLS

## **NEW** CRUISE DRIVE (LATE 6 SPEED TRANS) MAIN CASE SEAL INSTALLER

H-D's new 6-speed transmission is a very stout piece of engineering, incorporating some of the best bearings made. These main case bearings are of such high precision that you must be very gentle when working in or around them. For this reason, JIMS has developed a driver style seal installer (not a pushing or pulling type, which could damage these bearings). This new tool installs the main seal to the correct depth, without applying any stress to the new precision bearings, or new seals. *For more details see No.786-IS instructions.*

No. 786 - Use on all 6 Speed Cruise Drive 2006 - present.

### PARTS AVAILABLE SEPARATELY

NO.	QTY.	DESCRIPTION	PART NO.
1	1	SEAL GUIDE	786-1
2	1	INSTALLER	786-2
3	1	INSTRUCTION SHEET	786-IS



## 5-SPEED MAIN DRIVE GEAR SEAL INSTALLER

Use to install the main drive gear oil seal to the proper depth with transmission assembled. Comes with a protective sleeve for seal. We recommend using JIMS® seal No's.12013A & 12035A. The sleeve can also be used when installing transmission assembly to protect main drive gear inner bearings. *For more details see No.2256-IS instructions.*

No.2256 - Use on all 5-speed Big Twins and aftermarket 6-speed 1980-2006 except 2006 Dyna.

### PARTS AVAILABLE SEPARATELY

NO.	QTY.	DESCRIPTION	PART NO.
1	1	DRIVER	2256-1
2	1	SLEEVE	2256-2
3	1	INSTRUCTION SHEET	2256-IS



## TRANSMISSION CASE SHIFTER SHAFT SEAL **NEW** INSTALLER

Developed in conjunction with Hiro Koiso, one of

JIMS sponsored Bonneville racers, these two simple tools make installing the shifter shaft seal precise and effortless. They align, center and install the shifter seal to the right depth on all EVO, Twin Cam Big Twin. *For more details see No.767-IS instructions.*

**NEW** No. 767 - Use to install H-D seal No. 37101-84B on 2006 to present H-D 6-Speed Cruise Drive transmissions.

No. 768 - Use to install H-D seal No. 12045 on all EVO Big Twins 1980 - 1999 or on H-D Twin Cam 5-Speed 1999, - 2006 FXST, FLH and FXD - 2005.



## 6-SPEED TWIN CAM® MAIN DRIVE GEAR SEAL INSTALLER

This tool is designed to properly align and install to the right depth, the main drive gear seal, H-D® No.12077 into the end of the gear. This can be performed while the assembled transmission is either on a bench or in the motorcycle chassis. *For more details see No.972-IS instructions.*

No.972 - Use on all 6-Speed Twin Cam® 2006-present FXD's & 2007-present FXST's & FL's.

### PARTS AVAILABLE SEPARATELY

NO.	QTY.	DESCRIPTION	PART NO.
1	1	SEAL DRIVER	972-1
2	1	SLEEVE	2256-2
3	1	INSTRUCTION SHEET	972-IS



## SEAL DRIVER EARLY & LATE 5-SPEEDS

Use to install the main seal in transmission. This tool will press in the seal as flat and straight as possible to .050" below housing for a no leak fit. Use with JIMS® tool No.95660-42. For more details see No.95660-IS instructions.

Endorsed By



No.95660-85 - Use on all 5-speed Big Twins and after-market 6-speed 1980-2006 except 2006 Dyna.

No.2346 - Use on all Big Twin 1980-84 5-Speeds.

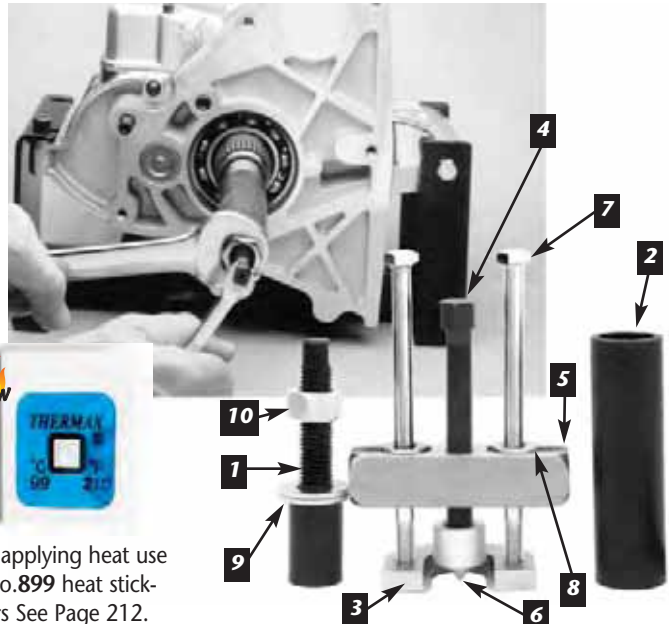

NEW

If applying heat use No.899 heat stickers See Page 212.

## MAINSHAFT BEARING RACE TOOL

Use to remove and install the bearing inner race on the transmission mainshaft.

No.34902-84 - Use on all Big Twin Late 1984-present. Use on all Twin Cam® 'A' and 'B'.

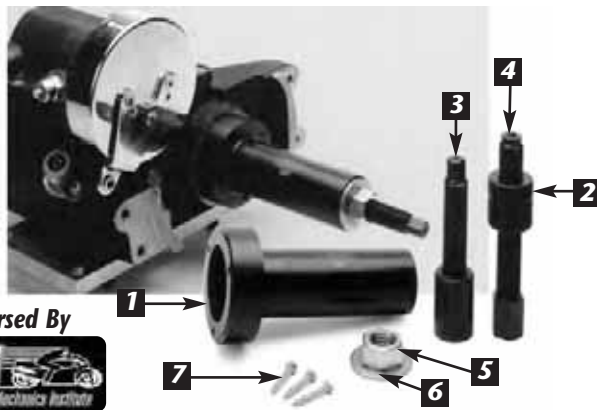

Endorsed By



## 4-SPEED TRANSMISSION MAIN SEAL TOOL

Use to install and remove main seal in all 1936-76 4-Speed transmissions, as well as installing all other Big Twin main seals. This tool will push the seal in as flat and straight as possible to .050" below housing for a no leak fit. To order other drivers for later 4-Speeds and 5-Speeds - see this page. For more details see No.95660-IS instructions.

No.95660-42 - Use on all Big Twin 1941-79.

### PARTS AVAILABLE SEPARATELY

NO.	QTY.	DESCRIPTION	PART NO.
1	1	LEFT HAND THREADED EXTENSION	2139
2	1	PUSHER TUBE	2140
3	1	PULLER PLATE	34902-84-3
4	1	SCREW	1024
5	1	PULLER BAR	2013
6	1	HARDEN TIP	1025
7	2	BOLT	2030
8	2	FLAT WASHER	2212
9	2	FLAT WASHER	2020
10	1	NUT	2032
11	1	INSTRUCTION SHEET	34902-IS

### PARTS AVAILABLE SEPARATELY

NO.	QTY.	DESCRIPTION	PART NO.
1	1	HANDLE	95660-42-1
2	1	REMOVER INSERT	95660-42-2
3	1	INSTALLER	2139
4	1	REMOVER SCREW	1024
5	1	NUT	2032
6	2	SAE WASHER 5/8"	2020
7	4	#8 SELF TAP SCREW	95660-42-7
8	1	INSTRUCTION SHEET	95660-IS



Endorsed By



## SEAL DRIVER LATE 4-SPEEDS

Use to install the main seal in transmission. This tool will press in the seal as flat and straight as possible to .050" below housing for a no leak fit. Use with JIMS® Tool No.95660-42. For more details see No.95660-IS instructions.

No.95660-77 - Use on all Big Twin 1982-86 4-Speeds.

# TRANSMISSION GEAR & BEARING TOOLS



## H-D CRUISE DRIVE 6-SPEED MAINDRIVE GEAR & BEARING REMOVER / INSTALLER KIT

This is a complete kit for servicing the main drive gear or the main bearing on the latest H-D® 6-speed transmission. This precision tool removes and installs both parts correctly without damaging the case. *For more details see No.900-IS instructions.*

No. 900 - Use on all Twin Cam H-D 6-speed Cruise Drive models. 2006 Dyna's and all 2007 to present Twin Cam models.



### PARTS AVAILABLE SEPARATELY

NO.	QTY.	DESCRIPTION	PART NO.
1	1	BEARING REMOVER	900-1
2	1	INSTALLATION CUP	987-1
3	1	INSTALLER/REMOVER BAR	987-2
4	1	INSTALLER PLATE	981-1
5	1	RECEIVER CUP	1720-2
6	1	SCREW, 4" LG.	1456
7	1	SCREW, 8" LG.	2137
8	1	SCREW, 12" LG.	2138
9	1	NUT	2136
10	1	WASHER	2038
11	1	BEARING	2010
12	1	WASHER	1735



## H-D® CRUISE DRIVE 6-SPD TRANSMISSION MAIN BEARING INSTALLER TOOL

Use this tool to safely install a new main bearing using hand tools. This job can be performed with the transmission still in the frame. Tool will hold bearing square to it's bore, eliminating any marring of the bearing bore. This tool is used in the same manner as JIMS® Tool No.35316-80 that you've been using for years. *For more details see No.987-IS instructions.*

No.987 - Use on all 2006-present Dyna™ and 2007 present FL & FXST.

### PARTS AVAILABLE SEPARATELY

NO.	QTY.	DESCRIPTION	PART NO.
1	1	INSTALLER CUP	987-1
2	1	BEARING INSTALLER PLATE	987-2
3	1	BEARING	2010
4	1	12" BOLT	2138
5	1	NUT	2136
6	1	WASHER	2038
7	1	WASHER	1735
8	1	INSTRUCTION SHEET	987-IS

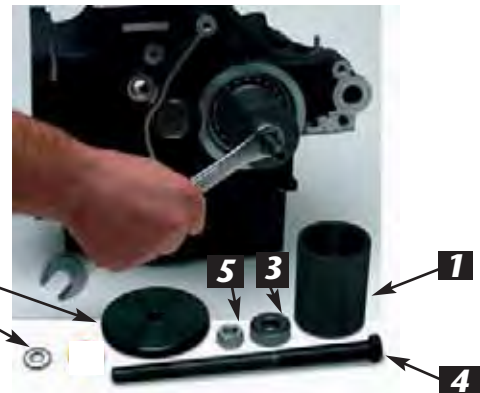

## H-D® CRUISE DRIVE 6-SPEED MAIN DRIVE GEAR INSTALLER TOOL

Use this tool to safely install a new or newly repaired main drive gear. This job can be performed with the transmission still in the frame, with hand tools. This tool will hold the main drive gear square to it's bearing bore, eliminating any marring of gear or bearings. *For more details see No.981-IS instructions.*

No.981 - Use on all 2006-present Dyna™ and 2007-present FL & FXST.

### PARTS AVAILABLE SEPARATELY

NO.	QTY.	DESCRIPTION	PART NO.
1	1	INSTALLER CUP	981-1
2	1	BEARING INSTALLER PLATE	35316-80-7
3	1	BEARING	2010
4	1	8" BOLT	2137
5	1	NUT	2136
6	1	WASHER	2038
7	1	INSTRUCTION SHEET	981-IS



# MAINSHAFT & MAIN DRIVE GEAR TOOLS

## H-D CRUISE DRIVE 6-SPEED MAINDRIVE GEAR REMOVER TOOL

This tool removes the main drive gear from the main bearing correctly while in the transmission case. This eliminates the need of an arbor press and the risk of case damage. For more details see No.901-IS instructions.

No. 901 - Use on all Twin Cam H-D 6-speed Cruise Drive models. 2006 Dyna's and all 2007 to present Twin Cam models.

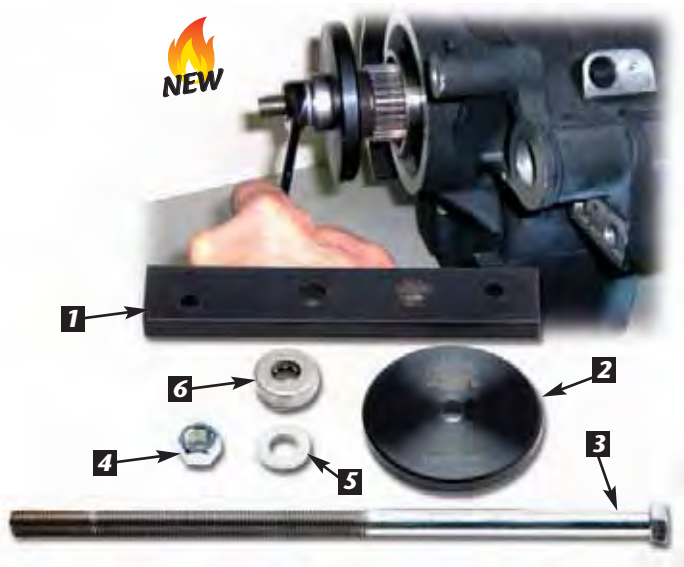

### PARTS AVAILABLE SEPARATELY

NO.	QTY.	DESCRIPTION	PART NO.
1	1	INSTALLATION BAR	987-2
2	1	MAINDRIVE GEAR WASHER	35316-80-7
3	1	SCREW 12" LG	2138
4	1	NUT	2136
5	1	WASHER	2038
6	1	BEARING	2010
7	1	WASHER	1735

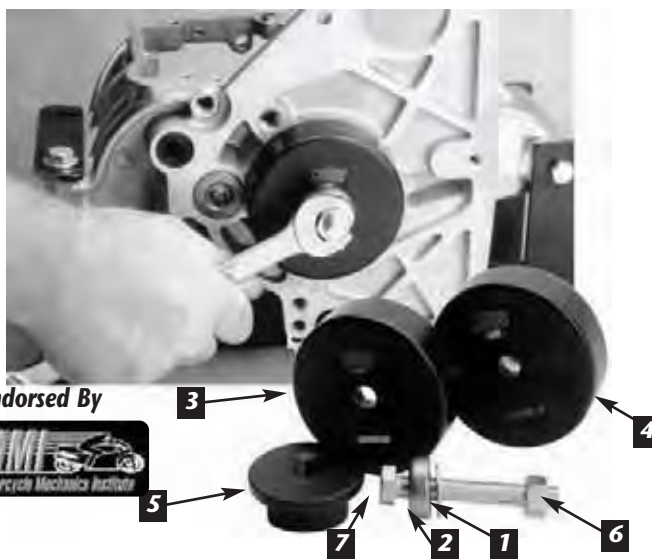

Endorsed By



## 5-SPEED MAIN BEARING REMOVER

Forget that block of wood and hammer to remove the main bearing! JIMS® Main Drive Gear Bearing Remover tool will remove the old bearing straight without possible damage to the transmission case, and without removing the transmission case. For more details see No.1720-IS instructions.

No.1720 - Use on all 5-speed Big Twins and aftermarket 6-speed 1980-2006 except 2006 Dyna.

### PARTS AVAILABLE SEPARATELY

NO.	QTY.	DESCRIPTION	PART NO.
1	1	FLAT WASHER	2038
2	1	BEARING	2010
3	1	TOOL, RECEIVER EARLY BEARING	1720-3
4	1	TOOL, RECEIVER LATE BEARING	1720-2
5	1	TOOL, PRESS PLATE BEARING REMOVER	1720-1
6	1	NUT	2136
7	1	HEX HEAD BOLT	1219
8	1	INSTRUCTION SHEET	1720-IS

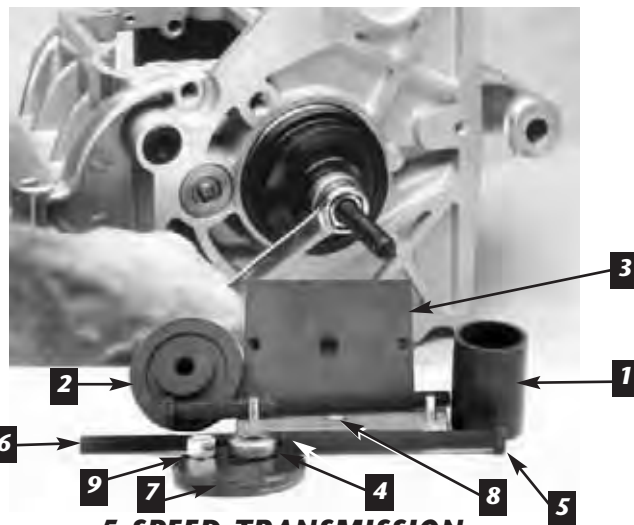

## 5-SPEED TRANSMISSION MAIN DRIVE GEAR TOOL

Use to remove and install the main drive gear. Also installs the main bearing without removing transmission case. This tool will NOT damage bearing or main drive gear during installation. For more details see No.35316-IS instructions.

No.35316-80 - Use on all 5-speed Big Twins and aftermarket 6-speed 1980-2006 except 2006 Dyna & Sportster 91-05.

### PARTS AVAILABLE SEPARATELY

NO.	QTY.	DESCRIPTION	PART NO.
1	1	INSTALLER CUP	35316-80-1
2	1	BEARING INSTALLER PLATE	35316-80-2
3	1	MAIN PLATE	35316-80-3
4	1	BEARING	2010
5	1	8" BOLT	2137
6	1	12" BOLT	2138
7	1	GEAR PLATE	35316-80-7
8	1	XL MAIN PLATE	35316-91
9	1	NUT	2136
10	1	INSTRUCTION SHEET	35316-IS

# TRANSMISSION DOOR BEARING TOOLS



## H-D® CRUISE DRIVE 6-SPEED TRANSMISSION DOOR REMOVER TOOL

Use this tool to remove (pull) the complete door with gears and shafts from the transmission. No longer will you need to remove the trap door by prying or hitting with a hammer. Just prepare the trans for disassembly, bolt this tool to the outside of door, and place the two supplied press pins into the two screw holes of trans case. Thread in two of the screws, securing the door to case, and the door is pulled from case. Can be used with transmission in frame. For more details see No.984-IS instructions.

No.984 - Use on all 2006-present Dyna™ and 2007-present FLHT & FXST.

### PARTS AVAILABLE SEPARATELY

NO.	QTY.	DESCRIPTION	PART NO.
1	4	SCREW, 1/4"	2135
2	2	DOWEL PIN	634
3	1	TOOL PLATE	984-1
4	1	INSTRUCTION SHEET	984-IS

Endorsed By



## H-D® CRUISE DRIVE 6-SPEED TRAP DOOR BEARING REMOVER / INSTALLER

This new innovative tool will accurately install a lubed ball bearing into the transmission trap door. Also removes bearing without error and can be performed on a work bench, no need for an arbor press. For more details see No.911-IS instructions.

No. 911 - Use on all Twin Cam H-D 6-speed Cruise Drive models. 2006 Dyna's and all 2007 to present Twin Cam model

### PARTS AVAILABLE SEPARATELY

NO.	QTY.	DESCRIPTION	PART NO.
1	1	LOWER PLATE	911-1
2	1	UPPER PLATE	911-2
3	1	INSTALLER PILOT	1077-2
4	1	SCREW	1024
5	3	ALLEN SCREW 1/4-20 X 2"	1203
6	1	NUT 5/8-18	1065
7	1	WASHER 5/8 SAE	1064

## 5-SPEED DOOR PULLER

Use to remove Big Twin 5-Speed transmission door. This tool easily removes the transmission door, with gears and shafts attached and without any scratches or frustrations. Puller will not damage door bearing. For more details see No.2283-IS instructions.

No.2283 - Use on all 5-speed & aftermarket 6-Speed transmissions, including Twin Cam® 1999-05 FXD, 1999-06 FL and 2000-06 FXST.

# TRANSMISSION DOOR BEARING TOOLS



Endorsed By



## 5-SPEED TRANSMISSION SHAFT INSTALLER

This tool allows installation of transmission shafts without the use of a hydraulic or arbor press. For more details see No.2189-IS instructions.

No.2189 - Use on all 5-speed Big Twins and aftermarket 6-speed 1980-2006 except 2006 Dyna.

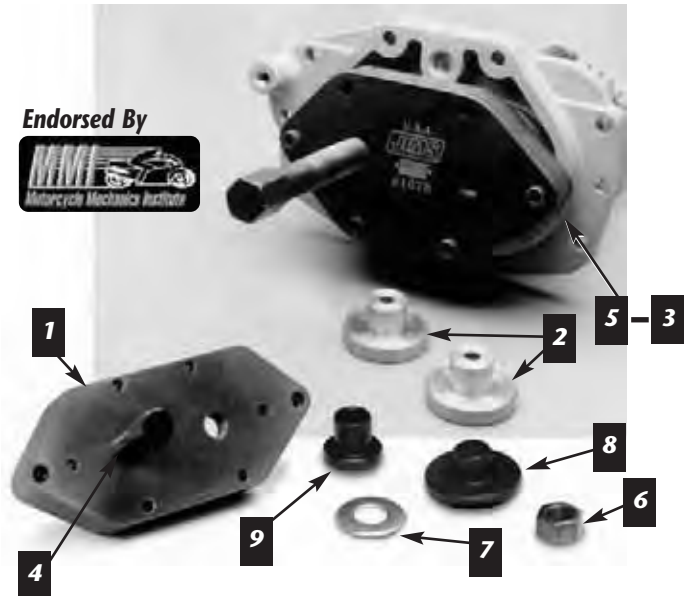

Endorsed By



## TRANSMISSION TRAP DOOR PULLER AND BEARING TOOL

This tool will remove and replace the transmission door bearings H-D® No.8998 or 8992. It can also be used to remove the transmission door for replacement without removing the complete transmission assembly. Door bearings must be replaced if using this tool to pull door off case. Replacement bearings; see page 104. **\*NOTE:** Old No.1078-4 will not fit No's 1077-2 or 1077-3. For more details see No.1078-IS instructions.

No.1014 - Use on all 5-speed Big Twins and aftermarket 6-speed 1980-2006 except 2006 Dyna.



## TRANSMISSION ACCESS COVER PULLER TOOL

Use to remove transmission access cover which is press fit on two dowel pins. For more details see No.95560-IS instructions.

No.95560-57 - Use on all Sportster® 1954-85.

### PARTS AVAILABLE SEPARATELY

NO.	QTY.	DESCRIPTION	PART NO.
1	1	BASE, PULLER AND INSTALLER	1014-1
2	2	PILOT, INSTALLING (NO.8998) BEARING	1078-2
3	6	WASHER	1683
4	1	SCREW	1024
5	6	SOCKET HEAD CAP SCREW	1203
6	1	NUT	2000
7	1	FLAT WASHER	2020
8	1	PILOT, INSTALLER (NO.8992) BEARING	1077-2
9	1	PILOT, REMOVER (NO.8992) BEARING	1077-3
10	1	INSTRUCTION SHEET	1078-IS

### PARTS AVAILABLE SEPARATELY

NO.	QTY.	DESCRIPTION	PART NO.
1	1	SCREW	2130
2	1	INSTRUCTION SHEET	95560-IS





## RIGHT SIDE DRIVE TRAP DOOR PULLER

This tool will remove the transmission door for service work without removing the complete transmission assembly. For more details see No.998-IS instructions.

No.998 - Use on all JIMS® Right Side Drive transmissions and other aftermarket right side drive transmissions.

### PARTS AVAILABLE SEPARATELY

NO.	QTY.	DESCRIPTION	PART NO.
1	1	PULLER BODY	998-3
2	1	SCREW	1024
3	1	INSTRUCTION SHEET	998-IS



## FAT 5™ TRANSMISSION TRAP DOOR PULLER AND BEARING TOOL

This tool will remove and replace the transmission door bearings. It can also be used to remove the transmission door for replacement without removing the complete transmission assembly. Door bearings must be replaced if using this tool to pull door off case. Replace bearings with JIMS® No.8992. For more details see No.1077-IS instructions.

No.1077 - Use on all JIMS® FAT 5™ overdrive transmissions.

### PARTS AVAILABLE SEPARATELY

NO.	QTY.	DESCRIPTION	PART NO.
1	4	BASE, PULLER AND INSTALLER	1077-4
2	2	PILOT, INSTALLING, BEARING	1077-2
3	2	PILOT, REMOVING, BEARING	1077-3
4	2	SCREW, TOOLS	1024
5	4	SOCKET HEAD CAP SCREW	1212
6	2	NUT	2000
7	2	FLAT WASHER	2020
8	4	FLAT WASHER	1683
9	1	INSTRUCTION SHEET	1077-IS

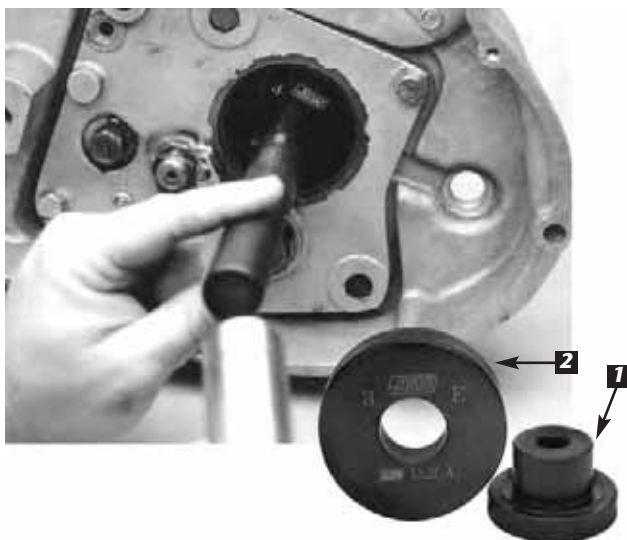

## SPORTSTER® MAINSHAFT BEARING INSTALLER TOOL

Use to install the main bearing in case. Use with JIMS® Handle No.33416-80. For more details see No.34810-IS instructions.

No.34810-84 - Use on all Sportster® Late 1984-90. Use on Buell® 1987-90.

### PARTS AVAILABLE SEPARATELY

NO.	QTY.	DESCRIPTION	PART NO.
1	1	INSTALLING COLLAR	34810-84-1
2	1	COLLAR	34810-84-2
3	1	INSTRUCTION SHEET	34810-IS

## 5-SPEED MAINDRIVE GEAR BEARING & SEAL INSTALLER



Use to install both bearings and the seal on the clutch side. *For more details see No.34734-IS instructions.*

No.34734-80 - Use on all Big Twin 5-speed 1980-1990.

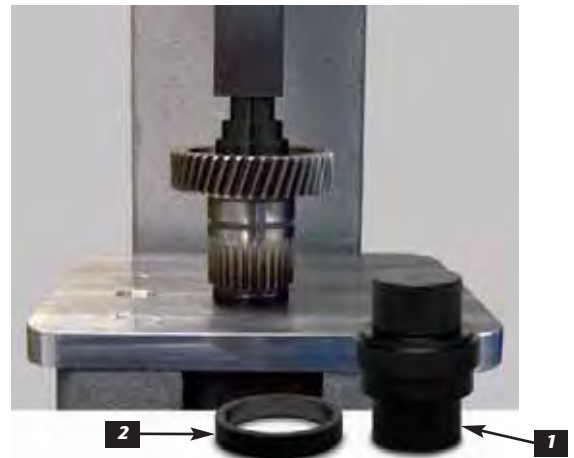

## H-D® CRUISE DRIVE 6-SPEED MAIN DRIVE GEAR, BEARING & SEAL INSTALLER TOOL

Use this tool to safely install new main drive gear bearings and seal. This tool will hold bearings and seal square to it's bore, eliminating any marring of the bearings and seals and installing both to the right depth. This tool is used in the same manner as JIMS® Tool No.37842-91 that you've used for years. *For more details see No.986-IS instructions.*

No.986 - Use on all 2006-present Dyna™ and 2007-present FL & FXST.

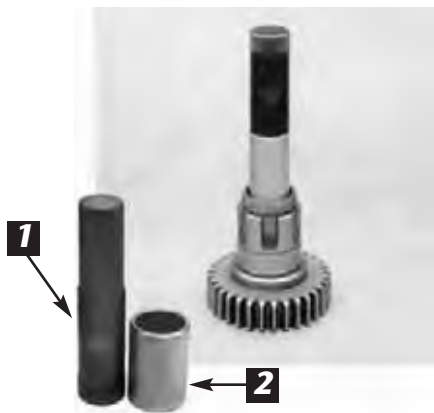

## MAIN DRIVE GEAR BUSHING TOOL

Use to remove and install the main drive gear bushings, also to remove Big Twin cam bushing 1970-present. *For more details see No.1005-IS instructions.*

No.1005 - Use on all Big Twin 1936-86 4-Speeds.

### PARTS AVAILABLE SEPARATELY

NO.	QTY.	DESCRIPTION	PART NO.
1	1	BEARING REMOVER	986-1
2	1	SEAL INSTALLER	986-2
3	1	INSTRUCTION SHEET	986-IS

### PARTS AVAILABLE SEPARATELY

NO.	QTY.	DESCRIPTION	PART NO.
1	1	DRIVER	1005-1
2	1	SLEEVE	1005-2
3	1	INSTRUCTION SHEET	1005-IS



## TRANSMISSION MAIN DRIVE GEAR BEARING TOOL

Use to install main bearing H-D No.8905 or No.8906 to the factory depth. *For more details see No.33428-IS instructions.*

No.33428-78 - Use on all Big Twin 1979-85 4-Speed.



## MAIN DRIVE GEAR BEARING TOOL

Use to install inner and outer 5th gear bearings to factory depth. New bearing depth incorporated, will still work on early depth. *For more details see No.37842-IS instructions.*

No.37842-91 - Use on all 5-speed Big Twins and aftermarket 6-speed 1980-2006 except 2006 Dyna. Use on Sportster or Buell 1991 - 2005.

## H-D® CRUISE DRIVE SHIFT FORK SHAFT REMOVER TOOL

Tool loosens and removes both shifter shafts from trans door, allowing further disassembly of transmission. For more details see No.985-IS instructions.

No.985 - Use on all 2006-present Dyna™ and 2007- to present FLH & FXST.



## TRANSMISSION GEAR SPACING TOOL

Use to align main and countershafts when checking proper gear spacing. For more details see No.35820-IS instructions.

No.35820-86 - Use on all Sportster® 1986-90.  
Use on all Buell® 1987-90.

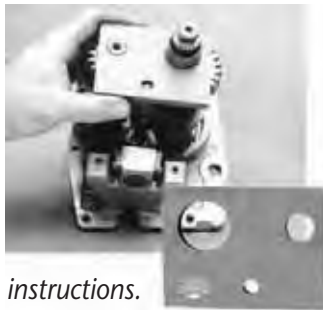

## EXTERNAL LOCK RING PLIERS

These pliers jaws are scored on the outside to hold the snap ring JIMS® No.11087K for 5-Speed transmission shafts. For more details see No.2362-IS instructions.

No.2362 - Use on all 5-speed Big Twins and aftermarket 6-speed 1980-2006 except 2006 Dyna. Use on Sportster or Buell 1957 - present.



## CRUISE DRIVE SHIFTER SHAFT SLEEVE REMOVER & INSTALLER TOOL

This tool allows you to remove and install H-D No.35186-06 shifter shaft sleeve without removing the transmission case from the chassis. This tool installs sleeve to the correct depth in case without error or damage. For more details see No.1658-IS instructions.

No. 1658 - Use on all 2006 to present 6-speed Cruise Drive models.



## SHIFTER SHAFT SLEEVE TOOL

Use to remove and install the shifter shaft sleeve in all 5 & 6 aftermarket speeds. This tool may be used to remove, install replacements, or upgrade shifter shaft sleeve, assembly, and drum. For more details see No.1664-IS instructions.

No.1664 - Use to upgrade to latest shifter assembly for 5-Speeds, 1980-99 Big Twins, and 1980-00 FLHT, FXR, and FXD.

Use to replace shifter sleeve for 5-Speeds 2000-06 FXST, 2001-06 FLHT, and 2001-05 FXD.

### PARTS AVAILABLE SEPARATELY

NO.	QTY.	DESCRIPTION	PART NO.
1	1	SLEEVE REMOVER	1664-1
2	1	SLEEVE INSTALLER	1664-2
3	1	THRUST BEARING	1663
4	2	THRUST WASHER	1662
5	1	ALLEN SCREW	1661
6	1	INSTRUCTION SHEET	1664-IS





## SHIFT FORK GAUGE

Use to set and align shift forks on plate-type shifters.  
For more details see No.96385-IS instructions.

No.96385-78A - Use on all Big Twin 1979-86 4 - Speeds.

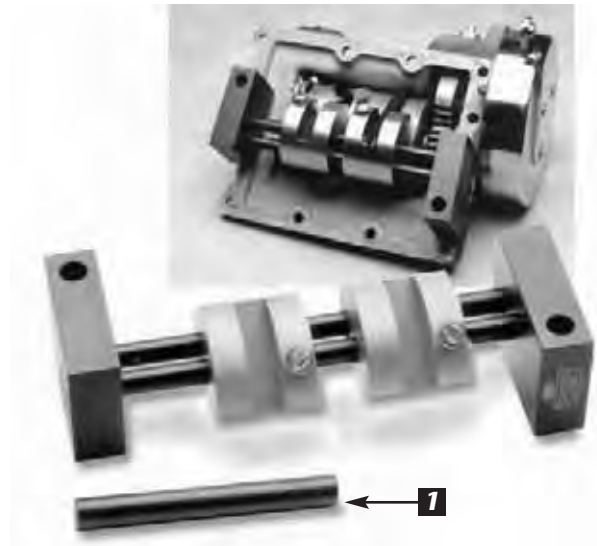

## SHIFT FORK GAUGE

Use to set and align shift forks on drum-type shifters.  
For more details see No.96384-IS instructions.

No.96384-39 - Use on all Big Twin 1939-78 4 - Speeds.

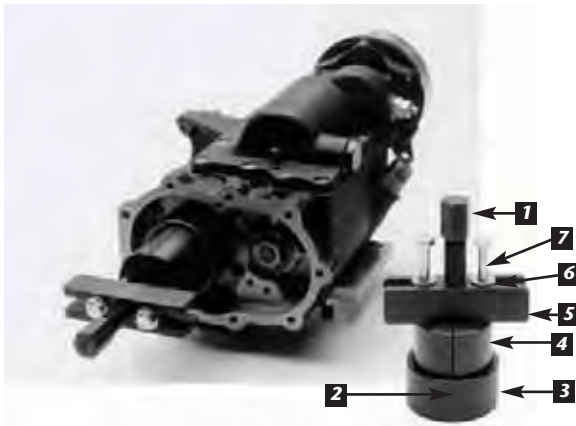

## 4-SPEED MAINSHAFT CLUTCH GEAR PULLER

(GEAR NO.'S 33381-39 & 33560-75)

This tool was designed specifically to remove the starter clutch gear without damage to the gear or shaft. This tool will not slip off the gear. For more details see No.1007-IS instructions.

No.1700 - Use on all Big Twin 4-Speeds 1936-86, with kick starter.

### PARTS AVAILABLE SEPARATELY

NO.	QTY.	DESCRIPTION	PART NO.
1	1	SCREW	1024
2	1	HARDEN TIP	1025
3	1	RING	1044-TU-2
4	2	STARTER CLUTCH GEAR PULLER	1700-1
5	1	PULLER BAR	2013
6	2	HEAVY FLAT WASHER	2014
7	2	BOLT	1217
8	1	INSTRUCTION SHEET	1700-IS

### PARTS AVAILABLE SEPARATELY

NO.	QTY.	DESCRIPTION	PART NO.
1	1	GAUGE PIN 3/8"	96384-39-4
2	1	INSTRUCTION SHEET	96384-IS



## TRANSMISSION STUD INSTALLER TOOL

Use on all stock and aftermarket transmissions that use bottom mounting studs. For more details see No.1050-IS instructions.

No.1050 - Use on all Big Twin 1936-86 4-Speeds.

Use on all Softail® 1985-99 5-Speeds.

### PARTS AVAILABLE SEPARATELY

NO.	QTY.	DESCRIPTION	PART NO.
1	1	INSTALLER BODY	1050-1
2	1	SCREW	1049
3	1	NUT	2205
4	1	INSTRUCTION SHEET	1050-IS



## TOURING MODEL STEERING HEAD STEM NUT WRENCH

This tool was submitted to us by Hiro Koiso a hands on flat rate technician, experienced engine builder and a JIMS sponsored Bonneville record holder in numerous classes.

Hiro came to us with a great flat rate time saver stem nut tool for use on Touring Model Harleys. Normally to get access to the top stem nut you would need to remove the radio package. With this tool you are able to loosen, tighten and torque to spec. the 1-1/2" stem nut without radio removal and ultimately saving you 45 minutes for an experienced mechanic! For more details see No.977-IS instructions.

No.977 - Use on 1996 to present FLHT and 1994 to present FLHR.



## 35MM HEX TOP FORK NUT SOCKET 3/8" DRIVE

Use to remove or install top fork nut on glide forks. Has rubber protector on inside to prevent damage to chrome nut (Will clear most bars). For more details see No.2244-IS instructions.

No.2244 - Use on all Sportsters® & Big Twins.



Endorsed By



## FORK NUT SOCKET

Use to remove and install top fork tube plug. Eliminates possible burring of plug caused by wrenches. For more details see No.2043-IS instructions.

No.2043 - Use on all 1948 and later Wide Glide models.

## 49MM FORK DUST AND FORK SEAL INSTALLER TOOL

This tool is designed to install the lower leg 49mm fork seal squarely into the bore without damaging the seal lip surface. Two piece design. For more details see No.2049-IS instructions.

No.2049 - Use on all FXD'S, 2006 - present and all V-ROD'S 2002-present (except inverted fork models).



## FORK SEAL & CAP INSTALLERS

Use to install fork seals, dust seals, and chrome caps. Lightly grease to keep from scratching fork tubes. For more details see No.2044-IS instructions.

No.2044 - 39mm slider with Delrio plastic indestructible cap. 2 piece kit.



## 35mm & 41mm SLIDERS SOLD SEPARATELY

### PARTS AVAILABLE SEPARATELY

NO.	QTY.	DESCRIPTION	PART NO.
1	1	35MM SLIDER	2045
2	1	39MM SLIDER	2046
3	1	41MM SLIDER	2047
4	1	INDESTRUCTIBLE DELRIN CAP	2048
5	1	INSTRUCTION SHEET	2044-IS



## FORK STEM BEARING REMOVER

Use this tool to remove the lower fork stem (Triple Clamp) tapered bearing. *For more details see No.1414-IS instructions.*

No.1414 - Use on all lower fork stems that use a H-D® No.48300-60 style bearing. Order JIMS® Hard End Cap, No.1048 below when using on early XL 1978-81.

### PARTS AVAILABLE SEPARATELY

NO.	QTY.	DESCRIPTION	PART NO.
1	1	BEARING REMOVER	1414-1
2	2	SCREW	1024
3	1	PULLER BAR	2013
4	2	3/8" - 16 X 11" BOLTS	1717
5	2	3/8" SAE WASHER	2031
6	1	HARDENED TIP	1025
7	1	INSTRUCTION SHEET	1414-IS

## HARD CAP

This hard cap will protect the 3/4" fork stem when using the above tool No. 1414 on Sportsters. Also works on 1955 to 2006 Big Twin sprocket shafts, when pressing flywheels out of engine cases. See page 184. *For more details see No.1048-IS instruction sheet.*

No.1048 - Use on 1978-1981 Sportsters



## FRONT FORK COMPRESSOR TOOL

Use to compress the fork springs in cartridge style shocks when servicing or rebuilding. The compressor can be mounted in a vise

for easy hands free servicing. Also includes an adapter for FL forks to eliminate direct contact with spring coil and a special rod to pull up the fork damper rod. *For more details see No.1776-IS instructions.*

No.1776 - Use on all cartridge-style shocks fork assemblies.

### PARTS AVAILABLE SEPARATELY

NO.	QTY.	DESCRIPTION	PART NO.
1	1	MAIN BODY	1776-11
2	1	SLIDE, MAIN BODY	1776-10
3	1	FL ADAPTER	1776-3
4	1	DAMPER ROD EXTENTIONS	1776-9
5	1	SPECIAL ALLEN SCREW	1776-6
6	1	INSTRUCTION SHEET	1776-IS



## EXTENDED FORK COMPRESSOR ADAPTER TOOL

This tool must be used with JIMS Front Fork Compressor tool No.1776 above.

This adapter tool No.1777 will allow you to work on forks 2-inch undersize to approximately 16" oversized forks, depending on the original length of the fork assembly. Will not work on inverted model forks. *For more details and parts list see No.1777-IS instructions.*

No.1777 - Use on overstock length cartridge-style shocks fork assemblies.

## FORK TUBE SPRING RETAINER REMOVER/ INSTALLER TOOL



This tool has two pins that will locate inside the top of the fork tube on the spring retainer screw. You will then be able to remove or install this retainer to service the fork assembly on early drum brake fork model Sportsters and Superglides.

No.1170 - Use on 1952 - 1972 Sportsters, and 1970 - 1972 Superglide.



# FRONT FORK, NECK & SEAT TOOLS



## FORK LEG AND TUBE HOLDER TOOL

Use this tool to hold fork legs and tubes for easy hands free servicing or rebuilding. Mounts in a vise to hold the fork firmly during repair without causing damage to the fork assembly. Will not scratch finishes. *For more details see No.2251-IS instructions.*

No.2251 - Use on smaller 28mm or larger fork tubes with a maximum 2" (50mm) diameter.



## STEERING HEAD BEARING RACE INSTALLER

Use to install steering head races, stock and custom, as well as install cups in the

frame. This tool pulls the races and cups in, straight and true, without any damage. *For more details see No.1725-IS instructions.*

No.1725 - Use to install cups and races on all models, including V-Rod®.

## FORK OIL LEVEL GAUGE

This tool is designed to accurately fill the front fork tubes with fork oil. The tool has a convenient lettered scale on the pump plunger and steel oil level tube for precise measurements when servicing. Consult your service manual for the proper weight oil and the amount to fill each tube.

No.920 - Use on hydraulic front forks.



## FXST REAR SEAT MOUNTING SCREW TOOL

This tool is used on the Softail® seat mounting screw, H-D# 3075, to mount the seat to the rear fender. JIMS tool locates on the screw head to keep from scratching or damaging the rear fender or screw, when installing or removing the seat.

No. 774 - Use on 2007 - present FXST models using the H-D screw No. 3075.



## STEERING HEAD BEARING RACE REMOVER TOOL

Use to remove and install steering head bearing race. Use with JIMS® spacer No.2388 and JIMS® Tool Handle No.33416-80 below. *For more details see No.2232-IS instructions.*

No.2232 - Use on all Big Twin 1949-present. (**NOTE:** Includes aftermarket frames.) Use on Sportster® 1978-present. Use on Buell® 1987-02. Use on V-Rod® 2002-present.



## RACE & BEARING INSTALL TOOL HANDLE

Use with No's. 2232 above, 33071-73, 34810-84, 94547-80A & B, 97272-60, 788, and 97273-60. Approximately 12" long. *For more details see No.33416-IS instructions.*

No.33416-80

### PARTS AVAILABLE SEPARATELY

NO.	QTY.	DESCRIPTION	PART NO.
1	1	O-RING	2310
2	1	INSTRUCTION SHEET	33416-IS

# SWINGARM & REAR FORK TOOLS

## PIVOT BEARING REMOVER / INSTALLER TOOL

Use this tool when removing and installing the swingarm pivot bearing for 1984-present Softails® that use H-D® No.9076, or 9270A. This tool can also be used to remove and install front fender spherical bearings on Heritage Softail® Springers 1997-02 & 2004-present that use H-D® No.9149.

For more details see No.2250-IS instructions.

No.2250 - Use on all 1984-present FXST's for pivot bearing. Use on 1997-02 & 2004-present FLSTS for spherical bearing.

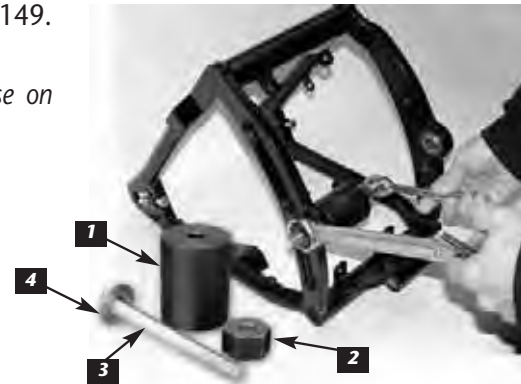

### PARTS AVAILABLE SEPARATELY

NO.	QTY.	DESCRIPTION	PART NO.
1	1	INSTALLER CUP	35316-80-1
2	1	END CAP	2250-1
3	1	SCREW	1237
4	1	WASHER	2038
5	1	INSTRUCTION SHEET	2250-IS

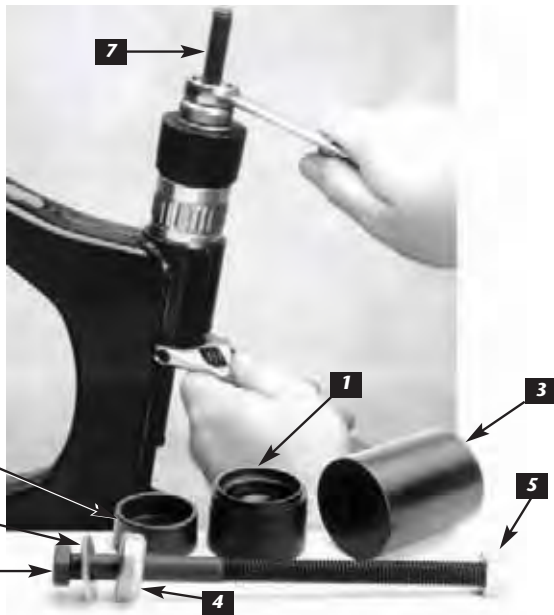

## CLEVBLOC BUSHING ASSEMBLY REMOVER / INSTALLER TOOL

Use to remove and replace swing arm clevblocs. Clevblocs, part No.47556-81, are silicone filled bushings that will be damaged if not installed properly. JIMS® tool presses on the outer sleeve of the bushing, preventing damage to the cleverbloc. Can be used with or without a press. For more details see No.1743-IS instructions.

No.1743 - Use on all FLT, FLH 1980-2001.  
Use on all FXR 1982-94, 1999 and all aftermarket FXR style frames.

### PARTS AVAILABLE SEPARATELY

NO.	QTY.	DESCRIPTION	PART NO.
1	1	PRESS PLUG	1743-1
2	1	PRESS CUP INNER	1743-2
3	1	PRESS CUP OUTER	1743-3
4	1	BEARING	2010
5	1	NUT	2136
6	1	LONG BOLT	1246
7	1	SHORT BOLT	2137
8	1	WASHER	2038
9	1	INSTRUCTION SHEET	1743-IS



## CLEVBLOC SPREADING TOOL

Use to install the swing arm in a 5-Speed rubber mount frame. When clevblocs are replaced they need to be positioned to install in the rear of the transmission. This tool will spread the swing arm clevblocs allowing for installation of the swing arm. For more details see No.1707-IS instructions.

No.1707 - Use on all Big Twin 1980-2001 FL. Use on all FXR 1982-99.

### PARTS AVAILABLE SEPARATELY

NO.	QTY.	DESCRIPTION	PART NO.
1	2	FLANGED NUT	1707-2
2	1	SHAFT	1707-1
3	1	INSTRUCTION SHEET	1707-IS

# SWINGARM, FRAME & ALIGNMENT TOOLS



## REAR AXLE NUT TORQUE ADAPTER

This new JIMS tool will make adjusting the drive belt tension or rear wheel alignment a bit easier. Saves you time by eliminating the need to remove the mufflers to perform this service. The tool is designed with a 1/2" drive receiver hole for inserting your torque wrench thus letting you torque the axle nut from an offset position. *For more details see No.906-IS instructions.*

No. 906 - Use on 2006 - present FL touring models 2008 and later. Use on V-Rod 2005-present.



## HOLLOW AXLE PLUG TOOL

Most all-late motorcycles are now using hollow axles for reduced weight and cost savings. The use of this new hollow axle has eliminated the center point of the axle, which had been used as a center point for alignment references. Lube the o-ring ends of these tools and insert in left and right ends of axle on Dyna®, and Sportster® Models. This will give you the correct center point required for safe vehicle alignment. *For more details see No.950-IS instructions.*



No.950 - Use on all Dyna® and Sportster® models 2008 to present.

### PARTS AVAILABLE SEPARATELY

NO.	QTY.	DESCRIPTION	PART NO.
1	1	AXLE PLUG, LEFT	950-1
2	1	AXLE PLUG, RIGHT	950-2
3	1	O-RING, LEFT	950-4
4	1	O-RING, RIGHT	950-3
5	1	INSTRUCTION SHEET	950-IS



## 3RD HAND AXLE LOCKER TOOL

Have you noticed, as you are torquing down the axle nut after you set the proper belt tension, (Deflection) that the welded axle nut will move to the low side of adjuster cam? This movement will allow the belt to lose adjustment. Now with the " JIMS® 3rd Hand Axle Tool", you will not need to find a helper to hold the nut or yourself having to reach around the tire and hold the nut from moving. Just place this tool over the welded nut on left side with the neck portion of the tool resting over the swing arm. Hand screw the adjusting screw to take up any slack in tool. Torque the axle nut from the right side knowing the welded nut will not turn allowing the belt to lose it's adjustment. *For more details see No.970-IS instructions.*

No.970 - Use on all 2002 and later FL.

## REAR WHEEL ALIGNMENT TOOL

Having good wheel alignment will extend belt, chain, pulley and sprocket life. Poor alignment can effect the safe handling of the motorcycle. This tool is simple, fast, and accurate to use to keep correct alignment. Also works on the new hollow axle Dynas® and Sportster® models along with JIMS® hollow axle tool No.950 above.

No.928 - Works on most Sportsters®, Dynas® and Softails® models to present.

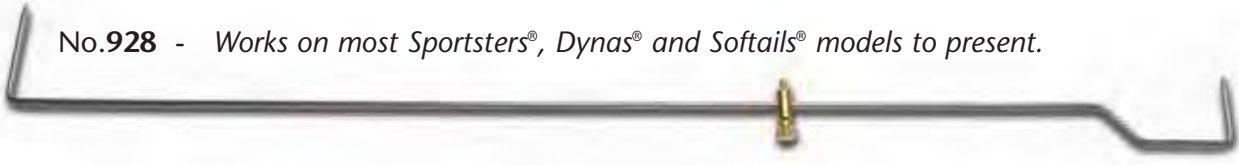



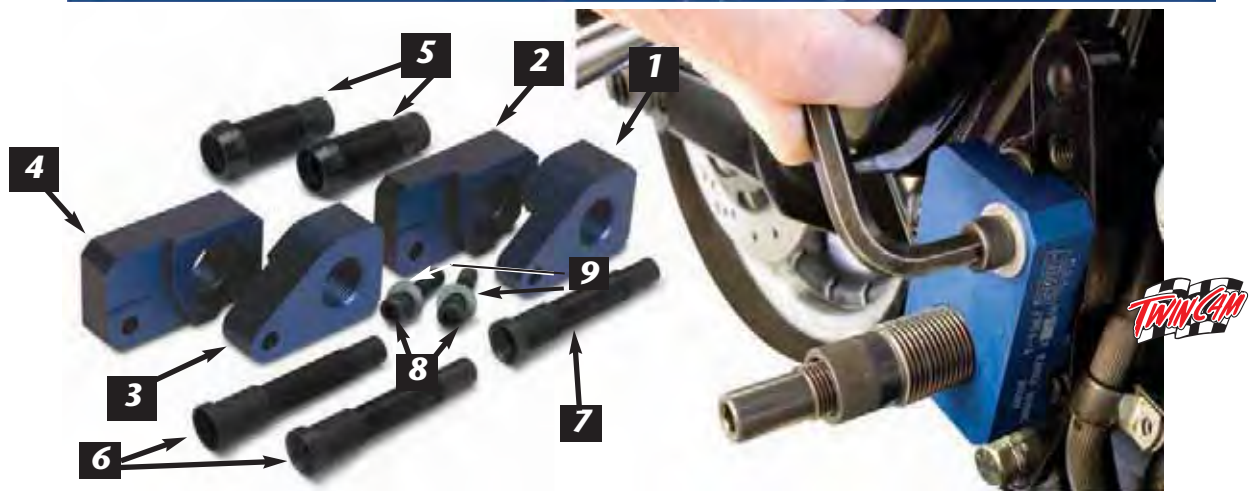

## FL POWER TRAIN ALIGNMENT TOOL

This tool easily and safely aligns the Power Train (rubber mounted engine, transmission and the swingarm assembly) to the correct position as found on most touring models. Alignment service must be performed when the engine, transmission, or swingarm has either been removed or repaired. The safety in handling and performance of the motorcycle could be greatly effected without the accurate alignment this tool provides. *For more details see No.964-IS instructions.*

No.964 - Use on 1993-2008 FLHT models.

### PARTS AVAILABLE SEPARATELY

NO.	QTY.	DESCRIPTION	PART NO.
1	1	LEFT ALIGNMENT BLOCK, 2007 TO 2008	964-1
2	1	RIGHT ALIGNMENT BLOCK, 2007 TO 2008	964-2
3	1	LEFT ALIGNMENT BLOCK, 2003-05	964-3
4	1	RIGHT ALIGNMENT BLOCK, 2003-05	964-4
5	2	PIVOT SLEEVE	964-5
6	2	ADJUSTMENT SCREW, 2002 TO 2008	964-6
7	1	ADJUSTMENT SCREW, 1993-01	964-7
8	2	ALLEN SCREW, 3/8-16X1-1/2"	1181
9	1	WASHER, 3/8", SAE	2031
10	1	INSTRUCTION SHEET	964-IS



## CHAIN & BELT ALIGNMENT TOOL

Use this state of the art, simple to use, laser tool to assure proper alignment between the rear pulley or sprocket, to the trans pulley or sprocket. Simply hold the tool to the rear pulley or sprocket and use laser guide as a straight edge to check proper alignment.

No.918 - Use on all models.



## MOTORCYCLE ALIGNMENT TOOL

Take the guesswork out of motorcycle alignment. This tool, when placed against both sides of the rear wheel, will project laser guides that check for proper alignment via guides on both sides of the front wheel. It's easy to use, and very accurate. Experienced technicians can use this tool for additional applications such as bearing alignments, primary alignment / belt alignment, frame condition, etc... A luxury tool, that will quickly become an essential tool once used.

No.919 - Use on all Big Twin, Sportsters®, and Buell® models.



## JUMBO CHAIN TOOL

This tool is designed to break roller chains up to #630 and fits all standard & O-ring chain sizes #520 to #630. Its designed to rivet chains up to #530. (not #630) Master link side plate press kit included to press on side plates on chains up to #530. (not #630) The screws and attachments are heat treated for strength and durability. The extractor pin is precisely guided by a removable guide ensuring long pin life. This may be bolted to a work bench, supported in a vise, or held by handle. When bolted to a solid surface, air or electric wrenches may be used to break chain. This tool is recommended for heavy duty use. Instructions included with tool.

No.926 - See above chain application info above for chain type and sizes.



## CHAIN PRESS TOOL KIT

Since about 1990, most new chains use press-fit type side plates on the connecting links. With this type of link the side plate cannot be installed properly without the aid of this special tool. The chain manufacturers have determined a press fit adds strength to the connecting link and should always be used.

No. 925 - Used on #520 - # 530 chain with press fit connecting links either standard or o-ring style.



## REPLACEMENT PRESS PLATES ONLY

No.924 - Used on tool No.925 above.



## MASTER LINK PLIERS

Designed to simplify installation and removal of clip-type master links. One tip is shorter and notched to be placed on the pin which allows the longer tip to push the clip.

No.921 - Master Link Pliers.



## BELT TENSION GAUGE

This compact designed tool is used to assist in properly adjusting secondary belt tension with a 10 lb.. specification. Tool has an easy to read scale. Use on all rear belt driven O.E.M. or aftermarket motorcycles.

No.923 - Used on all rear belt driven O.E.M. or aftermarket motorcycles.



## LATE SEALED WHEEL BEARING REMOVER AND INSTALLER KIT

Use to remove and install "new style" sealed wheel bearings without damaging the wheel. Includes new remover and installer for 25mm bearing, with or without ABS. Also included is a 30 pack of "surface Temperature Indicating Strips." These are used to assist in removing a stubborn bearing when applying heat to a hub surface. For more details see No.1042-IS instructions.

No.939 - Use on all 2000-present Twin Cam® models, and all 2000 Sportsters® models, and V-Rod®s 2002-present.

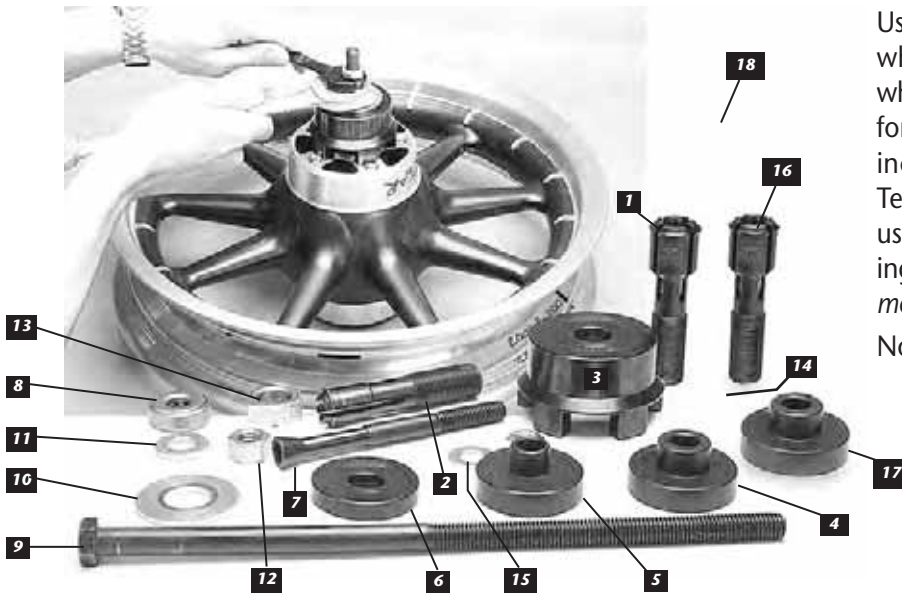

### 25MM WHEEL BEARING REMOVER AND INSTALLER TOOL



This tool is used to remove and install the new front 25mm H-D® bearing, including ABS or non ABS wheel bearings on most of the 2007 to present with 25mm bearing models. Note: This

tool must be used with the earlier JIMS® wheel bearing installer / remover Tool No.1042 above. For more details see No.1042-IS instructions.

No.958 - Use on all 2007-present wheels using 25mm wheel bearing, ABS or non-ABS.

#### PARTS AVAILABLE SEPARATELY

NO.	QTY.	DESCRIPTION	PART NO.
1	1	WHEEL BEARING PULLER (1.00" ID)	1042-1
2	1	WHEEL BEARING PULLER (.750" ID)	1042-2
3	1	MAIN BODY, PULLER	1042-3
4	1	BEARING INSTALLER, LARGE	1042-4
5	1	BEARING INSTALLER, SMALL	1042-5
6	1	INSTALLER BACKING PLATE	1042-6
7	1	EXPANDER DOWEL	1042-7
8	1	BEARING	2010
9	1	BOLT, 1/2-13 X 12"	2138
10	1	BRASS WASHER	1099
11	1	FLAT WASHER, 1/2 SAE	2038
12	1	NUT, 1/2-13	2136
13	1	NUT, 3/4-16	1098
14	1	NUT, 7/16-14	7515
15	1	WASHER, 7/16 SAE	2037
16	1	REMOVER, 25MM	1042-8
17	1	INSTALLER, 25MM	1042-9
18	1	TEMPERATURE STRIPS (30)	899
19	1	INSTRUCTION SHEET	1042-IS

#### PARTS AVAILABLE SEPARATELY

NO.	QTY.	DESCRIPTION	PART NO.
1	1	REMOVER	1042-8
2	1	INSTALLER	1042-9
3	1	INSTRUCTION SHEET	1042-IS



### SURFACE TEMPERATURE INDICATING STRIPS

This product is an innovative tool that will alert you when you've reached 210 degrees. At this temp you should cease heating a main-shaft, flywheel sprocket shaft, motor, or transmission case to remove a stubborn bearing, studs, race, or gear. Just apply heat strip next to the race on the shaft your heating and watch the strip change color as you reach 210 degree. For more details see No. 899-IS for more details.

No. 899 - Heat temperature strips. Comes in a 30 piece heat strip pack.

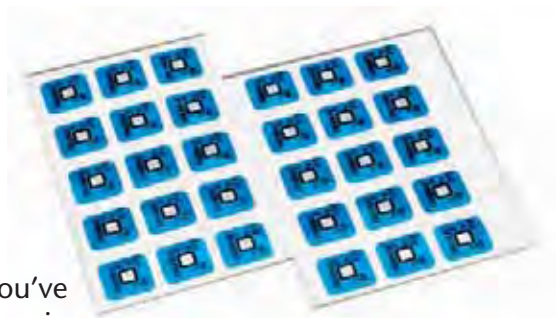



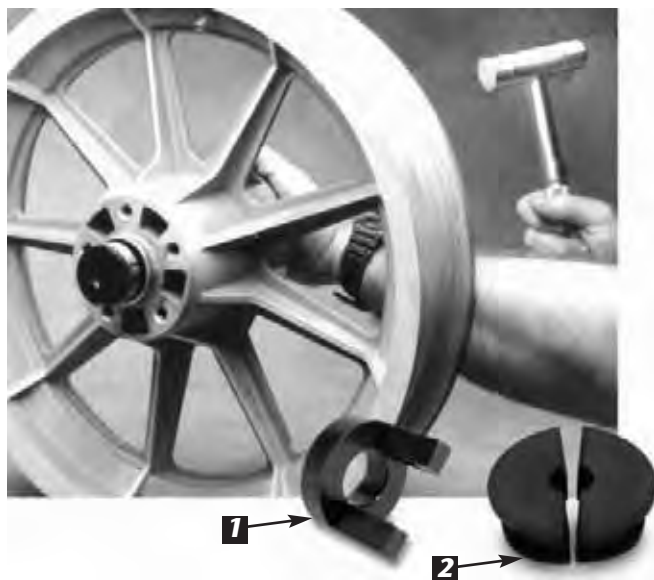

## WHEEL BEARING RACE REMOVER & INSTALLER TOOL

Use to remove and install bearing cups in cast wheels. Use with JIMS® handle No.33416-80, below and brass hammer, JIMS® No.1080. Comes with 1 spacer No.2388. *For more details see No.33071-IS instructions.*  
 No.33071-73 - Use on Big Twin and Sportster® 1973-99. Use on Buell® 1987-99.

### PARTS AVAILABLE SEPARATELY

NO.	QTY.	DESCRIPTION	PART NO.
1	1	SPACER	2388
2	1	RACE REMOVER HALF	33071-731
3	1	INSTRUCTION SHEET	2388-IS
4	1	INSTRUCTION SHEET	33071-IS



## REAR WHEEL COMPENSATOR BEARING REMOVER / INSTALLER TOOL

Use to remove and install the new compensator ball bearing, after the rear pulley is removed from the rear wheel drive bowl. This bearing is now positioned with the rubber isolators in the drive bowl. The tool will center and guide the installer plug with the center of the pulley for safe bearing installation. *For more details see No.947-IS instructions.*

No.947 - Use on all 2008 - present, V-Rod®, XL, & FL.

### PARTS AVAILABLE SEPARATELY

NO.	QTY.	DESCRIPTION	PART NO.
1	1	BASE	947-1
2	1	SLEEVE	947-2
3	1	DRIVER	947-3
4	1	INSTRUCTION SHEET	947-IS

## RACE & BEARING INSTALL TOOL HANDLE

Use with No's. 2232 above, 33071-73, 34810-84, 94547-80A & B, 97272-60 use on part No. 788 and 97273-60. Approximately 12" long. *For more details see No.33416-IS instructions.*

No.33416-80



### PARTS AVAILABLE SEPARATELY

NO.	QTY.	DESCRIPTION	PART NO.
1	1	O-RING	2310
2	1	INSTRUCTION SHEET	33416-IS

# LIFT CADDY & BIKE CENTER JACK



## JIMS LIFT CADDY

Introducing the patent pending "JIMS® Lift Caddy". This new unique product allows you to move your bike lift, with a bike on it, by yourself on a smooth floor. The sturdy steel design incorporates two low profile 2" wide heavy duty casters that can rotate 360 degrees, and is capable of handling today's heavy 900 lbs+ motorcycles. Even better, the Caddy is only activated when the lift is fully raised (not resting on any lock tabs). Once lowered to any lock tab, or the floor, the wheels camber up securing the lift to the floor as if the lift caddy isn't even there. In short, the lift only moves when you want it to and is secure when you are working on the motorcycle, as well as when loading and unloading. For more details see No.776-IS instructions.

No. 776 - "JIMS LIFT CADDY" will fit on "Handy®" lifts, "Handy's®" STANDARD No.10740,- and other lifts that incorporate a 2" wide cross member.

PARTS AVAILABLE SEPARATELY			
NO.	QTY.	DESCRIPTION	PART NO.
1	2	CASTER MOUNTS	776-1
2	1	FRAME MOUNT	776-2
3	1	STICKER (NOT SHOWN)	776-3
4	2	CASTER	2101
5	8	SCREW	2103
6	2	WASHER	2038
7	2	NUT	1027
8	1	INSTRUCTION SHEET	776-IS

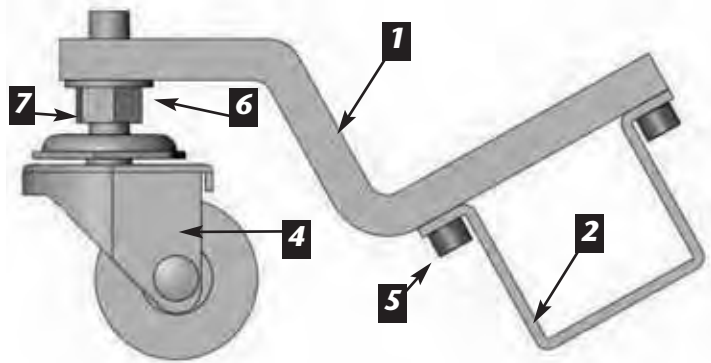

## BIKE CENTER JACK

This scissors type jack can lift either the front or rear of most motorcycles to perform wheel assembly service work. Order non-skid rubber pad separately for mounting to top of jack surface. Use with JIMS® alignment tool No.964.

No.904



## NON-SKID RUBBER PAD

Install this non-skid rubber pad to the top surface of JIMS® No.904 Bike Center Jack. Sold separately.

No.905

## TIRE ROTATOR TOOL

Use to rotate the front or rear tire. Have you ever wished you had a third hand? Well now you do.

Think about the possibilities of being able to put your motorcycle in high gear and turn the rear wheel with one hand and having the internal engine parts rotate. Check tappet adjustments, check cam timing, ignition timing, check primary chain adjustments, rear belt or chain adjustments, check spoke torque and install or remove any part or parts that need the engine rotated. Can also be used for finding the air fill and cleaning the wheel or tire. *For more details see No.936-IS instructions.*

No.936 - Use on all Big Twins, Sportsters, and Buells.

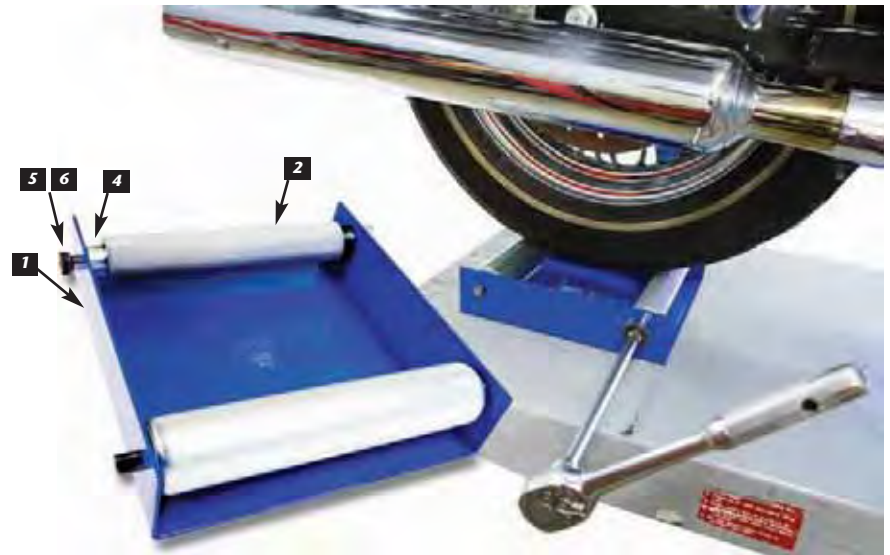

### PARTS AVAILABLE SEPARATELY

NO.	QTY	DESCRIPTION	PART NO.
1	1	SHEET METAL BASE	936-1
2	1	KNURLED ROLLER	936-2
3	1	SMOOTH ROLLER	936-3
4	1	SPACER WASHER	936-4
5	1	SHOULDER BOLT	2038
6	1	WASHER, 1/2"	2038
7	1	INSTRUCTION SHEET	936-IS

## WHEEL TRUING AND BALANCE STAND

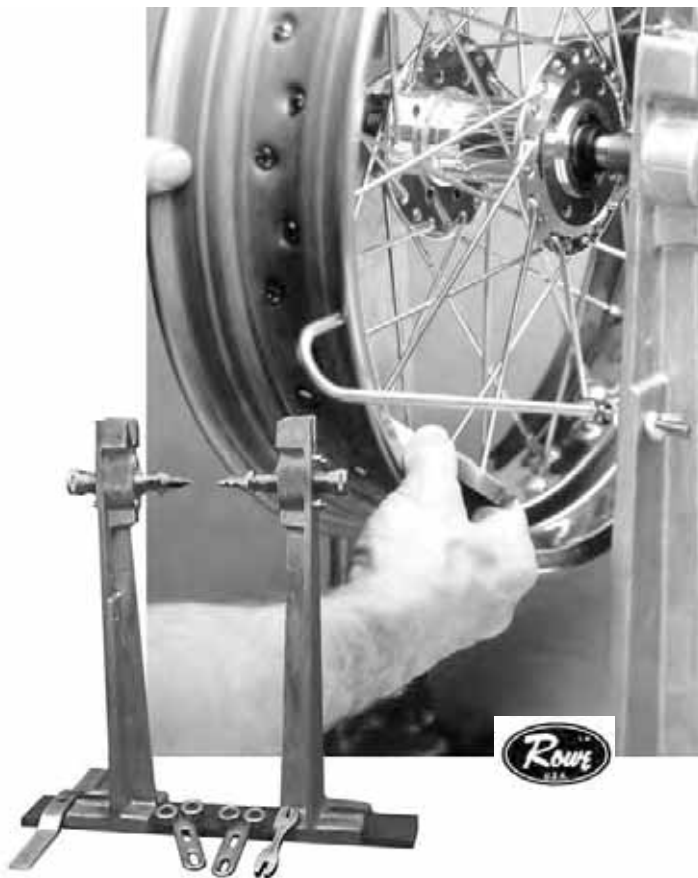

True on centers or on "V" slot. Balance on ball bearings. Made by Rowe®. This is the tool used in all the Harley-Davidson® Service Schools. Includes everything shown.

No.1069

## SPOKE WRENCH



This tool fits 6 nipple sizes. From 1 to 6. Made by Rowe®.

No.1059



**NEW**



## TIRE AIR PRESSURE GAUGE

The only thing between you and the road is your tires. The JIMS new rubber coated gauge, will give you accurate air pressure for any standard tire. Records pressure until release button is engaged.

No. 781 - Tire air pressure gauge.



## BRAKE BLEEDER KIT

Use this tool to catch brake fluid while bleeding the brake lines. The clear vinyl hose, and semi-transparent catch-can allows you to see when air is out of the line, and when the container is nearing full. Includes three bleeder fitting adapters.

No.1768 - Use on all hydraulic brakes.



## BRAKE CALIPER PISTON REMOVER

This tool will support the brake caliper pistons for removal by holding the pistons square to their bores. This prevents any damage to the pistons and the piston bores so seals & wipers can be replaced.

No.1162 - Use on all Big Twin, 4 piston brake calipers 2000-2007. Use on 2000 - 2003 XL.

No. 945 - Use on all new Hayes front brake calipers FXST and FXD 2008-present.

No. 946 - Use on all new Hayes rear brake calipers FXST and FXD 2008-present.

## WHEEL BEARING LOCKNUT SOCKET

Use to remove and install the slotted locknut to the correct torque on spoke wheels. For more details see No.94630-IS instructions.



No.94630-67 - Use on all Big Twin & Sportster® 1967-72.

### PARTS AVAILABLE SEPARATELY

NO.	QTY.	DESCRIPTION	PART NO.
1	1	CENTERING PIN	2202
2	1	INSTRUCTION SHEET	94630-IS



## HANDY PACKER™ BEARING PACKER

This tool is a quick and easy way to replace bearing grease in exposed ball or roller bearing bearings. Simply inject fresh grease through the grease fitting, set the bearing on the piston, and push down on the piston plunger. Includes easy-to-grip dust cover to keep stored grease like new. Works with bearings up to 3.5" O.D.

No.1766 - Use on all H-D® exposed ball or roller bearing bearings up to 3.5" O.D.



## UNIVERSAL BEARING PACKER

Simply place the bearing between the plastic cones, tighten, and apply grease through the fitting on the end of the threaded shaft. This tool forces out old grease and evenly injects fresh grease.

No.1767 - Use on all H-D® exposed ball or roller bearing bearings up to 4.125" O.D.

# MODULAR ENGINE & TRANSMISSION STANDS

## COMPLETE MODULAR ENGINE & TRANSMISSION STAND KIT (AS PICTURED)



This kit provides a solid and versatile work center for a variety of engine types. With this kit an engine builder can freely position complete engines and transmissions into the most optimum working position. The base stand allows 360° of rotation while the modular cradles swivel and lock in 180°, 90°, and 45° angles. The base easily bolts to a work bench, and comes ready to use with all hardware included. Each piece is constructed from high quality steel. For more details see No.1138-IS instructions.

### THIS KIT INCLUDES:

No.992 -	Twin Cam® Transmission Stand
No.1138 -	Base Stand
No.1139 -	"Taller" Single Cam Big Twin Cradle
No.1140 -	Twin Cam® "A" Cradle
No.1141 -	Sportster® and Buell® Cradle
No.1142 -	Twin Cam® "B" Engine Stand
No.1144 -	5 & 6 Speed Transmission

No.1145 - Complete Engine & Transmission Stand Kit. Use on all Twin Cam® "A" & "B", Big Twin, and Sportster® engine cases, and 5-Speed & 6-Speed transmissions.

## INDIVIDUAL "BASE, CRADLES, AND STANDS"

### BASE STAND

\* No.1138 - Use on all Twins, including Twin Cam 88" & 96" "A" & "B", Big Twin, Sportster® engines, and 5 & 6 speed transmissions.



### TALLER ENGINE CRADLE

\* No.1139 - Use on all 1936-00 Big Twins, EVO, Shovel, Pan, Knuckle & Flathead.

### SPORTSTER®/BUELL® ENGINE STAND

\* No.1141 - Use on all 1957-03 XL's and 1987-02 Buells®.



### ALL TWIN CAM® TRANSMISSION STAND

\* No.992 - Use on 1999 - present.



### TRANSMISSION STAND

\* No.1144 - Use on all 5 & after-market 6-Speed transmissions.



### TWIN CAM® BETA ENGINE STAND

\* No.1142 - Use on all "B" Twin Cam® 2000 - present.



### TWIN CAM® ALPHA ENGINE CRADLE

\* No.1140 - Use on all 1999 - present.



\*FOR MORE DETAILS SEE No.1138-IS INSTRUCTIONS.

# WORK BENCH STANDS



## 4 & 5-SPEED TRANSMISSION STAND

Use to clamp transmission in vice. Instruction sheet No.1008-IS. For more details see No.1008IS instructions.

No.1008-TU - Use on all Big Twin 4 & 5-Speed FXST 1984-present. When using stand for 5-Speed, use washers to space stand.



## TWIN CAM® BETA ENGINE STAND

This steel, powder coated stand uses special riser mounts to clear the rear balancer housing of the Beta style Twin Cam® case. For more details see No.902-IS instructions.

No.902 - Use on all Twin Cam®, Beta only, 2000 - Present.



## "TALLER" BIG TWIN ENGINE STAND

This powder coated finished stand is now 1-1/2" taller to fit all Big Twin cases for engine repair. New notch for crankcase breather fitting. For more details see No.1006-IS instructions.

No.1006T - Use on all Big Twins 1936-1999 single cam. (NOTE: Includes aftermarket motors.)



## TWIN CAM® ALPHA ENGINE STAND

This steel, powder coated stand is indispensable for all your engine Twin Cam® Alpha repairs. For more details see No.1022-IS instructions.

No.1022 - Use on all Twin Cam® Alpha only, 1999-Present.



## XL ENGINE STAND

Top-quality steel bench stand simplifies engine overhaul and has powder coated finish. For more details see No.1007-IS instructions.

No.1007 - Use on all Sportster® 1957-2003.  
Use on all Buell® 1987-2002.



## 5-SPEED TRANSMISSION STAND

For more details see No.1008-IS instructions.

No.1008-5 - Big Twin - Fits all rubber mount early 5-Speeds, non oil pan models cases.

### PARTS AVAILABLE SEPARATELY

QTY.	DESCRIPTION	PART NO.
1	BOLT	2034
1	NUT	2035
1	WASHER	2031
1	INSTRUCTION SHEET	1008-IS



# TWIN CAM ENGINE & TRANS PLUG KIT SADDLEBAG & TOUR PAK RIVET TOOL

 **NEW**

## TWIN CAM ENGINE AND TRANS PLUG KIT

This handy new kit is for engine and transmission rebuilders. This plug kit is for plugging the holes on all engine and trans when going through the steps of the rebuilding process. No longer do you need to hunt for rags for intake, plugs for speedo sensor or tappet bores, oil passages, spigot holes, etc... You name it, there's a plug for it. This is a solution for eliminating any destructive things from your assembly such as dirt, dust, misc. hardware, etc. Kit includes enough pieces for one twin cam engine and transmission, Alpha or Beta. *For more details see No.764-IS instructions.*  
No. 764 - Use on Any Twin Cam engine and transmission 1999 - present.



**PLUGS & CAP TYPES**



 **NEW**

**COMING SOON  
AFFORDABLE  
SOLUTION  
SIMILAR DESIGN**

## SADDLEBAG & TRUNK RIVET INSTALLER TOOL

This new more affordable JIMS hand tool is for used to install rivets used on the H-D OEM Fiberglass Saddlebags and Tour Paks latch mechanism pieces. Tool will fit H-D rivet No. 90965-63, or 90967-64. Note: Tool does not work on the bottom saddlebag spring clip with rivets H-D No. 90949-63. *For more details see instructions No.754-IS.*

No. 754 – Use on H-D Tour Packs 1964 to present and 1964 to 1994 Saddlebags.



**NOTE:** Wrench not included.

## ADJUSTABLE TORQUE WRENCH ADAPTER

Torque any fastener with a combination wrench or Allen wrench. This will work with 6mm (1/4") through 19mm (3/4") combination wrenches. Works with 6mm through 8mm Allen wrenches. This tool is heat-treated steel with black oxide finish. 3/8" square drive is rated for a maximum torque of 90 ft-lbs. Comes with instructions that include a conversion table.

No.922 - Adjustable torque wrench adapter.

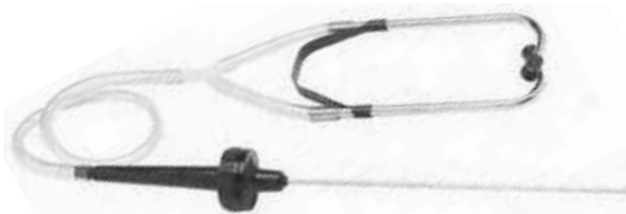

## MECHANIC'S STETHOSCOPE

This tool allows you to pinpoint internal engine noise by amplifying vibrations resonating through the metal probe. Simply touch the probe to the engine, and follow the noise to its loudest point.

No.1771



**INCLUDES  
RUBBER  
HOLDER**

## NINE (2-PIECE) SUPER TORX® BIT SET

This set of nine of the most popular Torx® keys are 20% stronger than one piece Torx® bits. Torx® keys are heat treated alloy steel. Includes six 1/4" drive, and three larger 3/8" drive bits.

No.1773 - Torx® Bit Sizes: T-10, T-15, T-20, T-25, T-27, T-30, T-40, T-45, T-50



## VICE SOFT JAWS

Aluminum covers for 3" to 5" bench vices. Saves wear and tear on your expensive parts from rough vice jaws. Made by Rowe®.

No.1057



## CLEATED ALUMINUM VICE SOFT JAWS

These soft jaws feature angular cleats ideal for holding round and hex parts. A Nitrile magnet holds the jaw pads to the vice. Measures 4" x 1-1/4"

No.1761



## RUBBER/ALUMINUM VICE SOFT JAWS

These soft jaws feature a rubber face good for holding odd shaped objects. A Nitrile magnet holds the jaw pads to the vice. Measures 4" x 1-1/4"

No.1762

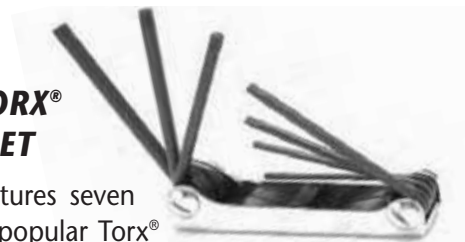

## 7-IN-1 TORX® KEY SET

This tool features seven of the most popular Torx® keys in a folding pocket size case. Torx® keys are heat treated alloy steel. Folded length is 4-1/4".

No.1772 - Torx® Key Sizes: T-10, T-15, T-20, T-25, T-27, T-30, T-40



## EXHAUST PIPE END SHAPER

Use this tool to remove exhaust pipe tip dents.  
No.1775 - Use on all models.

## SOLID BRASS PUNCH SET

Use this 3/8" punch for seating the check ball in oil pump. 4 piece set includes one each of:

- 3/8" x 6"
- 1/2" x 8"
- 5/8" x 9"
- 3/4" x 10"

No.1081



## DENTAL PICK

Not just for scraping tartar. This dental pick is a handy little tool for removing O-rings and burrs. This precision tool comes with a contoured grip for comfort, and is made from 24 series stainless steel, and hardened to 30-34 rockwell for durability. The fine tip end is hooked for easy usage, and proves to be useful in many aspects of motorcycle repair work.

No.2361 - Use to remove O-rings and burrs.



## THREAD CHASER TAP SET

This imported thread chaser set is an inexpensive way to clean up threads on frames or other parts that have been powdercoated or painted. Thread sizes are course, 1/4" -20, 5/16" -18, 3/8" -16, 7/16" -14, 1/2" -13, and 5/8" -12. Chasers are zinc plated and made from 1027 steel.

Note: Not for cutting new threads.

No.933 - Thread chaser set tap set.



## SOLID BRASS HAMMER

48oz. 1-1/4" head.

No.1080- Solid Brass Hammer.

## CABLE LUBER

This tool is used to inject lubricant into any mechanical cable housing. The tool clamps over your cable housing and inner cable allowing you to connect an aerosol lube can of cable lube to this luber tool. Spray until the lube runs out the other end of cable housing.

No.927 - Fits all O.E.M. or aftermarket mechanical clutch cables, and idle or throttle cables.







## SERVICE MANUALS FROM CLYMER

Commercial Motorcycle repair manuals provide step-by-step procedures based upon the complete disassembly of the motorcycle. This hands-on experience, combined with extensive research, results in a manual that is both detailed and user-friendly. Hundreds of original photos and illustrations guide the reader through every job, making it easy to reduce repair costs.

Whether it is routine maintenance, such as tune-ups and brake service or more extensive repairs involving engine and transmission disassembly, Clymer manuals provide reliable information required to perform the job. Accurate, clear and concise text, combined with detailed illustrations and photography, make it possible for the novice enthusiast to safely and enjoyably service their bike. While at the same time, those with more experience rely on the in-depth coverage for tackling more complicated procedures.



- No.514 - 2006 – 2011 Dyna™ Series
- No.513 - 2004 – 2009 FLH/FLT Touring Series
- No.512 - 2006 – 2009 Softail® Series
- No.500 - 2000 – 2005 Twin Cam Softail® Series
- No.501 - 1999 – 2005 FLH, FLT, Twin Cam® 88 & 103
- No.502 - 1999 – 2005 Twin Cam®, Dyna™
- No.503 - 1984 – 1999 EVO, Softail®
- No.504 - 1991 – 1998 EVO, Dyna™
- No.505 - 1984 – 1998 EVO, FLH, FLT, FXR
- No.506 - 1966 – 1984 Shovelheads
- No.507 - 1948 – 1965 Panhead
- No.508 - 2004 – 2005 EVO, Sportster®
- No.509 - 1991 – 2003 EVO, Sportster®
- No.510 - 1986 – 1990 EVO, Sportster®
- No.511 - 1959 – 1985 Ironhead, Sportster®



**JIMS AT THE RACE TRACK**

## PERMATEX ANTI-SEIZE LUBRICANT



This product is a refined blend of aluminum, copper, and graphite lubricants. Use for assembly to prevent galling, corrosion, and seizing. Helps prevent corrosion and is moisture resistant. Use for easy removal of spark plugs, head bolts, exhaust bolts, Etc. Temp. range - 60° to 1600°



No.4505 - 1oz. Squeeze tube.

No.4506 - 8oz. Brush top bottle.

## PERMATEX COPPER ANTI-SEIZE LUBRICANT



This premium quality anti-seize is a thread lube that prevents seizing, corrosion, and galling where high temperature conditions exist. Contains a high percentage of micro-fine copper flakes in a semi-synthetic grease carrier and is fortified with rust and corrosion inhibitors. Use on intake and exhaust hardware, oxygen sensors, head-bolts, etc. Heat range is -30° to 1800°



No.4507 - 8oz. Brush top bottle.



## PERMATEX MEDIUM OR HIGH STRENGTH GEL TWIST OR BOTTLE THREADLOCKER

Medium Strength Blue is a OEM specified all purpose threadlocker. Ideal for all nuts and bolts applications. Locks and seals while preventing parts loosening due to vibration. High Strength Red is a OEM specified and perfect for permanently locking cylinder studs, motor mount hardware, etc. Adds 3,000 PSI holding power on slip fit assemblies. Gel Twist Applicator: Medium Strength Blue Gel and High Strength Red Gel twist pin-point applicator puts the threadlocker where you want it on the part. This threadlocker gel provides the liquid quality without the problems. No drips, No globs, No waste.

No.4501 - 10g Medium Strength Blue Gel threadlocker twist applicator.

No.4502 - 10g High Strength Red Gel threadlocker twist applicator high.

No.4503 - 90mi Medium Strength Blue threadlocker bottle.

No.4504 - 90mi High Strength Red threadlocker bottle.



## PERMATEX ULTRA SLICK ENGINE ASSEMBLY LUBE

Proper lubrication of metal mating surfaces is essential prior to starting up a fresh rebuild. This ultra slick lube adheres to component parts to prevent scuffing or galling during initial start up. This slick lube meets or exceeds OEM specs. Perfect for use on cam lobes, bushings, valve guides, lifters, and rocker shafts, Etc.



No.4508 - 4oz Squeeze bottle.



## PERMATEX FAST ORANGE HAND CLEANER

This product was developed specifically for professional service technicians. Its noted for its dry skin formula that helps to reduce the symptoms of dry, cracked skin. The natural citrus formula has a unique polymeric skin conditioning system that leaves hands feeling smoother, while it quickly and gently deep cleans the toughest dirt. It also contains aloe, lanolin, glycerin, and other skin conditioners.



No.4509 - 1/2 gal Bottle with pump.



## PERMATEX SAFERSCRAPER PLASTIC SCRAPER

This is a safer alternative to razor blades. This is a specially designed hard plastic double-edged razor that is ideal for removing decals, bugs, tar, on windshields, fairings, sheet metal or bags without damaging the finish. Holder fits standard razor blades if job requires. Scraper comes with a five pack of refillable plastic blades.



No.4500 - Scraper and 5 refillable blades.



## PERMATEX NITRILE DISPOSABLE



### GLOVES

Nitrile gloves are made from 100% synthetic rubber that provides superior resistance to a wide range of solvents and hazardous chemicals. \*\* Nitrile gloves are suitable for users with natural rubber latex sensitivity. Gloves come with textured finger for easy pick up of small parts and are lightly powdered for ease of putting on or off.

No.4510 - Box of 100 Large Gloves.

No.4511 - Box of 100 Extra Large Gloves.

\*\* This product is not intended to protect against all chemical compounds.



## CLOVER® OIL BASED LAPPING COMPOUND

Clover® is the brand used by H-D® enthusiasts for years. Use on valves for a good seal, also used with all JIMS® lapping tools. Available in 2 grits – for roughing-in and finish work. Use on JIMS tool No. 96710-TL and 96740-36.

No.1083 - 16 oz Coarse 220 Grit (Micron finish of 32).

No.1084 - 16 oz Fine 320 Grit (Micron finish of 16).



## TORCO®/MPZ SPRAY LUBE PERFORMANCE LUBRICANTS

MPZ spray lube is a unique high-tech multi-purpose lubricant that stays put and will not let go. It leaves a heat resistant film that will not run, drip or evaporate off of treated metal surfaces. Designed as a pre-lube for engine assembly, valve springs, cam lobes, cam bearing etc.

Product Features: *Easy to use  
Spray Lube  
Heat Proof  
Wear Proof  
Will not  
Contaminate Oil  
Oil Soluble  
Non-Melting  
Rustproof  
Corrosion Proof  
Friction Proof  
Waterproof*



No.1226 - 10.8 Fl. Oz.

## TORCO® /MPZ ENGINE ASSEMBLY LUBE

MPZ engine assembly lube is petroleum base with two high molecular weight polymers to increase cohesive and adhesive strength. MPZ is added to provide maximum wear protection and low friction properties. Protects stressed engine parts from wear during initial new engine start up. A separate rust protection inhibitor is added to prevent rust while engines are in storage.

Product Features: *High Lubricity  
Friction Proof  
Rust Proof  
High Adhesion  
Will not contaminate oil  
Oil Soluble  
Non-Melting  
Rustproof  
Corrosion Proof  
Friction Proof  
Waterproof*



No.1228 - 4 Fl. Oz.

No.1229 - 12 Fl. Oz.



## TORCO® /MPZ CAM LUBE

MPZ cam lube is made from a non-melting gel and contains high molecular weight polymers that give it the adhesion strength necessary to stay in place on cam lobes, lifters and the highly stressed parts of the valve train. JIMS® recommends MPZ Cam Lube for wear protection during the initial cranking of a new or rebuilt engine.

Typical Uses: *Protects cam lobes, lifters, push rod ends, rocker shafts, etc.  
Assembly of seals*

Special Features: *Non-melting  
Will not Contaminate Oil, Oil Soluble  
No Moly Solids  
Will Not Allow Heat Build Up On Roller Bearings  
Will Slowly Wash Away as Motor Oil is Introduced Into The System*

No.1227 - 1 Fl. Oz.



## TAP MAGIC® TAP/CUTTING FLUID

This professional quality tapping fluid is specially formulated for use with all metals for improved surface finish, machinability, and tool life. Use with all JIMS® taps, drills, reamers, etc. And it's biodegradable!

No.1698 - 4 Fl. Oz.



## JIMS® BRAND T-SHIRTS - PIN-UP GIRL

Material is pre-shrunk 100% cotton.

### WHITE

- No.2161 - Medium
- No.2162 - Large
- No.2163 - X Large
- No.2164 - XX Large

### BLACK

- No.2165A - Medium
- No.2166A - Large
- No.2167A - X Large
- No.2168A - XX Large



## JIMS® BRAND T-SHIRTS - SKULLS

Material is pre-shrunk 100% cotton.

### GREY

- No.2552 - Medium
- No.2553 - Large
- No.2554 - X Large
- No.2555 - XX Large



## JIMS® BRAND T-SHIRTS - FLYWHEELS

Material is pre-shrunk 100% cotton.

### WHITE

- No.1106W - Medium
- No.1107W - Large
- No.1108W - X Large
- No.1109W - XX Large

### BLACK

- No.1106 - Medium
- No.1107 - Large
- No.1108 - X Large
- No.1109 - XX Large



## JIMS® BRAND T-SHIRTS - PISTONS

Material is pre-shrunk 100% cotton.

### BLACK

- No.2540 - Medium
- No.2541 - Large
- No.2542 - X Large
- No.2543 - XX Large







**JIMS® TRIBAL FLAME LOGO SWEATSHIRT**

**BLACK**

- No.2584 - Medium
- No.2585 - Large
- No.2586 - X Large
- No.2587 - XX Large



**JIMS® BRAND T-SHIRTS - TOOLS**

**BLACK**

- No.2556 - Medium
- No.2557 - Large
- No.2574 - X Large
- No.2579 - XX Large



**JIMS® TRIBAL FLAME LOGO T-SHIRT**

**WHITE**

- No.2544 - Medium
- No.2545 - Large
- No.2546 - X Large
- No.2547 - XX Large

**BLACK**

- No.2548 - Medium
- No.2549 - Large
- No.2550 - X Large
- No.2551 - XX Large



**JIMS® BRAND T-SHIRTS - 131"**

**BLUE**

- No.1238 - Medium
- No.1239 - Large
- No.1240 - X Large
- No.1241 - XX Large







**JIMS® LOGO DICKIES WORK SHIRT**  
NAVY BLUE

- No.2575 - Medium
- No.2576 - Large
- No.2577 - X Large
- No.2578 - XX Large



**JIMS® CHOPPER T-SHIRT**

Material is pre-shrunk 100% cotton.

**WHITE**

- No.2588 - Medium
- No.2589 - Large
- No.2590 - X Large
- No.2591 - XX Large

**BLACK**

- No.2592 - Medium
- No.2593 - Large
- No.2594 - X Large
- No.2595 - XX Large



**JIMS® BUY AMERICAN ZIPPER SWEATSHIRT**

**BLACK**

- No.2536 - Medium
- No.2537 - Large
- No.2538 - X Large
- No.2539 - XX Large



**BUY AMERICAN**



**JIMS® TWIN CAM® FLAME ENGINE HOODED SWEATSHIRT**

**GRAY**

- No.2558 - Medium
- No.2559 - Large
- No.2560 - X Large
- No.2561 - XX Large

# NUMERIC INDEX

0178-1010 .....	113	1041-TC .....	158	1106.....	226	1171.....	187
0178-1012.....	113	1044-TS.....	180	11067K.....	118	1171-1.....	187
0178-1033.....	113	1045RR.....	32	1106W .....	226	1171-2.....	187
1000-0001.....	12	1045-TS.....	180	1107.....	226	1171-3.....	187
1000-0002.....	12	1046.....	66	1107W .....	226	1172.....	162
1000-0003.....	12	1046-36A .....	89	1108.....	226	12013AK .....	126
1000-0010.....	13	1046P.....	66	1108W .....	226	12035AK .....	126
1000-0011.....	13	1047-TP.....	184	1109.....	226	1205.....	63
1000-0012.....	12	1048.....	184, 206	1109W .....	226	1208-1316.....	166
1000A.....	167	1050.....	204	1110.....	159	1208-3530.....	10
1001.....	146	1051.....	161	1111.....	159	1208-3535.....	10
1003.....	162	1052.....	187	11161.....	118	1226.....	225
1004A.....	193	1053.....	186	1130.....	193	1227.....	225
1005.....	202	1055.....	149	1133.....	38, 147	1228.....	225
1006T.....	218	1056.....	108	1134.....	IV	1229.....	225
1007.....	218	1057.....	220	1135.....	IV	1235.....	164
1008-5.....	218	1058.....	148	1136.....	IV	1236.....	165
1008-TS.....	218	1059.....	215	1138.....	217	1238.....	227
1010.....	161	1060.....	108	1139.....	217	1239.....	227
1011-36TB .....	157	1061.....	108	1140.....	217	1240.....	227
1012-70TB .....	157	1062.....	108	1141.....	217	1241.....	227
1013-54TB .....	159	1067.....	108	1142.....	217	1249.....	139
1014.....	200	1069.....	215	1144.....	217	1250.....	148
1015-37TB .....	159	1073.....	166	1145.....	217	1251.....	148
1016-37TB .....	159	1077.....	201	1146.....	177	1252.....	148
1017-37TB .....	157	1080.....	221	1147.....	143	1253.....	148
1018-37TB .....	159	1081.....	221	1148.....	161	1254.....	148
1019.....	108	1083.....	170, 224	1149.....	139	1255.....	165
1020.....	108	1084.....	170, 224	1150.....	38, 147	1256.....	165
1021.....	108	1087-2.....	138	1151.....	38, 147	1268K.....	125
1022.....	218	1090.....	132, 145	1152.....	38, 147	1269K.....	125
1023-70.....	153	1092C.....	61	1153.....	38, 147	1270K.....	125
1025-15.....	89	1092K.....	61	1154.....	38, 147	1271K.....	125
1029-53B .....	64	1093SP1K.....	44	1155.....	38, 147	1275.....	177
1029-53C .....	64	1093SP2K.....	44	1156.....	38, 147	1276.....	162
1029AP .....	65	1093SP3K.....	44	1158.....	161	1277.....	153
1029AP2 .....	65	1093SP4K.....	44	1159.....	139	1279.....	151
1029AP5 .....	65	1094.....	61	1160.....	33	1280.....	153
1029-TS.....	176	1094-C .....	61	1162.....	216	1281.....	177
1030-TS.....	176	1094-CK .....	61	1163.....	171	1283.....	154
1031-TS.....	176	1094-K .....	61	1164.....	163	1284.....	161
1032-TS.....	176	1095.....	60	1167.....	171	1285.....	154
1033-TS.....	176	1095C.....	60	1168.....	189	1286-1354.....	18
1034.....	173	1097.....	157, 159	1169.....	144	1286-1806.....	18
1035.....	108	11020K.....	118	1169-1.....	144	1288.....	178
1043.....	60	11057K.....	118	1170.....	206	1290.....	156

# NUMERIC INDEX

1300.....	42	1355K.....	41	1438.....	67	1608.....	29
1301.....	42	1356.....	42	1439.....	67	1608-3530.....	10
1302.....	43	1357.....	39	1440.....	67	1608-3535.....	10
1307.....	43	1358S.....	39	1441.....	67	1608A.....	29
1308.....	43	1359.....	42	1442.....	67	1608B.....	29
1308-1316.....	166	1360.....	42	1444.....	67	1611.....	18
1308-3530.....	9	1361.....	47	1457.....	27	1613.....	18
1308-3535.....	9	1361G.....	47	1491.....	18	1614.....	18
1309.....	42	1362.....	47	1493.....	18	1615.....	18
1310A.....	36	1362G.....	47	1501.....	18	1616.....	18
1310B.....	36	1363.....	47	1501B.....	18	1617.....	18
1311.....	36	1363G.....	47	1508-3530.....	9	1618.....	18
1312.....	36	1364.....	47	1508-3535.....	9	1620.....	29
1313.....	36	1364G.....	47	1519.....	18	1622.....	18
1313A.....	36	1368.....	43	1520.....	18	1623.....	18
1314.....	36	1369.....	43	1521.....	18	1624.....	18
1314S.....	36	1370.....	43	1522.....	18	1625.....	18
1315.....	36	1371.....	43	1523.....	18	1626.....	18
1315S.....	36	1372.....	43	1524.....	18	1627.....	18
1317.....	42	1373.....	43	1525.....	18	1628.....	18
1320.....	37	1374.....	43	1526.....	18	1629.....	18
1322.....	37	1375.....	43	1527.....	18	1658.....	203
1323.....	37	1376.....	43	1528.....	18	1664.....	203
1326.....	38	1377.....	42	1548.....	18	1665.....	185
1326-1.....	38	1383.....	40	1549.....	18	1666.....	185
1326-2.....	38	1384.....	40	1550.....	18	1667.....	193
1326-3.....	38	1385.....	40	1551.....	18	1672.....	177
1328.....	38	1390.....	156	1555.....	30	1674.....	193
1328-1.....	38	1400.....	169	1555A.....	30	1698.....	225
1328-2.....	38	1408.....	27, 168	1555B.....	30	1698E.....	91
1328-4.....	38	1408-3530.....	10	1558.....	30	1698EB.....	91
1340.....	39	1408-3535.....	10	1558A.....	30	1698L.....	91
1341.....	39	1409.....	27, 168	1558B.....	30	1698LB.....	91
1342.....	39	1410.....	155	1561.....	30	1699E.....	91
1342A.....	39	1411.....	155	1561A.....	30	1699EB.....	91
1343.....	39	1412.....	155	1561B.....	30	1699L.....	91
1344.....	39	1413.....	155	1576.....	30	1699LB.....	91
1346.....	39	1414.....	206	1576A.....	30	1700.....	204
1347.....	39	1417.....	173	1576B.....	30	1705.....	149
1348.....	39	1419.....	160	1584.....	30	1706.....	156
1349.....	42	1420.....	160	1584B.....	30	1707.....	208
1350K.....	41	1430.....	169	1602K.....	29	1708.....	121
1351K.....	41	1431.....	169	1603.....	18, 29	1708-3530.....	9
1352K.....	41	1432.....	169	1604K.....	29	1708-3535.....	9
1353K.....	41	1433.....	169	1607.....	29	1709.....	180
1354K.....	41	1437.....	67	1607B.....	29	1710.....	182



# NUMERIC INDEX

1711E.....	91	1771.....	220	1888.....	21	2162.....	226
1711EB.....	91	1772.....	220	1905.....	27	2163.....	226
1711L.....	91	1773.....	220	1908-3530.....	11	2164.....	226
1711LB.....	91	1774.....	148	1908-3535.....	11	2165A.....	226
1719.....	92	1775.....	206	1937.....	19	2166A.....	226
1720.....	198	1775.....	221	1938.....	19	2167A.....	226
1725.....	207	1777.....	206	1941.....	19	2168A.....	226
1726-1.....	161	1800.....	52, 54	1942.....	19	2169.....	126
1726-2.....	161	1800-2.....	52, 54	1943.....	19	2178K.....	34
1726-3.....	161	1800-5.....	52, 54	1944.....	19	2179K.....	34
1731.....	32	1803.....	52, 58	1945.....	19	2180K.....	34
1732.....	32	1807.....	51, 57	1946.....	19	2181K.....	120
1733.....	121	1808.....	51, 57	1957.....	20	2182K.....	120
17428-57K.....	34	1808-3530.....	11	1958.....	20	2183K.....	122
17428-83K.....	34	1808-3535.....	11	1959.....	20	2186K.....	83
17428-CCK.....	34	1809.....	51, 57	1960.....	20	2187K.....	83
17435-57B.....	33	1810.....	51, 57	1972.....	24	2188.....	152
1743.....	208	1811.....	51, 147	1973.....	24	2189.....	200
1744.....	92	1820.....	52, 58	1974.....	24	2196K.....	82
1745.....	182	1821.....	52, 58	1976.....	23	2197K.....	82
1746.....	XI	1822.....	52, 58	1977.....	23	2220.....	112
1747.....	XI	1827.....	II	1978.....	23	2201K.....	72
1748.....	XI	1828.....	II	1979.....	23	2201K.....	158
1752.....	90	1829.....	II	1980.....	23	2208-3530.....	8
1752B.....	90	18526-89SA.....	58	1981.....	23	2208-3535.....	8
1753.....	90	18526-89SA1.....	58	1982.....	23	2226.....	114
1753B.....	90	18526-89SA5.....	58	1983.....	23	2228.....	28
1754.....	90	18526-PG.....	57	1984.....	23	2229.....	28
1754B.....	90	18526-PG1.....	57	1985.....	23	2230.....	28
1755.....	90	18526-PG2.....	57	1986.....	23	2231.....	28
1755B.....	90	18526-PG5.....	57	1987.....	23	2232.....	207
1757.....	134, 142	18534-29A.....	59	2008-3530.....	10	2233.....	187
1758.....	134, 142	18534-CP.....	59	2008-3535.....	10	2234.....	189
1761.....	220	18554-57K.....	59	2043.....	205	2235.....	190
17611-66B.....	33	18555-36K.....	59	2044.....	205	2237.....	185
17611-83.....	33	18556-40K.....	59	2049.....	205	2239.....	70
17611-83H.....	33	18570-38K.....	59	2051.....	III	2239C.....	70
1762.....	220	18607-57A.....	63	2052.....	III	2239L.....	70
1763.....	142	18607-57AC.....	63	2053.....	III	2239LC.....	70
1764.....	142	18607-57AR.....	63	2054.....	III	2240.....	144
1765.....	165	1880.....	22	2108-3530.....	9	2240-11-4.....	144
1766.....	216	1881.....	21	2108-3535.....	9	2240-19.....	144
1767.....	216	1882.....	21	2121A.....	142	2243.....	157
1768.....	216	1883.....	21	2122A.....	142	2244.....	205
1769.....	188	1884.....	21	2144.....	166	2245.....	191
1770.....	142	1886.....	21	2161.....	226	2246.....	182

# NUMERIC INDEX

2249.....154	2370.....56	24003-55.....77	2430.....74
2250.....208	2371CH.....111	24005-37.....80	2431.....74
2251.....207	2371CK.....111	24005-57.....80	2427-1.....59
2256.....195	2371P.....111	24005-80.....80	2428-5.....65
2256-1.....181	2380.....45	24006-37.....80	2432.....74
2260.....194	2384.....119	24006-54A.....80	2433.....81
2262.....194	2385-7.....106	24006-58.....80	24331-36.....89
2280.....154	2386.....106	24006-73.....80	24334-36.....89
2281.....158	2386-7.....106	24006-80/83.....80	24335-36.....89
2283.....199	2388.....181	24006-83L.....80	2434.....81
2300.....68	23901-81.....77	24006-87.....80	2435.....92
2301.....XII, 68	23909-80.....79	24007-39.....80	2436.....92
2303.....69	2392.....148	24010-BLU.....84	24366-51K.....85
2305.....180	2394.....68, 111	24010-BR.....84	2437.....80
2311.....69	2395.....68, 111	24010-GR.....84	2438.....74
2312.....189	2396.....XII, 68, 111	24010-OR.....84	2439.....80
2315.....189	23960-29.....76	24010-RE.....84	2440.....85
2316.....189	23960-54.....76	24010-WH.....84	2442.....85
2317.....189	23960-80A3.....76	24010-YE.....84	2443.....85
2318.....189	23961-411.....75	24016-80.....77	2444.....85
2324.....181	23961-412.....75	24017-80.....77	2445.....85
2326B.....110	23961-413.....75	24020-51K.....82	2446.....85
2326CB.....110	23961-41S.....75	24022-90.....77	2447.....85
2327B.....110	23961-41ST3.....75	24023-36.....77	2448.....85
2327CB.....110	23961-80A2.....75	24023-36.....77	2449.....85
2336.....V	23961-80A3.....75	24023-54.....77	2450.....85
2337.....93	23961-80AS.....76	24029-KIT.....81	2451.....85
2337S.....93	23962-40.....75	2404.....46	2452.....85
2337ST.....93	23966-36.....77	24040-78.....84	2453.....85
2338.....93	23966-54A.....77	24041-78.....84	2454.....85
2338S.....93	23967-54A.....77	24042-78.....84	2455.....85
2340.....V	23969-83.....77	24043-78.....84	2456-1.....54, 57
2341.....145	23974-873.....75	24044-78.....84	2457-1.....54, 57
2344.....13	23975-873.....75	24045-78.....84	2458-1.....54, 57
2346.....196	2398.....XII, 68, 111	24046-78.....84	24585-39.....88
2347-7.....110	2400.....45, 55	2406.....63	24585-57.....88
2347-75C.....110	24000-29.....79	2411.....65	24587-39.....88
2347-7B.....110	24000-57.....79	2411C.....65	2459-1.....55
2347-7C.....110	24000-75.....79	2413.....70	24595-40.....88
2347-7CB.....110	24000-80.....79	2414.....70	24597-40.....88
2357.....150	24001-30.....79	2415.....81	24599-40.....88
2358K.....63, 125	24001-56.....79	2416.....45	24599-55.....88
2359K.....63, 125	24001-65.....79	2418.....62	24599-58.....88
2361.....221	24001-70.....79	2419.....62	24599-58A.....88
2362.....203	24001-72.....79	2428.....65	24599-58B.....88
2369.....46	24002-70.....81	2429.....74	24600-58.....88

# NUMERIC INDEX

24600-58A .....88	2512.....93	25588-57.....72	26346-36.....92
24600-58B .....88	2513.....93	25588-575.....72	26346-69/70.....92
2460-1.....55	25225-70BK .....125	2559.....228	26349-84.....92
24601-40.....88	25225-70BK .....125	25593-57.....73	26400-82.....92
24601-55.....88	25225-93K .....125	25593-74.....73	2808-3530.....11
24601-5810.....88	25225-93K .....125	25597-36.....72	2808-3535.....11
24601-5832.....88	25254-93A .....70	25597-365.....72	3000.....44, 68
24601-58A10 .....88	25258-80A .....70	2560.....228	3001.....44, 68
24601-58A32 .....88	2528.....120	2561.....228	3002.....44, 68
24601-58B10 .....88	2530.....109	2574.....227	3003.....44, 68
24601-58B32 .....88	2536.....228	2575.....228	3004.....44, 68
24610-39.....88	2537.....228	2576.....228	3005.....44, 68
2461-1.....55	2538.....228	2577.....228	3200.....164
24612-39.....88	2539.....228	2578.....228	3201.....164
2462-1.....56	2540.....226	25785-30A .....73	32591-70K .....125
24621-40.....88	2541.....226	2579.....227	33031-36.....108
24623-4032.....88	2542.....226	25791-36.....82	33031-76E.....108
24626-87.....87	2543.....226	25791-KIT .....82	33031-76L.....108
24628-87.....87	2544.....227	2584.....227	33031-80.....108
2463-1.....56	2545.....227	2585.....227	33071-73.....213
2464-1.....56	2546.....227	25856-36.....82	33096-54AL.....122
24641-87.....87	2547.....227	25856-KIT .....82	33096-54B .....122
24643-87.....87	2548.....227	2586.....227	33099-52A .....122
2465-1.....54, 58	2549.....227	2587.....227	33119-79A .....118
2466-1.....54, 58	2550.....227	2588.....228	33288-37.....122
2467-1.....54, 58	2551.....227	2589.....228	33288-375.....122
24703-54B .....81	2552.....226	2590.....228	33334-79.....117
2471-1.....58	2553.....226	2591.....228	33334-85.....117
2472-1.....58	2554.....226	2592.....228	33344-94.....117
2473-1.....58	2555.....226	2593.....228	33416-80.....152, 181,
2474-1.....56	2556.....227	2594.....228	.....207, 213
2475-1.....56	2557.....227	2595.....228	33428-78.....202
2476-1.....56	2558.....228	2607.....56	33438-501.....122
2480K.....83	25581-36.....72	2608.....56	33438-502.....122
2481K.....82	25581-70.....72	2608-3530.....8	33442-57A .....122
2482K.....82	25581-705.....72	2608-3535.....8	33442-73.....122
2483K.....83	25581-80AB .....72	2609.....56	33443-84.....160, 186
2488K.....83	25582-36.....73	2610.....56	33715-85AC .....119
2489K.....83	25582-365.....73	26207-83.....92	33902-98.....109
2505.....93	25582-54/73 .....73	2626-1.....59	33904-00.....109
2506.....93	25582-54/735 .....73	26262-80.....92	34088-87.....120
2507.....93	25582-80AB .....73	26315-68A .....92	34091-85.....116
2508.....93	25582-93.....73	26317-68A .....92	34140-36.....120
2509.....93	25582-935.....73	26326-62A .....92	34186-76.....120
2510.....93	25586-37.....72	26328-74.....92	34623-83.....163
2511.....93	25586-375.....72	26345-73.....92	34643-84.....146



# NUMERIC INDEX

34731-84.....146	38515-90.....192	5400.....I	705.....16
34734-80.....202	38515-91.....192	5401.....I	706.....16
34740-84.....146	39361-69.....183	5402.....I	707.....16
34761-84.....192	3998K.....89	5447.....I	720.....26
34782-91.....202	3999.....85	5457.....I, V	721.....26
34810-84.....201	4015.....22	5462.....I	725.....26
348-15.....76	4017.....22	6003K.....118	727K.....27
34902-84.....196	40250-94A.....121	6030.....60	729.....IX
34904-86K.....126	40250-94AK.....121	6031.....60	737.....X
35025-79B.....112	40520-63.....117	6032.....60, 68	738.....VIII
35026-79K.....117	41043.....76	6033.....XII, 60, 68	739.....IX
35039-80.....113	43067.....76	6035.....67	740.....VII
35042-79.....113	500.....222	6036.....67	741.....VII
35042-85.....113	5001.....121	6037.....67	742.....X
35042-91.....113	5001K.....121	6038.....69	742k.....X
35051-89.....115	501.....222	6039.....69	743.....X
35058-79K.....117	502.....222	604.....VIII	744.....X
35064-79K.....117	503.....222	6040.....69	74420-94.....119
35087-99K.....118	504.....222	6050.....69	74437-96.....119
35094-65.....117	505.....222	6051.....69	745.....X
35105-52.....116	506.....222	6052.....69	746.....X
35105-525.....116	507.....222	621.....109	747.....IX
35125-37.....116	508.....222	635.....94	750.....143
35125-3710.....116	509.....222	636.....94	751.....143
35125-372.....116	5100.....122	637.....94	7515K.....118
35125-375.....116	5101.....122	638.....94	752.....143
35211-91B.....121	5102.....122	639.....95	753.....176
35316-80.....198	5103.....122	640.....95	754.....XI
35322-38.....117	5104.....122	641.....95	755.....135
35614-65.....113	5105.....122	642.....95	756.....135
35614-76.....113	511.....222	643.....95	757.....VIII
35614-80.....113	512.....222	644.....95	758.....142
35622-79C.....112	513.....222	645.....95	759.....186
35625-79B.....112	514.....222	646.....95	761.....136
35626-79K.....117	5209.....15	647.....95	761.....136
35632-79.....113	5210.....15	648.....95	762.....136
35632S.....113	5215.....15	649.....95	763.....136
35652-79K.....126	5216.....15	650.....95	764.....219
35789-36.....117	5221.....15	651.....95	765.....131
35791-36.....117	5222.....15	652.....94	766.....131
35820-86.....203	5275.....17	653.....94	767.....195
35960-54.....114	5276.....17	700.....26	768.....195
35961-52.....114	5285.....17	701.....26	769.....162
36801-87K.....126	5286.....17	702.....26	770.....148
37047-91-5.....178	5287.....17	703.....26	771.....148
37047-91-6.....178	5288.....17	704.....16	772.....131

# NUMERIC INDEX

773.....	137	8045.....	113	8282.....	101	883.....	126
774.....	207	8046.....	113	8283.....	101	8876A.....	114
776.....	132	8047.....	113	8284.....	101	890.....	107, 126
776.....	214	8070.....	120	8291.....	112	8904.....	115
777.....	137	8085.....	105	8292.....	112	8905.....	114
778.....	141	8085L.....	105	8294.....	112	891.....	107, 126
779.....	172	8088.....	103	8296.....	112	892.....	107, 126
780.....	138	8096.....	109	8297.....	112	893.....	126
781.....	216	8096P.....	109	8298.....	112	8960.....	114
782.....	138	8100.....	106	8299.....	112	8961.....	114
783.....	136	8101.....	105	831.....	123	8977.....	115
784.....	135	8102.....	119	833.....	123	8978.....	115
785.....	175	8103.....	119	834.....	123	899.....	212
786.....	195	8111.....	102	835.....	123	8990K.....	71
787.....	152	8112.....	102	8360.....	119	8991K.....	71
788.....	149	8126.....	119	837.....	124	8992K.....	115
789.....	50	8131.....	107	8375.....	96	8996.....	115
789.....	147	8132.....	107	8376.....	96	8998K.....	115
7999.....	109	8133.....	107	8379.....	96	8999CK.....	111
7999B.....	109	8134.....	107	838.....	124	8999PK.....	111
7999P.....	109	8150.....	71	8380.....	97	900.....	197
800.....	126	816.....	126	8381.....	97	901.....	198
8000.....	102	817K.....	126	8382.....	96	902.....	218
8000C6.....	102	8235.....	99	8385.....	IV	9020.....	115
801.....	126	8236.....	99	8387.....	IV	904.....	214
8001.....	102	824.....	123	839.....	124	905.....	214
8001C6.....	102	8248.....	98	840.....	124	9057.....	71
802.....	126	8249.....	98	841.....	124	9058.....	71
8002.....	102	8250.....	98	842.....	124	906.....	209
8002C6.....	102	8251.....	98	843.....	124	908.....	149, 164
803.....	126	8252.....	98	844.....	124	908.....	164
8003.....	102	8253.....	98	851.....	125	9084.....	116
8003C6.....	102	8259.....	98	852.....	125	9084A.....	116
804.....	126	826.....	123	853.....	125	9085.....	116
8004.....	102	8260.....	98	854.....	125	9086.....	116
8004C6.....	102	8266.....	98	855.....	125	9095.....	116
8013.....	109	8267.....	98	857.....	26, 124	9096.....	116
8015.....	113	8269.....	107	858.....	26	9097.....	116
8016.....	113	827.....	123	859.....	26	910.....	165
8028.....	104	8273.....	101	870.....	26	911.....	199
8028C6.....	104	8274.....	101	871.....	26	9118.....	114
8030.....	104	8275.....	101	872.....	26	913.....	VI
8030C6.....	104	8277.....	107	873.....	26	915.....	172
8041K.....	119, 126	8279.....	101	873.....	124	9150A.....	86
8042K.....	119	828.....	123	881.....	126	9150AA.....	86
8044.....	113	8280.....	101	882.....	126	9152A.....	86

# NUMERIC INDEX

9154A.....	86	9418.....	86	95760-TP.....	159	993.....	151
9156A.....	86	942.....	140	95760-XL.....	151	994.....	154
9158A.....	86	9422.....	86	958.....	212	995.....	184
916.....	183	9423.....	86	959.....	27, 133	998.....	201
9160A.....	86	9424.....	86	95960-52C.....	193	D180.....	76
9161.....	86	9425.....	86	95970-32C.....	161		
917.....	44, 145	9426.....	86	960.....	172		
918.....	210	943.....	140	963.....	179		
9180.....	86	944.....	XI	96384-39.....	204		
9181.....	86	9441A.....	86	96385-78A.....	204		
9182.....	86	9441AA.....	86	964.....	210		
9183.....	86	9442A.....	86	965.....	95, 191		
9184.....	86	9443A.....	86	966.....	190		
9185.....	86	9444A.....	86	96600-36B.....	145		
9186A.....	86	9445A.....	86	967.....	190		
9186AA.....	86	9446A.....	86	96710-TL.....	170		
919.....	210	945.....	216	96740-36.....	162		
9198K.....	71	9450A.....	86	96780-32A.....	163		
920.....	207	94547-80A.....	181	96780-58A.....	163		
921.....	211	94547-80B.....	181	96781-72.....	163		
922.....	220	94555-55A.....	185	968.....	189		
9220AA.....	87	94557-55A.....	189	96830-51.....	185		
9221A.....	87	946.....	216	969.....	135		
9222A.....	87	94630-67.....	216	970.....	209		
9223A.....	87	94660-37A.....	194	97081-54.....	178		
9224A.....	87	947.....	213	971.....	97, 191		
9225A.....	87	948.....	146	97178-71.....	192		
923.....	211	94804-57.....	150	972.....	195		
924.....	211	94805-57.....	170	97225-55.....	178		
925.....	211	949.....	146	97235-55B.....	183		
926.....	211	950.....	209	97272-60.....	152		
927.....	221	951.....	166	97273-60.....	152		
928.....	209	952.....	172	973.....	179		
930.....	166	953.....	138	974.....	174		
931.....	166	954.....	141	975.....	174		
932.....	166	955.....	134	976.....	174		
933.....	221	95560-57.....	200	977.....	205		
934.....	188	95660-42.....	196	981.....	197		
935.....	188	95660-77.....	196	984.....	199		
936.....	215	95660-85.....	196	985.....	203		
937.....	146	956.....	133	986.....	202		
938.....	146	956K.....	133	987.....	197		
939.....	VI, 212	957.....	171	988.....	40, 145		
940.....	175	95724-57.....	160	989.....	194		
941.....	188	95760-57.....	150	990.....	153		
9417.....	86	95760-TB.....	151	992.....	217		



## **DISCLAIMER**

The words Harley®, Harley-Davidson® and H-D® and all H-D® part numbers and model designations are used in reference only. JIMS® is in no way associated with or authorized by Harley-Davidson® Motor Co. to manufacture and sell any of the engine parts described in this catalog. The installation of JIMS® parts may void or otherwise adversely affect your factory warranty. It is the sole and exclusive responsibility of the user to determine the suitability of the product for his or her use, and the user shall assume all legal, personal injury risk and liability and all other obligations, duties and risks associated therewith.

## **RETAIL SALES**

As a JIMS® Distributor or Dealer you are assured that we will not sell directly to retail customers, and our products will only be available through independently owned and operated legitimate motorcycle businesses (licensed commercial places of business serving the general public primarily in the area of motorcycle sales, service, and/or parts and accessories). Retail customers in possession of this catalog will be able to use it for reference only.

## **SALES**

JIMS® parts are obtainable from many shops and dealerships throughout the world. If an individual does not have access to one of our dealers, please contact us. In order to receive dealer prices, new customers must provide proof of bonafide motorcycle business operation in the form of a photo copy of Sellers Permit, business letterhead and/or business card, photograph of storefront and 3 (three) trade/credit references, within the motorcycle industry.

## **TERMS**

Dealers - We gladly accept any size order, however, a service charge of \$10.00 will be added to orders under \$100.00. All orders will be sent C.O.D., certified check / money order, Visa® or MasterCard® in the continental USA. Company checks will be accepted from dealers whose financial histories warrant it. Any orders from outside the USA must be prepaid in US funds via wire transfer, a transfer fee will apply, or by Visa® or MasterCard®, a handling fee will apply to all credit card transactions. A \$10.00 service charge will be applied to all drop-ship requests.

## **PRICES**

The prices for all JIMS® parts are F.O.B. Camarillo, CA. We reserve the right to change prices and/or discounts without notice and to bill at the prevailing prices at the time of shipment. Please check invoice for changes.

## **ORDERING**

Our goal is to handle your order as quickly and efficiently as possible. To help us do this you will be assigned a dealer representative. Please have your customer number, full purchaser's name, part numbers, and quantities ready when you call. Orders may also be placed in writing or via fax. Special order forms are not necessary. Please include, a phone number where you can be reached during business hours, a shipping address and shipping preference: UPS - Red (1 day), Blue (2 day), Orange (3 day), or Ground. If no preference is indicated, order will be sent UPS ground.

## **BACKORDERS**

JIMS® makes an ongoing effort to improve parts availability, however, backorders cannot always be avoided. Items not in stock at the time of order will be placed on backorder. Once parts are available the customer will be notified (only once) by phone for authorization to ship. Order will be canceled if authorization is not received within one week. The customer shall assume responsibility of notifying JIMS® if the parts are no longer needed. Invoice will show the items that have been backordered.

## **REFUSED SHIPMENTS**

Orders that are refused or returned to JIMS® for reasons such as "lack of cash on hand" or "no one available to receive shipment", etc. are subject to a 20% restocking fee. Additionally, the customer is liable for all shipping charges. Any restocking fees and shipping charges that total \$50.00 or more must be paid before any future business transactions are made. Charges less than \$50.00 will be added to the customer's next purchase. After two refused shipments, all future orders will be released only after prepayment of invoice total. A pattern of refused orders may result in termination of customer account.

## **SHIPPING**

Prompt service and accurate orders are our primary consideration. Orders are normally processed and shipped the same day received, provided they are received before 2:00 p.m. Pacific Standard Time.

JIMS® ships by United Parcel Service in the continental USA. Overseas customers - Due to the high shipping and customs cost, it is suggested that overseas customers supply a shipping carrier for all large orders. All others, unless otherwise specified, will be shipped by UPS Express (3-4 day service) or UPS Expedited (5-6 day service). All orders will be shipped prepaid.

## **RETURNS**

All items are carefully packaged and in good condition when shipped. Please inspect product immediately upon receipt of shipment. JIMS® must be notified within 5 (five) working days of the receipt of a shipment of any shortages or incorrect shipments. It is advisable to phone JIMS® as problems can often times be corrected more quickly with a direct call. Any claims for damages must be made with the carrier and not with JIMS®. Please be sure to save all boxes and packaging material when filing a claim and keep them until settlement is made.

### **QUALITY IS NO PROTECTION AGAINST ABUSE, MISUSE OR NEGLECT.**

The following qualifications are necessary to receive credit, or to exchange merchandise.

1. Call JIMS® before shipping parts back to obtain an RGA number.
2. The parts must be returned within 10 days of receipt.
3. They must be packaged properly to prevent any damage during shipping. Damaged parts due to poor packaging are non-returnable and will be returned to the owner at the owner's expense. Repackaged goods using JIMS® containers does not always mean the items are packaged properly.
4. All returns must be sent to JIMS® insured and prepaid. No CODs will be accepted.
5. All returns must be accompanied by the return goods authorization number, a copy of the original invoice of purchase and a note explaining the reason for the return.
6. Under no circumstances are damaged, altered, rusty, or otherwise unusable parts returnable. Upon acceptance of the returned parts by JIMS® under the above criteria, a 20% restocking fee will be charged.
7. Acceptance of returned goods by our Receiving Department shall not be binding and has no force or effect unless acceptance is made by us in writing.





## **WARRANTY**

All JIMS® parts are guaranteed to the original purchaser to be free of manufacturing defects in materials and workmanship for a period of 6 (six) months from the date of purchase, unless otherwise noted. Merchandise that fails to conform to these conditions will be repaired or replaced at JIMS® option if the parts are returned to us by the purchaser within the 6 (six) month warranty period or within 10 (ten) days thereafter. In the event warranty service is required, the original purchaser must call or write JIMS® immediately with the problem. Some problems can be rectified by a telephone call and need no further course of action. A part suspected of being defective must not be replaced by a Dealer without prior authorization from JIMS®. If it is deemed necessary for JIMS® to make an evaluation to determine whether the part is defective, it must be packaged properly to prevent further damage and be returned prepaid to JIMS® with a copy of the original invoice of purchase and a detailed letter outlining the nature of the problem, how the part was used and the circumstances at the time of failure. If after an evaluation has been made by JIMS® and the part was found to be defective, repair, replacement or credit will be granted.

## **ADDITIONAL WARRANTY PROVISIONS**

1. JIMS® shall have no obligation in the event a JIMS® part is modified by any other person or organization.
2. JIMS® shall have no obligation if a JIMS® part becomes defective in whole or in part as a result of improper installation, improper maintenance, improper use, abnormal operation, or any other misuse or mistreatment of the part.
3. JIMS® shall not be liable for any consequential or incidental damages resulting from the failure of a JIMS® part, the breach of any warranties, the failure to deliver, delay in delivery, delivery in nonconforming condition, or for any other breach of contract or duty between JIMS® and a customer.
4. JIMS® parts are designed exclusively for use in Harley-Davidson® motorcycles. JIMS® shall have no warranty or liability obligation if a JIMS® part is used in any other application.
5. Any parts which have been replaced for any reason become the property of JIMS®, and will not be returned under any circumstances.







wheeliepig



panhead\_jim



red\_ranger\_dyna



slydogcycles

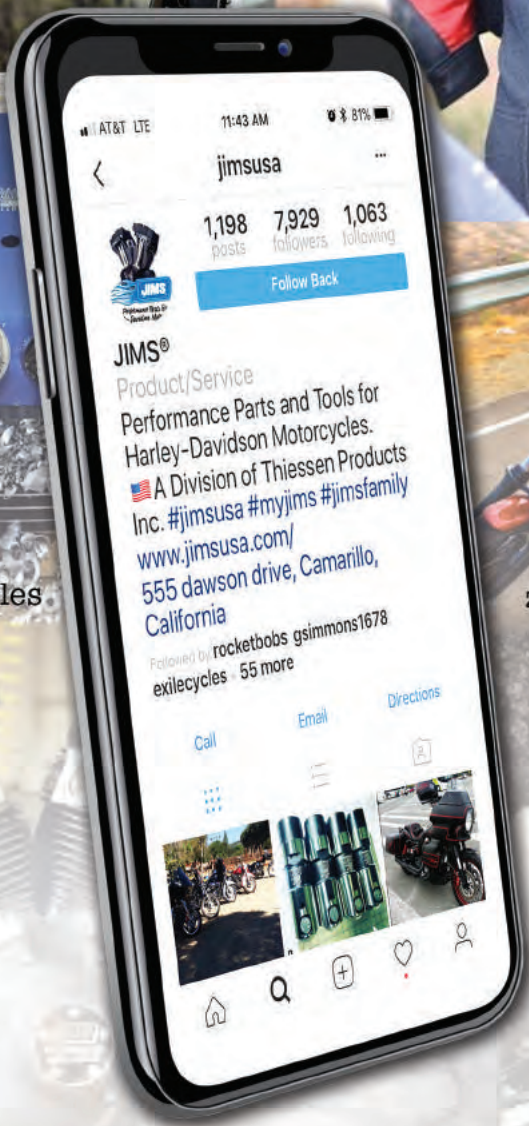

hirokoisoracing



z.wiley



ratbike\_service

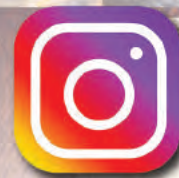

Be a part of the JIMS family.  
Share with the JIMS family.  
#MyJIMS on Instagram



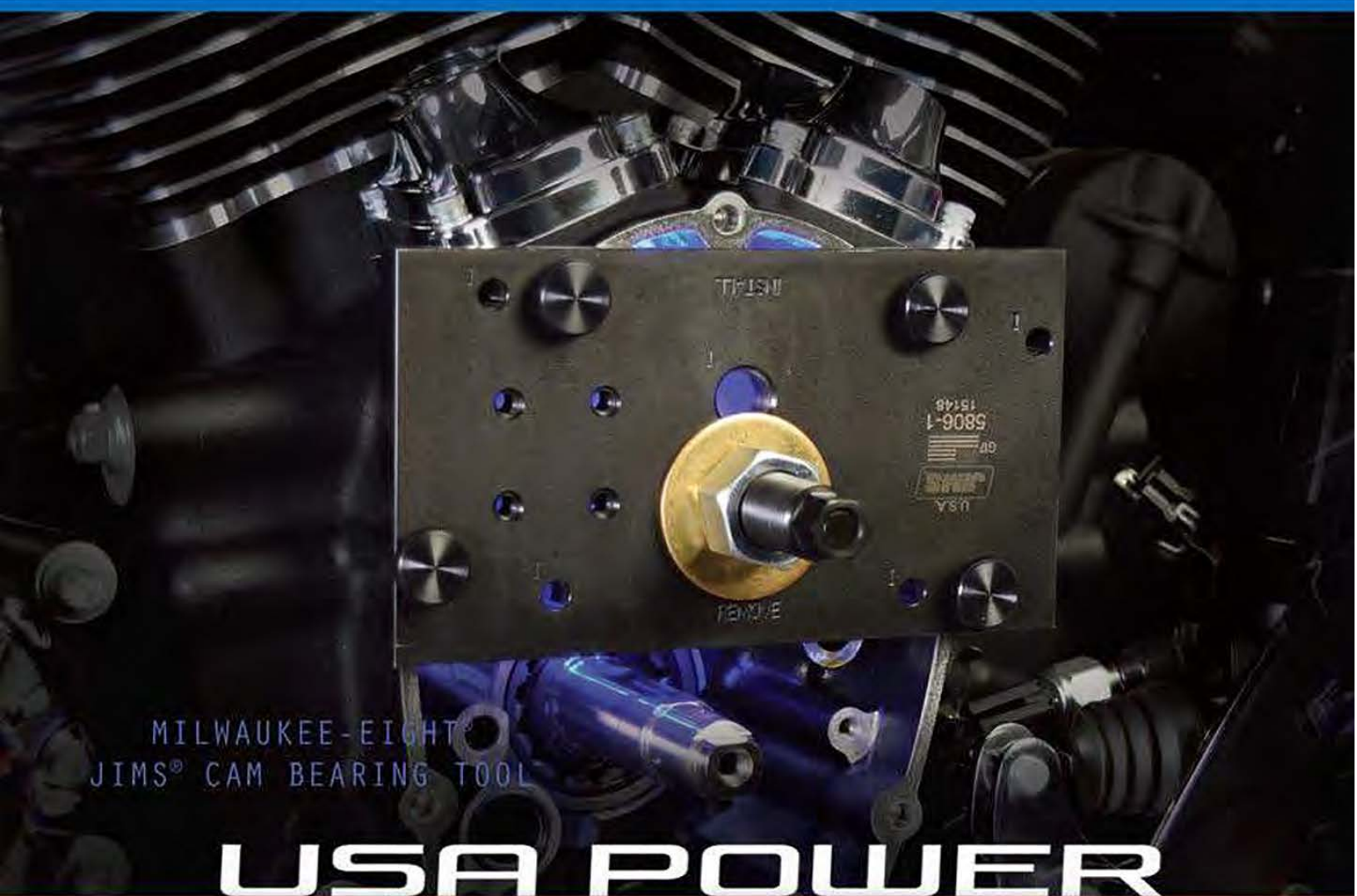

MILWAUKEE-EIGHT  
JIMS® CAM BEARING TOOL

**USA POWER**

